

Snorkel TM12

Operator Manual

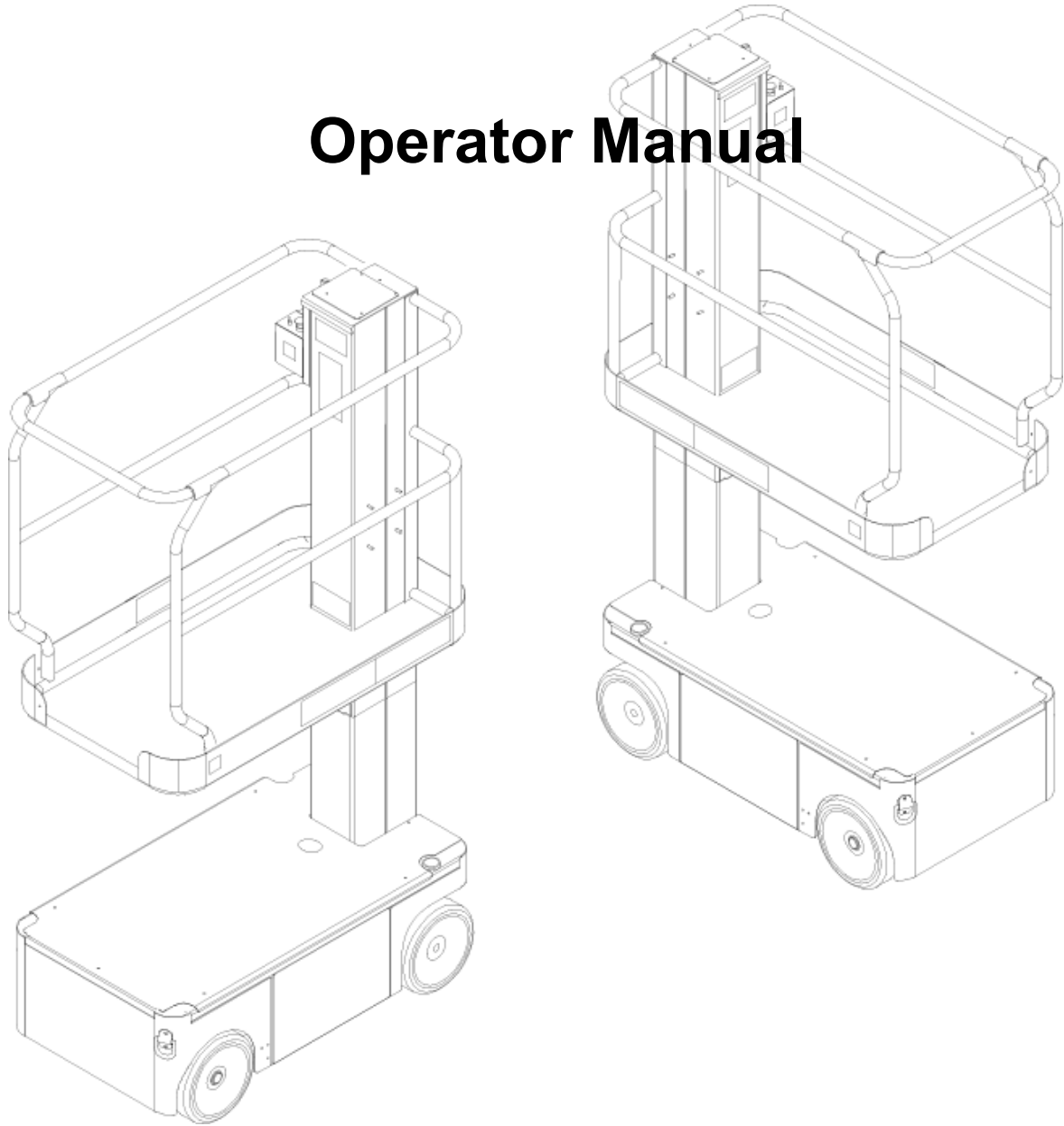

TM 12

ENGLISH

When contacting Snorkel for service or parts information, be sure to include the MODEL and SERIAL NUMBERS from the equipment nameplate. Should the nameplate be missing, the SERIAL NUMBER is also stamped on top of the chassis above the front axle pivot.

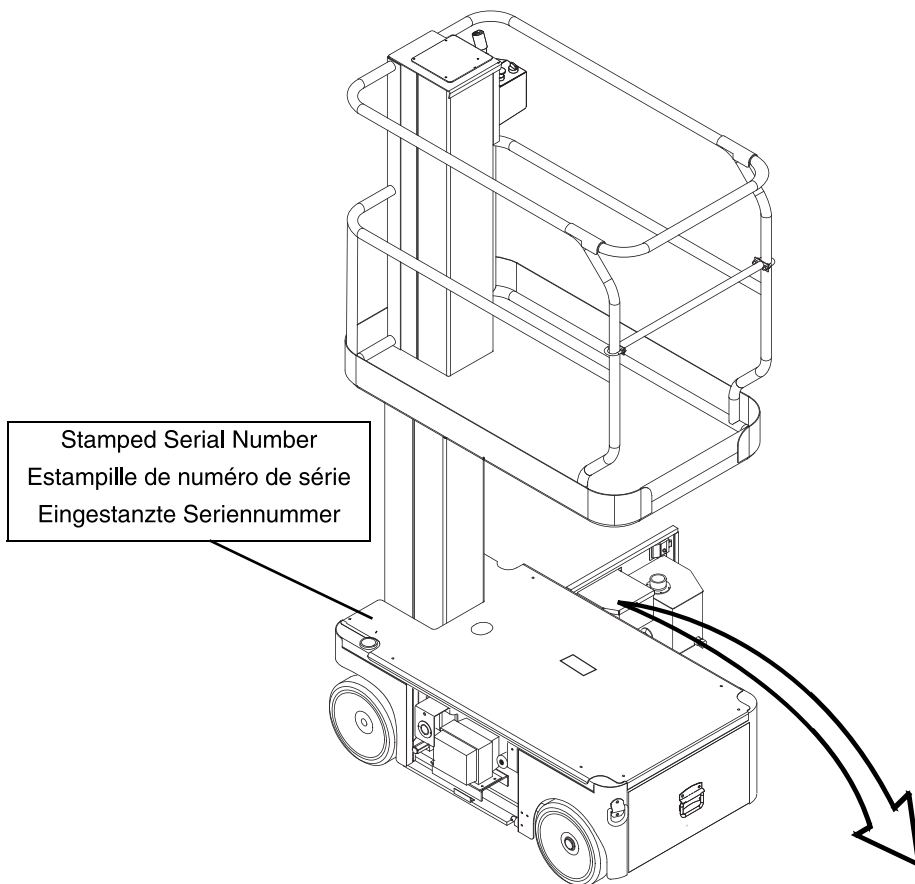

Snorkel		CE	VIGO CENTRE, WASHINGTON, TYNE & WEAR, UK
MODEL NUMBER	TM12	SERIAL NUMBER	
MONTH/YEAR OF MANUFACTURE		SLOPE SENSOR ALARM SETTING	2°
MAXIMUM MACHINE WEIGHT	1720lbs 780kg	MAXIMUM WHEEL LOAD	430lbs 182kg
DRIVE MOTORS	24V	BATTERIES	24V 220Ah
MAXIMUM ALLOWABLE MANUAL FORCE (SIDE PULL)	90 lbs Indoor 45 lbs Outdoor	RATED NUMBER OF OCCUPANTS	2 Persons Indoor 1 Person Outdoor
MAXIMUM PLATFORM HEIGHT	12ft 3.73m	PLATFORM SIZE	29x41in 74x104cm
MAXIMUM ALLOWABLE WIND SPEED	28mph 12.5m/s	MAXIMUM DRIVE HEIGHT	12ft 3.73m
		UNRESTRICTED PLATFORM CAPACITY	500lbs 227kg
CAUTION		THIS MACHINE IS MANUFACTURED TO COMPLY WITH ANSI A92.5 - 1992	
DO NOT REMOVE ANY WEIGHT FROM THIS MACHINE. ANY WEIGHT ADDED MUST BE DISTRIBUTED EQUALLY ON EACH AXLE. PROPER STABILITY AND AXLE WEIGHTS OF THIS MACHINE ARE BASED ON THE PLATFORM SIZE SHOWN ABOVE.			
AXLE WEIGHTS WITH MACHINE IN STOWED - TRAVEL POSITION			
STEER AXLE	860lbs 390kg	DRIVE AXLE	860lbs 390kg
			505049-002

Snorkel

www.snorkelusa.com

2. OPERATION MANUAL

WARNING

All personnel shall carefully read, understand and follow all safety rules and operating instructions before operating or performing maintenance on any UpRight Powered Access aerial work platform.

Safety Rules

Electrocution Hazard

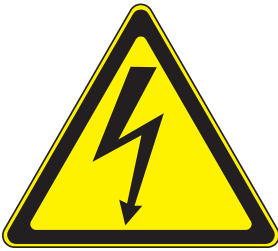

THIS MACHINE IS NOT INSULATED!

Tip Over Hazard

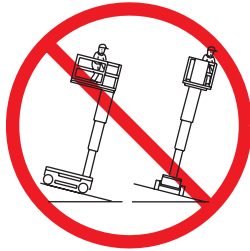

NEVER elevate the platform or drive the machine while elevated unless the machine is on a firm, level surface.

Collision Hazard



NEVER position the platform without first checking for overhead obstructions or other hazards.

Fall Hazard

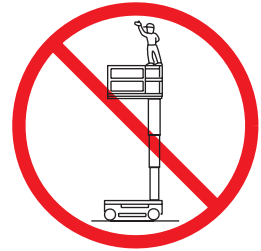

NEVER climb, stand, or sit on platform guardrails or midrail.

USE OF THE AERIAL WORK PLATFORM: This aerial work platform is intended to lift persons and his tools as well as the material used for the job. It is designed for repair and assembly jobs and assignments at overhead workplaces (ceilings, cranes, roof structures, buildings etc.). All other uses of the aerial work platform are prohibited!

THIS AERIAL WORK PLATFORM IS NOT INSULATED! For this reason it is imperative to keep a safe distance from live parts of electrical equipment!

Exceeding the specified permissible maximum load **is prohibited!** See "Platform Capacity" on page 4 for details.

The use and operation of the aerial work platform as a lifting tool or a crane **is prohibited!**

NEVER exceed the manual force allowed for this machine. See "Manual Force" on page 4 for details.

DISTRIBUTE all platform loads evenly on the platform.

NEVER operate the machine without first surveying the work area for surface hazards such as holes, drop-offs, bumps, curbs, or debris; and avoiding them.

OPERATE machine only on surfaces capable of supporting wheel loads.

NEVER operate the machine when wind speeds exceed this machine's wind rating. See "Beaufort Scale" on page 4 for details.

IN CASE OF EMERGENCY push EMERGENCY STOP switch to deactivate all powered functions.

IF ALARM SOUNDS while platform is elevated, STOP, carefully lower platform. Move machine to a firm, level surface.

Climbing up the railing of the platform, standing on or stepping from the platform onto buildings, steel or prefab concrete structures, etc., **is prohibited!**

Dismantling the entry gate or other railing components **is prohibited!** Always make certain that the entry gate is closed and securely locked!

It is prohibited to keep the entry gate in an open position when the platform is raised!

To extend the height or the range by placing of ladders, scaffolds or similar devices on the platform **is prohibited!**

NEVER perform service on machine while platform is elevated without blocking elevating assembly.

INSPECT the machine thoroughly for cracked welds, loose or missing hardware, hydraulic leaks, loose wire connections, and damaged cables or hoses before using.

VERIFY that all labels are in place and legible before using.

NEVER use a machine that is damaged, not functioning properly, or has damaged or missing labels.

To bypass any safety equipment **is prohibited** and presents a danger for the persons on the aerial work platform and in its working range.

NEVER charge batteries near sparks or open flame. Charging batteries emit explosive hydrogen gas.

Modifications to the aerial work platform **are prohibited** or permissible only at the approval by **UpRight Powered Access**.

AFTER USE, secure the work platform from unauthorized use by turning the keyswitch off and removing key.

CONTENTS

Introduction	3
General Description	3
Special Limitations	4
Platform Capacity	4
Manual Force	4
Beaufort Scale	4
Controls and Indicators	5
Pre-Operation Safety Inspection	5
System Function Inspection	6
Operation	7
Travel With Platform Lowered	7
Steering	7
Elevating Platform	7
Travel With Platform Elevated	7
Lowering Platform	7
Emergency Lowering	8
Parking Brake Release	8
After Use Each Day	8
Transporting the Machine	9
By Crane	9
By Forklift	9
By Truck	9
Maintenance	10
Blocking the Elevating Assembly	10
Installation	10
Removal	10
Hydraulic Fluid	10
Check Hydraulic Fluid	10
Battery Maintenance	11
Battery Charging	11
Inspection and Maintenance Schedule	12
Daily Preventative Maintenance Checklist	13
Specifications	14

INTRODUCTION

This manual covers all models of the TM12 Aerial Work Platform. This manual must be stored on the machine at all times.

Read, understand and follow all safety rules and operating instructions before attempting to operate the machine.

GENERAL DESCRIPTION

1. Platform

⚠ WARNING ⚠

DO NOT use the maintenance platform without guardrails properly assembled and in place

2. Entry Bar

3. Elevating Mast

4. Platform Controls

5. Manual Case

6. Electrical Box

7. Hydraulic Reservoir

8. Level Sensor (inside Door)

9. Battery Tray

10. Emergency Lowering Valve

11. Battery Charger

12. Drive Relief Valve

13. Charger Outlet Plug

Figure 1: TM12 Series

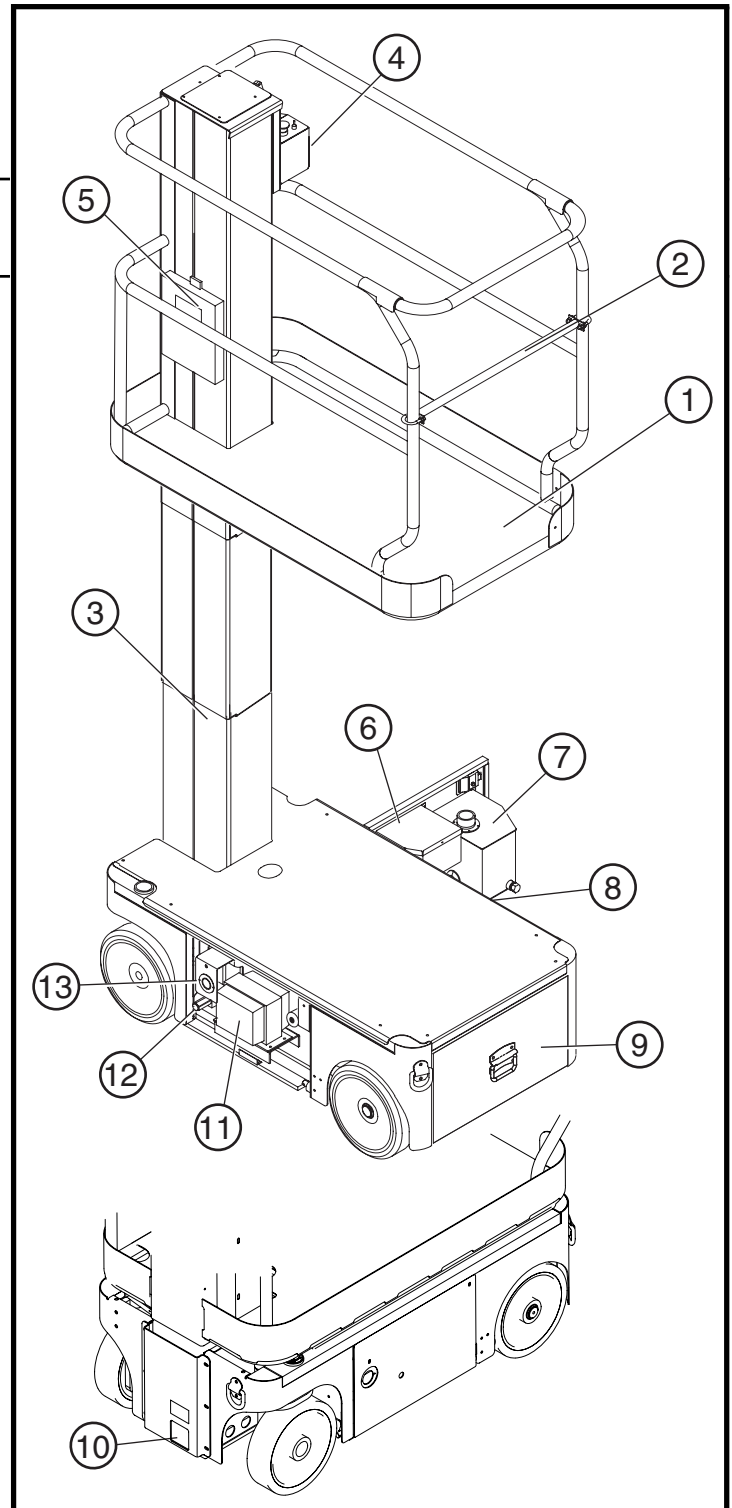

SPECIAL LIMITATIONS

Travel with the platform raised is limited to creep speed range.

Elevating the platform is limited to firm, level surfaces only.



The elevating function shall ONLY be used when the work platform is level and on a firm surface.

The work platform is NOT intended to be driven over uneven, rough, or soft terrain.

PLATFORM CAPACITY

The maximum platform capacity for the TM12 is 227 kg (500 lbs). Two people may occupy the platform indoors, while only one may occupy the platform outdoors.



DO NOT exceed the maximum platform capacity or the platform occupancy limits for this machine.

MANUAL FORCE

Manual force is the force applied by the occupants to objects such as walls or other structures outside the work platform.

The maximum allowable manual force is limited to 200 N (45 lbs.) of force per occupant, with a maximum of 400 N (90 lbs.) for two occupants.



DO NOT exceed the maximum amount of manual force for this machine.

BEAUFORT SCALE

Never operate the machine when wind speeds exceed 12.5m/s (28mph) [Beaufort scale 6].

BEAUFORT RATING	WIND SPEED				GROUND CONDITIONS
	m/s	km/h	ft/s	mph	
3	3,4~5,4	12,25~19,4	11.5~17.75	7.5~12.0	Papers and thin branches move, flags wave.
4	5,4~8,0	19,4~28,8	17.75~26.25	12.0~18	Dust is raised, paper whirls up, and small branches sway.
5	8,0~10,8	28,8~38,9	26.25~35.5	18~24.25	Shrubs with leaves start swaying. Wave crests are apparent in ponds or swamps.
6	10,8~13,9	38,9~50,0	35.5~45.5	24.5~31	Tree branches move. Power lines whistle. It is difficult to open an umbrella.
7	13,9~17,2	50,0~61,9	45.5~56.5	31.-38.5	Whole trees sway. It is difficult to walk against the wind.

CONTROLS AND INDICATORS

The operator shall know the location of each control and indicator and have a thorough knowledge of the function and operation of each before attempting to operate the unit.

Figure 2: Controls and Indicators

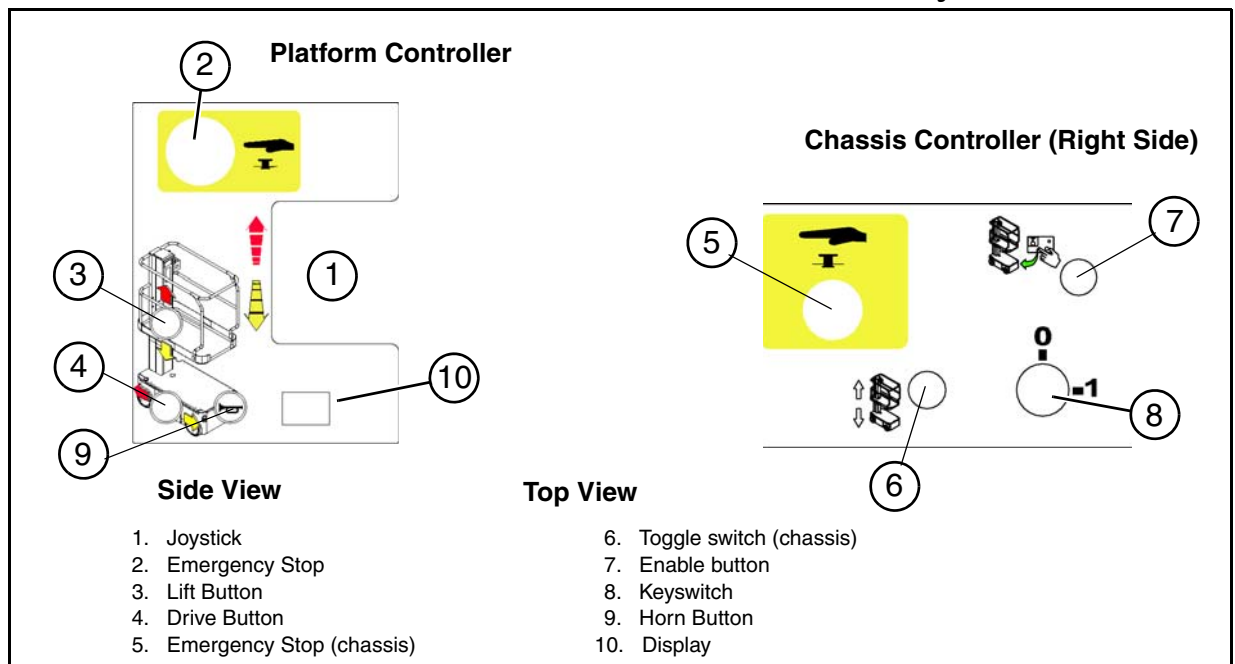

PRE-OPERATION SAFETY INSPECTION

NOTE: Carefully read, understand and follow all safety rules, operating instructions, labels and National Safety Instructions/Requirements. Perform the following steps each day before use.

1. Open the Chassis Door and inspect for damage, fluid leaks or missing parts.
2. Check the level of the hydraulic fluid with the platform fully lowered. Open the Chassis Door and remove the reservoir cap, fluid should be visible on the dipstick. Add recommended hydraulic fluid if necessary. See "Specifications" on page 14.
3. Check that the fluid level in the batteries is correct. See "Battery Maintenance" on page 11.
4. Verify that the batteries are charged.
5. Check that the A.C. extension cord has been disconnected from the chassis outlet.
6. Check that all guardrails are in place and all fasteners are properly tightened.
7. Inspect the machine thoroughly for cracked welds and structural damage, loose or missing hardware, hydraulic leaks, damaged control cable and loose wire connections.

SYSTEM FUNCTION INSPECTION

Refer to Figure 1 and Figure 2 for the locations of various controls and indicators.

⚠ WARNING ⚠

STAND CLEAR of the work platform while performing the following checks.

Before operating the machine, survey the work area for surface hazards such as holes, drop-offs, bumps and debris.

Check in **ALL** directions, including above the work platform, for obstructions and electrical conductors.

Protect the control console cable from possible damage while performing checks.

1. Move the machine, if necessary, to an unobstructed area to allow for full elevation.
2. Turn the Chassis and Platform Emergency Stop Switches ON by pulling the buttons out.
3. Turn the Chassis Key Switch to ON.
4. Push the Chassis Lift Switch to the UP position and fully elevate the platform.
5. Visually inspect the mast assembly for damage or erratic operation. Check for missing or loose parts.
6. Verify that the depression mechanism supports have rotated into position under the machine.
7. Check Level Sensor operation:
 - a. Open the door.
 - b. Position the machine off of level.
 - c. Push the Chassis Lift Switch to the UP position.
 - The alarm should sound, and the platform should not lift more than 500mm.
 - d. Close and latch the door.
8. Partially lower the platform by pushing the Chassis Lift Switch to DOWN, and check the operation of the audible lowering alarm.
9. Check the Chassis Emergency Lowering Valve for proper operation (see Figure 4):
 - a. Open the valve by pulling the knob out.
 - b. Once the platform is fully lowered, close the valve by releasing the knob.
10. Push the Chassis Emergency Stop Switch down to the OFF position. All machine functions should be disabled. Pull out the Chassis Emergency Stop Switch to resume.
11. Mount the platform.
12. Check that the route is clear of persons, obstructions, holes and drop-offs, is level and capable of supporting the wheel loads.
13. After mounting platform, lower the bar across the entrance.
14. Select DRIVE mode.
15. While depressing the Interlock Switch, slowly position the Control Lever to FORWARD then REVERSE to check for speed and directional control. The farther you push or pull the Control Lever from center the faster the machine will travel.
16. Push the Steering Switch RIGHT then LEFT to check for steering control.
17. Push the Platform Emergency Stop Switch down to the OFF position. All machine functions should be disabled. Pull out the Platform Emergency Stop Switch to resume.

Figure 3: Level Sensor Location

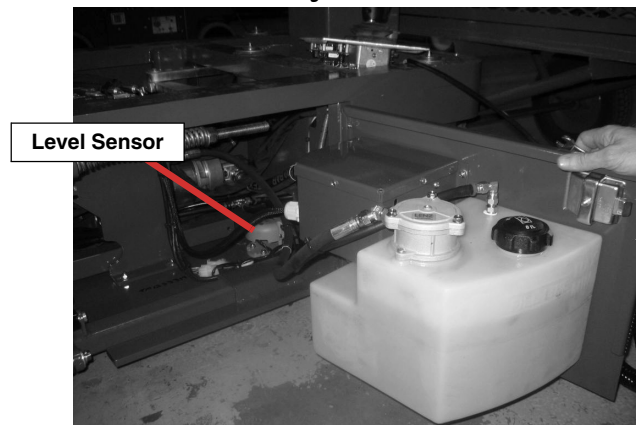

OPERATION

Before operating the machine, ensure that the Pre-Operation Safety Inspection has been completed and that any deficiencies have been corrected. **Never operate a damaged or malfunctioning machine.** The operator must be thoroughly trained on this machine.

TRAVEL WITH PLATFORM LOWERED

1. Check that the route is clear of people, obstructions, holes and drop-offs, is level and is capable of supporting wheel loads.
2. Verify that the Chassis Key Switch is turned to ON and the Chassis Emergency Stop Switch is ON, (pull button out).
3. After mounting the platform, lower the bar across entrance.
4. Check clearances above, below and to the sides of the machine.
5. Pull the Controller Emergency Stop switch up to the ON position.
6. Select DRIVE mode.
7. While depressing the Interlock Switch, slowly push or pull the Control Lever to FORWARD or REVERSE position to travel in the desired direction. The farther you push or pull the Control Lever from center the faster the machine will travel.

STEERING

NOTE: Steering is not self-centering. Wheels must be returned to straight ahead position by operating the Steering Switch.

1. Select DRIVE mode.
2. While depressing the Interlock Switch, push the Steering Switch to RIGHT or LEFT to turn the wheels in the desired direction. Observe the tires while maneuvering the machine to ensure proper direction.

ELEVATING PLATFORM

1. Select LIFT mode.
2. While depressing the Interlock Switch, push Control Lever forward to UP, the farther you push the Control Lever the faster the Platform will elevate.
3. If the machine is not level the Tilt Alarm will sound and the machine will not lift or drive. If the Tilt alarm sounds the platform must be lowered and the machine moved to a level location before attempting to re-elevate the Platform.

TRAVEL WITH PLATFORM ELEVATED

NOTE: The machine will travel at reduced speed when the platform is elevated.

1. Check that the route is clear of persons, obstructions, holes and drop-offs, is level and capable of supporting the wheel loads.
2. Check clearances above, below and to the sides of the platform.
3. Select DRIVE mode.
4. While depressing the Interlock Switch, push Control Lever to FORWARD or REVERSE for desired direction of travel.
5. If the machine is not level the Tilt Alarm will sound and the machine will not lift or drive. If the Tilt alarm sounds the platform must be lowered and the machine moved to a level location before attempting to re-elevate the Platform.

LOWERING PLATFORM

1. Select LIFT mode.
2. While depressing the Interlock Switch, pull back on the Control Lever.

EMERGENCY LOWERING

⚠ WARNING ⚠

If the platform should fail to lower, NEVER climb down the elevating assembly.

Stand clear of the elevating assembly while operating the Emergency Lowering Valve Knob.

Ask a person on the ground to open the Emergency Lowering Valve to lower the platform. The Emergency Lowering Valve is located at the front of the chassis.

1. Open the Emergency Lowering Valve by pulling the knob out.
2. To close, release the knob.

NOTE: The platform will not elevate if the Emergency Lowering Valve is open.

Figure 4: Emergency Lowering Valve

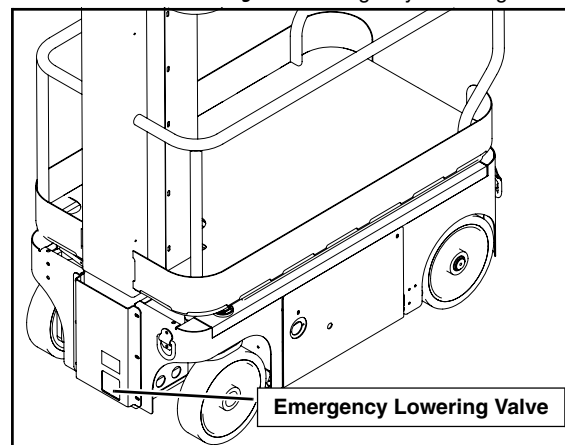

PARKING BRAKE RELEASE

Perform the following procedure only when the machine will not operate under its own power and it is necessary to move the machine, or when winching onto a trailer to transport.

1. Remove the spring compression nut so the spring is loose and the brake bars are away from the tires.
2. The machine will now roll when pushed or pulled.

After moving the machine and before normal operation:

1. Replace the spring compression nut and tighten until the spring measures 22,2-22,9 cm (8¾"-9") in length, verify that the brake bars have fully engaged the tires before the machine is operated.

Figure 5: Parking Brake Release

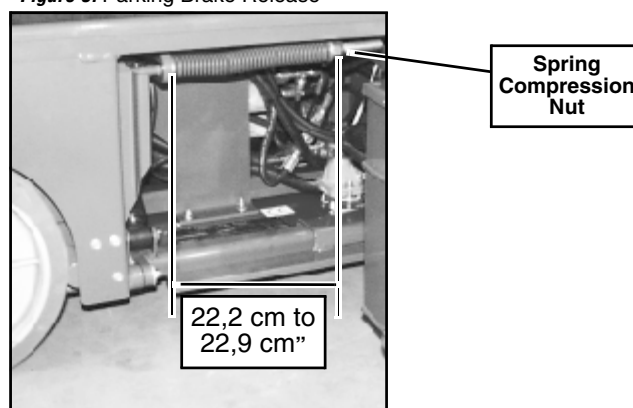

⚠ WARNING ⚠

Never tow faster than 0,3 m/sec. (1 ft./sec.).

Never operate the machine with the parking brakes released. Serious injury or damage could result.

AFTER USE EACH DAY

1. Ensure that the platform is fully lowered.
2. Park the machine on a firm level surface, preferably under cover, secure against vandals, children and unauthorized operation.
3. Turn the Chassis Key Switch to OFF and remove the key to prevent unauthorized operation.

TRANSPORTING THE MACHINE

BY CRANE

Secure the straps to chassis lifting/tie down points only.

BY FORKLIFT

⚠ DANGER ⚠

Forklifting is for transport only.

See specifications for weight of machine and be certain that forklift is of adequate capacity to lift the machine.

Forklift from the side by lifting under the Chassis.

BY TRUCK

1. Maneuver the machine into transport position and chock wheels.
2. Secure the machine to the transport vehicle with chains or straps of adequate load capacity attached to the chassis lifting/tie down points.

CAUTION

Overtightening of the chains or straps attached to the Tie Down lugs may result in damage to the machine

Figure 6: Transporting the Machine

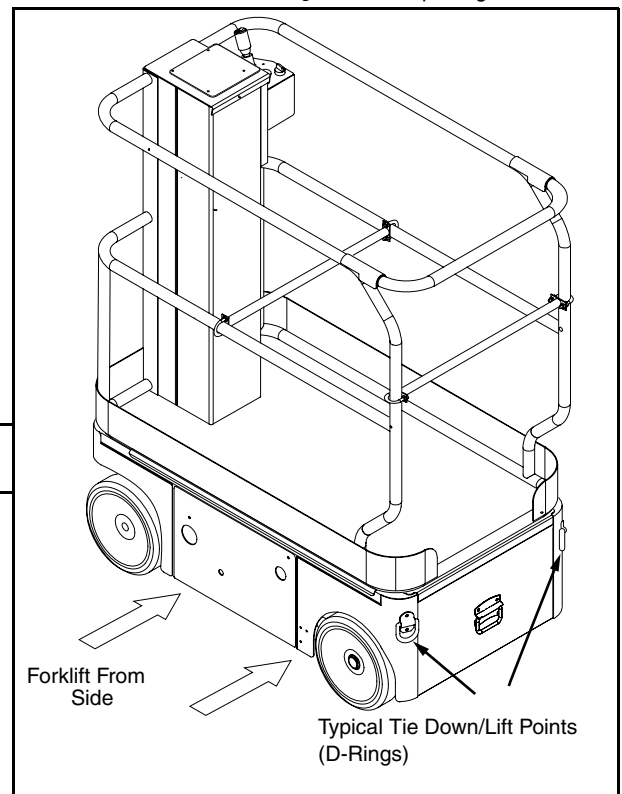

HOURLY METER

To access the hour meter function perform the following steps.

1. Climb into the basket (with the machine powered up)
2. Push the platform emergency stop button.
3. Hold down the following buttons, Horn and Lift.
4. While holding the buttons twist the emergency stop button to return power to the machine.
5. "hr" will now be displayed on the readout, Pressing the right turn button will scroll through the accumulated hours two digits at a time. For example, if pressing the right turn button once displays "20", pressing it a 2nd time displays "58", and pressing it a 3rd time displays "hr", the elapsed time of operation is 2058 hours.

MAINTENANCE

⚠ WARNING ⚠

Never perform service while the platform is elevated without first blocking the elevating assembly.
DO NOT stand in the elevating assembly area while deploying or storing the brace.

BLOCKING THE ELEVATING ASSEMBLY

INSTALLATION

1. Park the machine on firm level ground.
2. Verify that both Emergency Stop Switches are ON.
3. Turn and hold the Chassis Key Switch to CHASSIS.
4. Position the Chassis Lift Switch to UP and elevate the platform approximately 1,2 m (4 ft.).
5. Place a solid wood block, 51mm x 100mm x 45cm (2"x 4"x18") between the second mast section and Chassis just behind the mast assembly.
6. Push the Chassis Lift Switch to the DOWN position and gradually lower the platform until the second mast section is supported by the block.

Figure 7: Supporting the Elevating Assembly

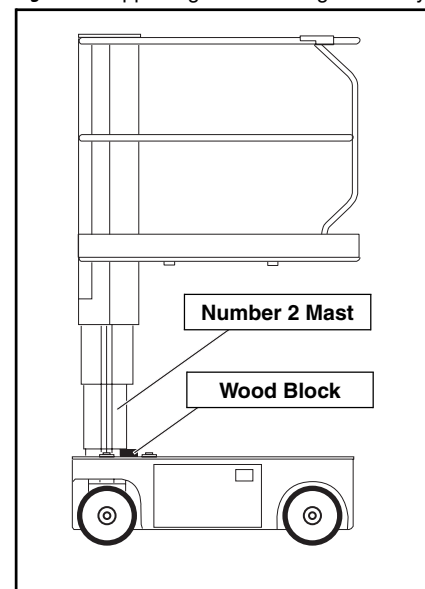

REMOVAL

1. Push the Chassis Lift Switch to the UP position and gradually raise platform until the wood block can be removed.
2. Remove the block.
3. Push the Chassis Lift Switch to the DOWN position and completely lower the platform.

HYDRAULIC FLUID

The hydraulic fluid reservoir is located in the chassis door.

NOTE: Never add fluid if the platform is elevated.

CHECK HYDRAULIC FLUID

1. Make sure that the platform is fully lowered.
2. Open the chassis door.
3. Check the fluid level using the guage on the tank.
4. To add Hydraulic fluid remove Filler Cap in Fig 8.
5. Add the appropriate fluid to bring the level to the FULL mark. See "Specifications" on page 14

Figure 8: Hydraulic Fluid Reservoir and Dipstick

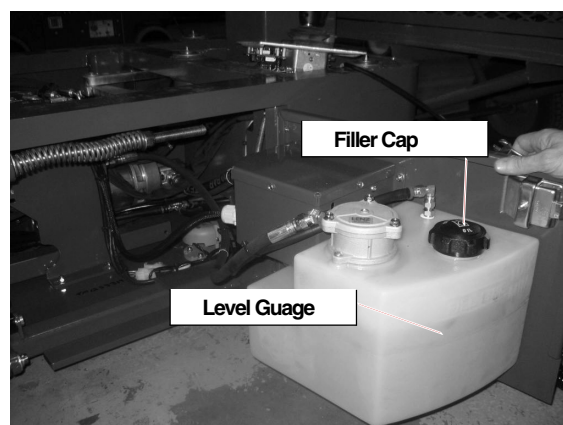

BATTERY MAINTENANCE

Figure 9: Access to Batteries

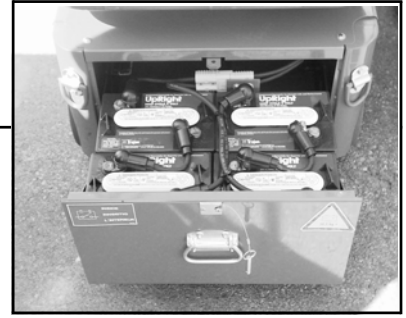

WARNING

Hazard of explosive gas mixture. Keep sparks, flame, and smoking material away from batteries.

Always wear safety glasses when working near batteries.

Battery fluid is highly corrosive. Thoroughly rinse away any spilled fluid with clean water.

Always replace batteries with UpRight batteries or manufacturer approved replacements weighing 26,3 kg (58 lbs.) each.

- Check the battery fluid level daily, especially if the machine is being used in a warm, dry climate.
- Keep the terminals and tops of the batteries clean.
- Refer to the Service Manual to extend battery life and for complete service instructions.

BATTERY CHARGING

Figure 10: Battery Charge Indicator

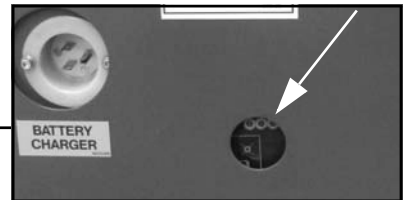

WARNING

Charge the batteries in a well ventilated area.

Do not charge the batteries when the machine is near a source of sparks or flames.

Permanent damage to the batteries will result if the batteries are not immediately recharged after discharging.

Never leave the battery charger operating for more than two days.

Never disconnect the cables from the batteries when the charger is operating.

Keep the charger dry.

1. Check the battery fluid level. If the battery fluid level is lower than 10 mm ($\frac{3}{8}$ in.) above the plates add distilled water only.
2. Connect an extension cord (1,5 mm² [12 gauge] minimum conductor diameter; 15 m (50 ft.) maximum length) to the charger plug located at the left side of the chassis.
3. The charger turns on automatically after a short delay. Look through the charge indicator cutout to check the state of charge.
 - 0 - 50% charge:
 - First Light -BLINKING-
 - Second and Third Light -OFF-
 - 50% - 75% Charge:
 - First Light -ON-
 - Second Light -BLINKING-
 - Third Light -OFF-
 - 75% - 100% Charge:
 - First and Second Light -ON-
 - Third Light - BLINKING-
 - Charge Complete
 - All Lights -ON-
 - The charger automatically shuts down to low current after charging is complete and all lights turn ON.
 - The charger continues at low current (equalizing charge) for 3-4 hours, then charging current shuts off completely.
4. Lights remain ON until the AC power supply is disconnected.

NOTE: The battery charger circuit must be used with a GFI (Ground Fault Interrupt) outlet.

NOTE: DO NOT operate the machine while the charger is plugged in.

INSPECTION AND MAINTENANCE SCHEDULE

The Complete Inspection consists of periodic visual and operational checks, along with periodic minor adjustments that assure proper performance. Daily inspection will prevent abnormal wear and prolong the life of all systems. The inspection and maintenance schedule should be performed at the specified intervals. Inspection and maintenance shall be performed by personnel who are trained and familiar with mechanical and electrical procedures.

! WARNING !

*Before performing preventative maintenance, familiarize yourself with the operation of the machine.
Always block the elevating assembly whenever it is necessary to perform maintenance while the platform is elevated.*

The daily preventative maintenance checklist has been designed for machine service and maintenance. Please photocopy the Daily Preventative Maintenance Checklist and use the checklist when inspecting the machine.

DAILY PREVENTATIVE MAINTENANCE CHECKLIST

MAINTENANCE TABLE KEY

Y = Yes/Acceptable

N = No/Not Acceptable

R = Repaired/Acceptable

PREVENTATIVE MAINTENANCE REPORT

Date: _____

Owner: _____

Model No: _____

Serial No: _____

Serviced By: _____

COMPONENT	INSPECTION OR SERVICES	Y	N	R
Battery	Check electrolyte level.			
	Check battery cable condition.			
Chassis	Check hoses for pinch or rubbing points.			
	Check welds for cracks.			
Control Cable	Check the exterior of the cable for pinching, binding or wear.			
Controller	Check switch operation.			
Drive Motors	Check for operation and leaks.			
Elevating Assembly	Inspect for structural cracks.			
Emergency Hydraulic System	Operate the emergency lowering valve and check for serviceability.			

COMPONENT	INSPECTION OR SERVICES	Y	N	R
Entire Unit	Check for and repair collision damage.			
Hydraulic Fluid	Check fluid level.			
Hydraulic Pump	Check for hose fitting leaks.			
Hydraulic System	Check for leaks.			
Labels	Check for peeling, missing, or unreadable labels & replace.			
Platform Deck and Rails	Check welds for cracks.			
Platform Deck and Rails	Check condition of deck.			
Tires	Check for damage.			

SPECIFICATIONS

ITEM	TM12
Platform Size	73,7 cm x 1,04 m (29 in. x 41 in.)
Maximum Platform Capacity	227 kg (500 lbs.)
Maximum Number of Occupants	2 People indoors/1 person outdoors
Height	
Working Height	5,83 m (19 ft.)
Maximum Platform Height	3,83 m (12.5 ft.)
Minimum Platform Height	48,3 cm (19 in.)
Dimensions	
Weight	776 kg (1710 lbs.)
Overall Width	76 cm (30 in.)
Overall Height	165 cm (65 in.)
Overall Length	1,36 m (53.5 in.)
Drive Speed	
Platform Lowered	3,65 km/h (2.27 mph)
Platform Raised	0,87 km/h (0.54 mph)
Energy Source	24V battery pack Four 220 ampere hour, 6 Volt batteries, min. wt. 26,3 kg (58 lbs.) each 4 HP DC electric motor
System Voltage	24 VDC
Battery Charger	20 AMP, 220 V AC 50Hz
Battery Duty Cycle	25% for 8 Hours
Hydraulic Reservoir Capacity	7,2 L (1.9 gal)
Maximum Hydraulic System Pressure	165 bar (2400 psi)
Hydraulic Fluid	
Normal above 32° F [0° C]	ISO #46
Low Temp. below 32° F [0° C]	ISO #32
below 0° F [-17° C]	ISO #15
Lift System	One Single Stage Lift Cylinder
Drive Control	Proportional
Control System	Proportional Control Handle with Interlock, Selector Switch, Red Mushroom Emergency Stop Switches
Horizontal Drive	Dual Front Wheel
Tires	30,5 cm (12 in.) diameter solid rubber, Non-marking
Parking Brakes	Dual, Spring Applied, Hydraulic Release
Turning Radius	37 cm (14.5 in.) Inside
Maximum Gradeability	14° (25%)
Wheel Base	97,8 cm (38.5 in.)
Guardrails	1,10 m (43 in.)
Toeboard	152 mm (6 in.)
Noise Level	

*Specifications are subject to change without notice. Hot weather or heavy use may affect performance.

Refer to the Service Manual for complete parts and service information.

This machine meets or exceeds all applicable CE and GS machinery directive requirements.

Local Distributor:

Distributeur local:

El Distribuidor local:

Snorkel International Inc.

P.O. Box 1160

St. Joseph, MO 64502-1160 USA

TEL: + 1-800-255-0317

Snorkel

www.snorkelusa.com

Serial number 505114-101