

Snorkel

Operator's Manual

SP17
SP18

Diesel Powered



LIMITED WARRANTY

Snorkel warrants each new machine manufactured and sold by it to be free from defects in material and workmanship for a period of one (1) year from date of delivery to a Customer or for one year after the machine has been placed in first service in a Dealer rental fleet, whichever comes first. Any part or parts which, upon examination by the Snorkel Service Department, are found to be defective, will be replaced or repaired, at the sole discretion of Snorkel, through its local Authorized Dealer at no charge.

Snorkel further warrants the structural components; specifically, the mainframe chassis, turntable, booms and scissor arms, of each new machine manufactured by it to be free from defects in material and workmanship for an additional period of four (4) years. Any such part or parts which, upon examination by the Snorkel Service Department, are found to be defective will be replaced or repaired by Snorkel through its local Authorized Dealer at no charge; however, any labor charges incurred as a result of such replacement or repair will be the responsibility of the Customer or Dealer.

The Snorkel Service Department must be notified within forty-eight (48) hours of any possible warranty situation during the applicable warranty period. Personnel performing warranty repair or replacement must obtain specific approval by Snorkel Service Department prior to performing any warranty repair or replacement.

Customer and Dealer shall not be entitled to the benefits of this warranty and Snorkel shall have no obligations hereunder unless the "Pre-Delivery and Inspection Report" has been properly completed and returned to the Snorkel Service Department within ten (10) days after delivery of the Snorkel product to Customer or Dealer's rental fleet. Snorkel must be notified, in writing, within ten (10) days, of any machine sold to a Customer from a Dealer's rental fleet during the warranty period.

At the direction of the Snorkel Service Department, any component part(s) of Snorkel products to be replaced or repaired under this warranty program must be returned freight prepaid to the Snorkel Service Department for inspection. All warranty replacement parts will be shipped freight prepaid (standard ground) from the Snorkel Service Department or from Snorkel's Vendor to Dealer or Customer.

REPLACEMENT PARTS WARRANTY

Any replacement or service part made or sold by Snorkel is not subject to the preceding **Limited Warranty** beyond the normal warranty period of the machine upon which the part was installed.

THIS WARRANTY EXCLUDES AND SNORKEL DOES NOT WARRANT:

1. Engines, motors, tires and batteries which are manufactured by suppliers to Snorkel, who furnish their own warranty. Snorkel will, however, to the extent permitted, pass through any such warranty protection to the Customer or Dealer.
2. Any Snorkel product which has been modified or altered outside Snorkel's factory without Snorkel's written approval, if such modification or alteration, in the sole judgment of Snorkel's Engineering and/or Service Departments, adversely affects the stability, reliability or service life of the Snorkel product or any component thereof.
3. Any Snorkel product which has been subject to misuse, improper maintenance or accident. "Misuse" includes but is not limited to operation beyond the factory-rated load capacity and speeds. "Improper maintenance" includes but is not limited to failure to follow the recommendations contained in the Snorkel Operation, Maintenance, Repair Parts Manuals. Snorkel is not responsible for normal maintenance, service adjustments and replacements, including but not limited to hydraulic fluid, filters and lubrication.
4. Normal wear of any Snorkel component part(s). Normal wear of component parts may vary with the type application or type of environment in which the machine may be used; such as, but not limited to sandblasting applications.
5. Any Snorkel product that has come in direct contact with any chemical or abrasive material.
6. Incidental or consequential expenses, losses, or damages related to any part or equipment failure, including but not limited to freight cost to transport the machine to a repair facility, downtime of the machine, lost time for workers, lost orders, lost rental revenue, lost profits or increased cost.

This warranty is expressly in lieu of all other warranties, representations or liabilities of Snorkel, either expressed or implied, unless otherwise amended in writing by Snorkel's President, Vice President-Engineering, Vice President-Sales or Vice President-Marketing.

SNORKEL MAKES NO WARRANTIES WHICH EXTEND BEYOND THE DESCRIPTION OF THIS LIMITED WARRANTY. SNORKEL MAKES NO IMPLIED WARRANTY OF MERCHANTABILITY OR FITNESS FOR A PARTICULAR PURPOSE AND DISCLAIMS ALL LIABILITY FOR INCIDENTAL OR CONSEQUENTIAL DAMAGES, INCLUDING BUT NOT LIMITED TO INJURY TO PERSONS OR PROPERTY.

The Customer shall make all warranty claims through its local Authorized Dealer and should contact the Dealer from whom the Snorkel product was purchased for warranty service. Or, if unable to contact the Dealer, contact the Snorkel Service Department for further assistance.

Effective July 1995

■ Electrical Hazard Warning



DANGER

SP ELEVATING WORK PLATFORMS ARE NOT ELECTRICALLY INSULATED.

If the platform, booms, or any other conductive part of an SP contacts a high-voltage electrical conductor, the result can be **SERIOUS INJURY** or **DEATH** for persons on or near the machine.



**GO NO CLOSER THAN THE MINIMUM SAFE APPROACH DISTANCES
(M.S.A.D) - AS OUTLINED IN TABLE 1. AND FIGURE 1.,
ON THE NEXT PAGE.**

Be sure to allow for sag and sway in the wires and the work platform.

If an SP comes in contact with a live electrical conductor, the entire machine can be charged.

If that happens, you should remain on the machine and not contact any other structure or object within reach. That includes the ground, adjacent buildings, poles, and any object not a part of the SP.

Such contact could make your body a conductor to the other object creating an electrical shock hazard resulting in **SERIOUS INJURY** or **DEATH**.

DO NOT attempt to enter or leave the SP until you are sure the electricity has been turned off.

If an SP is in contact with a live conductor, the platform operator **MUST** warn others on the ground in the vicinity of the SP to **STAY AWAY** from the machine, since their bodies can also form a path for electricity to ground thus creating an electrical shock hazard with possible **ELECTROCUTION** and **DEATH**.

DO NOT attempt to operate SP ground controls when the platform, scissors arm assembly, or any other conducting part of the SP is in contact with electrical wires or if there is an immediate danger of such contact.

Regard all conductors as energized.

Personnel working on or near an SP must be continuously aware of electrical hazards, recognizing that **SERIOUS INJURY** or **DEATH** can result if contact with an electrical wire does occur.

Operators must check local power regulations before using the SP unit near power lines

Electrical Hazard

■ Minimum Safe Approach Distance

An SP is an all metal **NOT ELECTRICALLY INSULATED**, aerial work platform. **DO NOT** operate it near **ELECTRICAL** conductors. Regard all conductors as being energized. Use the table and illustration below to determine safe clearance from electrical conductors. (Table 1 and Figure 1, below, are from ANSI/SIA A92.6–1990 Standard, reprinted with permission of Scaffold Industry Association.)

□ Table 1 - (M.S.A.D.)

**Minimum Safe Approach Distance
to energized (exposed or insulated power lines)**

Voltage range (phase to phase)	Minimum safe approach distance	
	(Feet)	(Meters)
0 to 300V	Avoid contact	
over 300v to 50kv	10	3.05
over 50kv to 200kv	15	4.60
over 200kv to 350kv	20	6.10
over 350kv to 500kv	25	7.62
over 500kv to 750kv	35	10.67
over 750kv to 1000kv	45	13.72

□ Figure 1 - (M.S.A.D.)

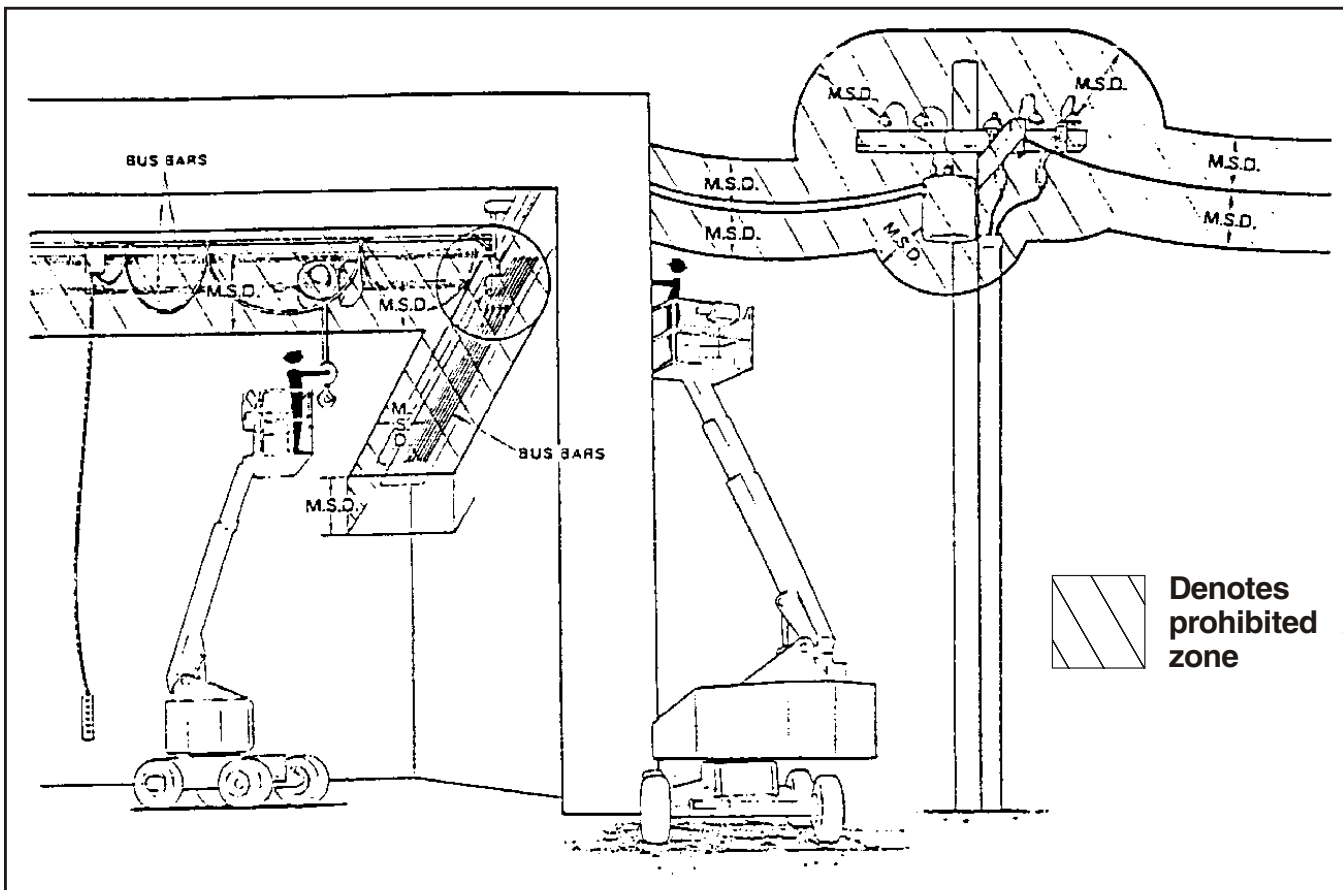

The most important chapter in this manual is the safety chapter - Chapter 1. Take time, now, to study it closely.

The information in Chapter 1, might save your life, prevent serious injury, or damage to property or the SP17 / SP18.

■ Standard SP17 / SP18

The standard SP17 / SP18 includes the following features:

- 4 degree level sensor
- Foam filled tyres
- Three section telescoping boom, steel base boom & aluminium intermediate & tip booms
- Automatic terrain following steer axle
- 4 wheel drive
- Hour meter, high engine temperature and low oil pressure shut down
- Proportional drive lift and slew
- Drive motion alarm
- Manual bleed down at chassis
- 180° hydraulic platform rotation
- Base controls include drive & steer function
- Flashing light
- 360o continuous turntable rotation
- -72° / +72° articulating boom

■ Options

The following options are available for the SP17 / SP18:

- Non marking tyres
- Harsh environment kit
- Platform control box cover
- Driving lights
- Platform work lights
- AC generator
- 8' aluminium platform
- Air line to platform
- Bump guard
- Sound suppression kit
- 240V outlet

■ Operation Manual

This manual provides information for safe and proper operation of the aerial platform. Read and understand the information in this Operator's manual before operating this machine on a job site.

Additional copies of this manual may be ordered from Snorkel. Supply the model and manual part number from the front cover to assure that the correct manual will be supplied.

All information in this manual is based on the latest product information at the time of publication. Snorkel reserves the right to make product changes at any time without obligation.

■ Photographs

Photographs are taken to represent the machine and its component parts as clearly as possible. However, there may be minor differences between the photographs and your machine. This represents individual customer preferences and Snorkel's on-going commitment to product development.

■ Safety Alerts

A safety alert symbol is used throughout this manual to indicate danger, warning, caution, and important instructions. Follow these instructions to reduce the likelihood of personal injury, property damage, or damage to the machine.

The terms danger, warning, and caution indicate varying degrees of personal injury or property damage that can result if the instruction is not followed.

▲ DANGER

Denotes an imminently hazardous situation which, if not avoided will result in death or serious injury.

▲ WARNING

Denotes a potentially hazardous situation which, if not avoided, could result in death or serious injury.

▲ CAUTION

Denotes a potentially hazardous situation which, if not avoided may result in minor or moderate injury.

It may also be used to alert against unsafe practices or action which may result in damage to the SP.

▲ IMPORTANT

Denotes important information pertaining to settings, capacities, conditions, which could, if ignored lead to machine damage or future hazardous situations.

Introduction

It may also be used to alert the reader to pay careful attention to a particular passage of text in the manual.

Notes

Notes are used to provide special information or helpful hints to assist in aerial platform operation, but do not indicate a hazardous situation.

■ Operation

The SP aerial platform has built-in safety features and has been factory tested for compliance with Snorkel specifications and industry standards. However, any personnel lifting device can be potentially dangerous in the hands of untrained or careless operators.

Training is vitally important and must be performed under the direction of a QUALIFIED person. You must display proficiency in knowledge and actual operation of the SP before using it on a job site.

Before operation of the SP you must read and understand the operating instructions in this manual as well as the decals, warnings, and instructions on the machine itself.

Before operating the SP you must be AUTHORIZED by the person in charge to do so and the operation of the SP must be within the scope of the machine specifications.

▲ WARNING

The potential for an accident increases when the aerial platform is operated by personnel who are not trained and authorized. Death or serious injury can result from such accidents.

Read and understand the information in this manual and on the placards and decals on the machine before operating the SP on the job.

■ Maintenance

Every person who maintains, inspects, tests, or repairs these machines, and every person supervising any of these functions, must be properly trained and qualified to do so.

This Operators Manual provides a daily inspection procedure that will help you keep your SP in good operating condition.

Do not perform other maintenance unless you are a trained mechanic, qualified to work on the SP. Call qualified maintenance personnel if you find problems or malfunctions.

Do not modify this machine without written approval from the Engineering Department of Snorkel. Modification may void the warranty, adversely affect stability, or affect the operational characteristics of the SP.

■ Responsibilities of Parties

▲ IMPORTANT

It is imperative that all owners and users of the SP read, understand, and conform to all applicable regulations.

Ultimate compliance to OSHA regulations is the responsibility of the user and their employer.

▲ IMPORTANT

ANSI Standard A92.6-1999 clearly identifies requirements of all parties who might be involved with Self-Propelled Elevating Work Platforms.

AUSTRALIAN / NZ STANDARD 2550-10 1994 also identifies the requirements of all parties who might be involved with Boom-Supported Elevating Work Platforms.

Note - Standards

It is the responsibility of the owner to ensure that the person operating the SP is provided with all the relevant information relating to standards, codes of practice, and local body regulations applicable in their region.

In summary

- Only trained and authorised operators should be permitted to operate the equipment.
- All manufacturers operating instructions and safety rules and all employers safety rules and all OSHA and other government safety rules should be strictly adhered to.
- Repairs and adjustments should be made only by qualified and trained maintenance personnel.
- No modification should be made to the equipment without prior written consent of the Snorkel Engineering Department.
- Make a pre-start inspection of the SP at the beginning of each shift. A malfunctioning machine must not be used.
- Make an inspection of the work place to locate possible hazards before operating the SP.

■ Additional Information

For additional information, contact your local dealer or Snorkel at:

Snorkel International, 2/26 Redfern Street
Wetherill Park NSW 2164
Australia

Snorkel International, PO Box 1041
Levin 5500
New Zealand

Electrical Hazard

Electrical Hazard Warning	-i
Minimum Safe Approach Distance	-ii
Table 1 - (M.S.A.D.)	-ii
Figure 1 - (M.S.A.D.)	-ii

Introduction

Standard SP17 / SP18	-iii
Options	-iii
Operation Manual	-iii
Photographs	-iii
Safety Alerts	-iii
Operation	-iv
Maintenance	-iv
Responsibilities of Parties	-iv
Additional Information	-v

Chapter 1. Specifications

Component Identification	1-1
Working Envelope—SP17	1-2
Working Envelope—SP18	1-3
General Specifications—SP17	1-4
General Specifications—SP18	1-5
Engine Specifications	1-6
Engine Oil Viscosity	1-6

Chapter 2. Safety

Safety Overview	2-1
Electrocution Hazards	2-1
Minimum Safe Approach Distance	2-1
Use of the Aerial Work Platform	2-1
Safe Operation	2-2
Pre-start Inspection	2-2
Work Place Inspection and Practices	2-2
Electrocution	2-3
Tipover and Falling Hazards	2-3
Crushing	2-3
Special Limitations	2-3
Manual Force	2-3
General Safety Precautions	2-3
Personnel Precautions	2-3
Operator General Precautions	2-3
Mounting and Dismounting Precautions	2-4
Starting and Stopping Precautions	2-4
Operating Precautions	2-4
Operator Maintenance Precautions	2-4
Electrical System	2-4
Hydraulic System	2-4
Fuel Handling Precautions	2-4
Safety Decals and Placards	2-5
Beaufort Scale	2-5
Safety Placards and Decals Drawing 1	2-6
Safety Placards and Decals Drawing 2	2-7

Chapter 3. Safety Devices

Emergency Stop Controls	3-1
At ground control box	3-1
At platform control box	3-1
Emergency Power System	3-1
Manual Lowering Knob	3-1
Platform Foot Switch	3-2
Guardrails	3-2
Lanyard Anchors	3-2
Horn	3-2
Tilt Alarm	3-2
All Motion Alarm	3-2
Load Sensing System	3-2
Flashing Light	3-3
Driving Lights	3-3
Platform Working Lights	3-3

Chapter 4. Gauges and Displays

Hour Meter	4-1
Alternator Warning Lamp	4-1
Engine Air Filter Gauge	4-1
Fuel	4-1
Engine Oil	4-1
Hydraulic Fluid Filter Gauge	4-2
Tilt Sensor Indicator	4-2

Chapter 5. Shut-offs and Circuit Breakers

Automatic Shut-offs	5-1
Engine temperature (Cummins engine)	5-1
Engine temperature (Deutz engine)	5-1
Engine oil pressure	5-1
Dynamic brakes	5-1
Platform height vs. drive speed	5-1
Axle lockout	5-1
Circuit Breakers	5-1
Main circuit breakers	5-1
RCD / ELCB	5-2

Chapter 6. Controls

Chassis Controls	6-1
Battery Disconnect Switch	6-1
Ground Controls	6-1
Ground controls	6-1
Platform Controls - Electric Controls	6-2
Platform controls - electric controls	6-2
Platform Controls - Hydraulic Controls	6-3
Platform controls - hydraulic controls	6-3
Platform Foot Switch	6-4
AC Generator (Optional)	6-4

Chapter 7. Pre-operational Inspection

Operator's Manual	7-2
-------------------------	-----

Table of contents

Engine	7-2
Oil Level	7-2
Cooling	7-2
Fuel Tank	7-3
Fuel Line	7-3
Air Filter	7-3
Electrical System	7-4
Battery Fluid Level	7-4
Battery Terminals	7-4
Cables and Wiring Harness	7-4
Hydraulic System	7-4
Fluid Level	7-4
Fluid Filter	7-5
Hoses, Tubes, and Fittings	7-5
Tires and Wheels	7-5
Foam Filled	7-5
Ground Control Station	7-5
Operating Controls	7-5
Emergency Stop	7-6
Emergency Power	7-6
Emergency Lowering	7-6
Level Sensor	7-6
Flashing Lights	7-7
Hostile Environment Kit (Option)	7-7
Structures	7-7
Weldments	7-7
Slide Pads	7-7
Fasteners	7-7
Wire Ropes	7-7
Platform Control Station	7-8
Guardrail System	7-8
Lanyard Anchors	7-8
Platform Control Station	
Operating Controls (Electric Controls)	7-8
Foot switch	7-8
Movement controls	7-8
Emergency Stop	7-9
Emergency Power	7-9
Horn	7-9
Operating Controls - Hydraulic Controls	7-9
Foot switch	7-9
Movement controls	7-9
Emergency Stop	7-9
Emergency Power	7-10
Horn	7-10
RCD / ELCB Outlet	7-10
Slew Lock	7-10
Air Line	7-10
All Motion Alarm	7-10
Driving and Work Lights	7-10
Platform Control Cover	7-10
Placards and Decals	7-11
Decal inspection drawing 1	7-12
Decal inspection drawing 2	7-13

Chapter 8. Operation

Operating procedures	8-1
Preparing for Operation	8-1
Control Stations	8-1
Ground Controls	8-1
Platform Controls	8-2
Boom Operation	8-3
Driving	8-3
Steering	8-3
Electrical Power Outlet	8-3
Air Line	8-4

Chapter 9. Emergency Operation

Emergency Power System	9-1
Ground Controls	9-1
Platform Controls	9-1
Emergency Lowering	9-2
Towing	9-2

Chapter 10. Stowing and Transporting

Stowing	10-1
Transporting	10-1
Driving	10-1
Winching	10-2
Hoisting	10-3
Securing for Transport	10-3

Chapter 11. Options

Platform Control Box Cover	11-5
Harsh Environment Kit	11-5
Optional Tow Kit	11-5

Chapter 12. Fire Fighting & Chemical Control

Hazardous Components	12-9
Antifreeze (UN 1993)	12-9
Battery, Lead/Acid (UN 2794)	12-9
Diesel Fuel (NA 1993)	12-9
Foam In Tires	12-10
Gasoline (UN 1203)	12-10
Hydraulic Oil (UN 1270)	12-11
Liquefied Petroleum Gas (UN 1075)	12-11
Motor Oil (UN 1270)	12-11

Chapter 13. Troubleshooting

Troubleshooting Chart	13-1
-----------------------	------

Appendix A. Glossary

■ Component Identification

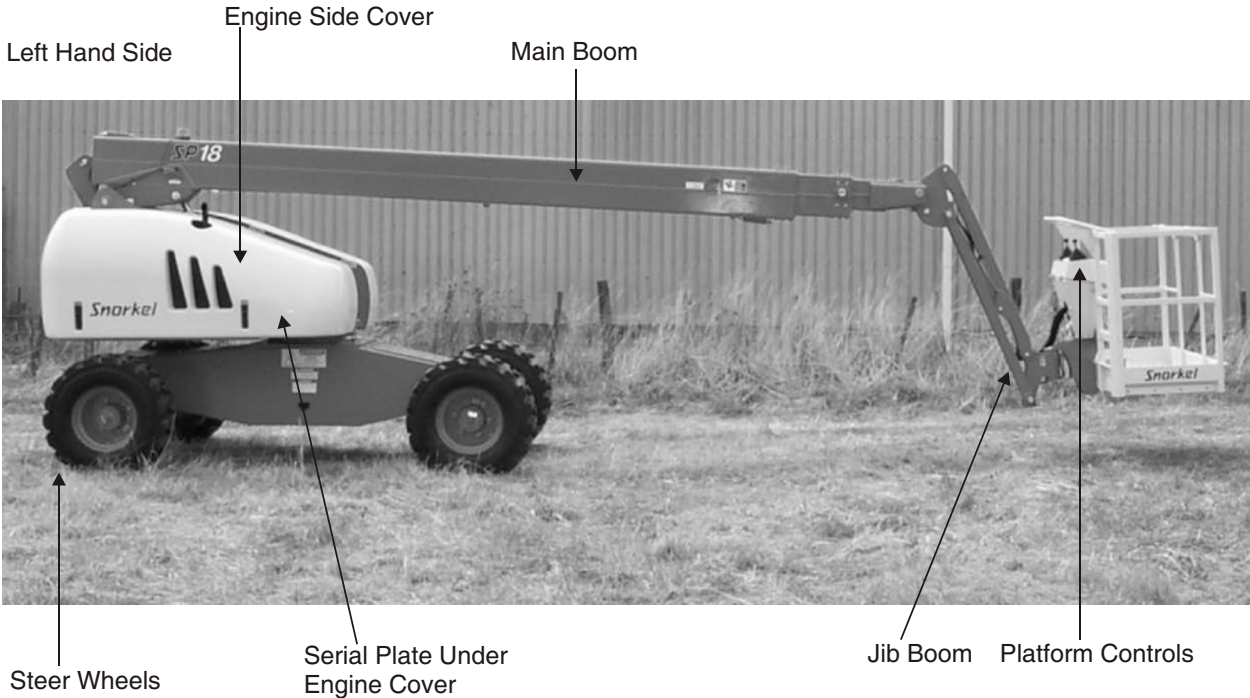

Chapter 1. Specifications

■ Working Envelope—SP17

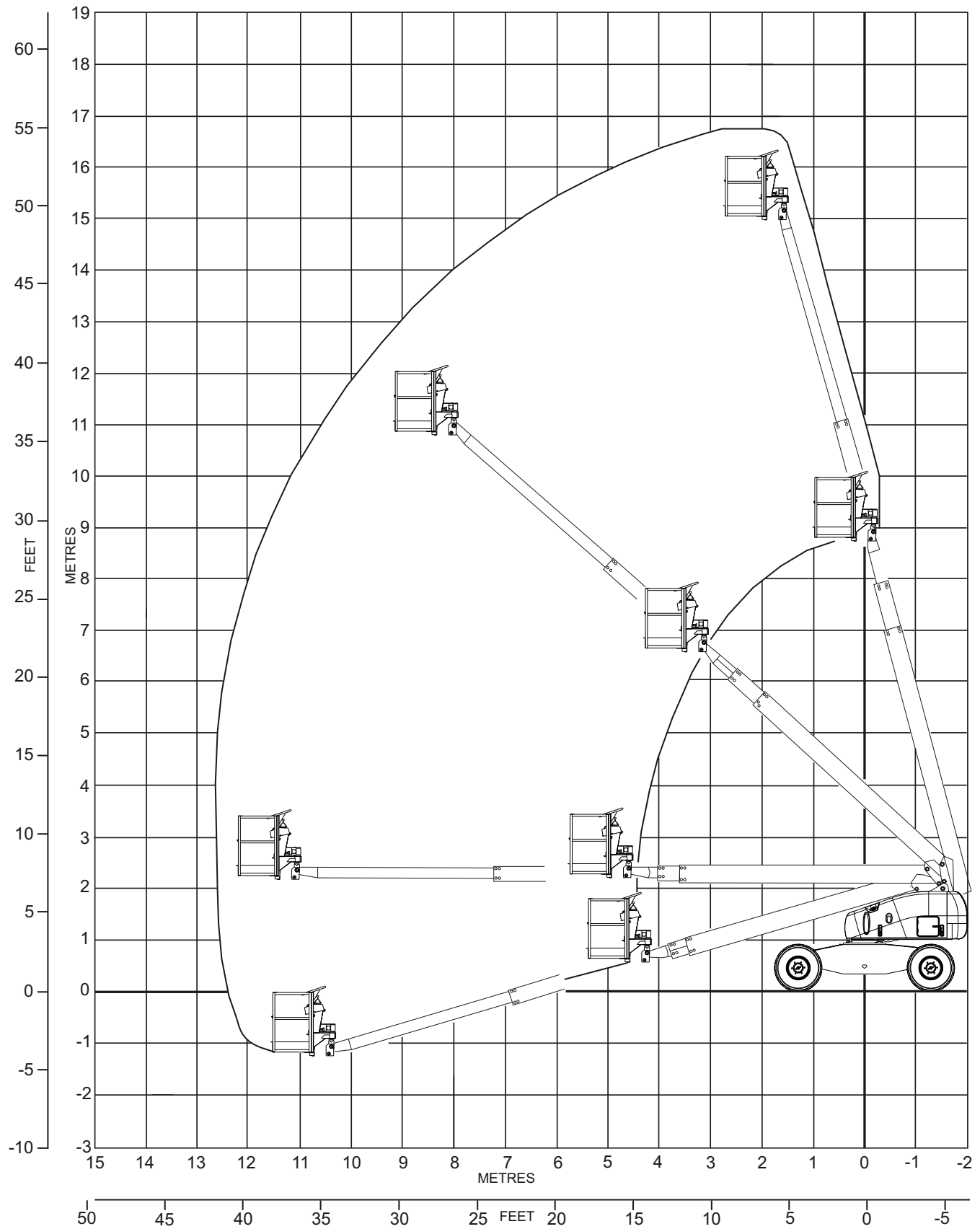

■ Working Envelope—SP18

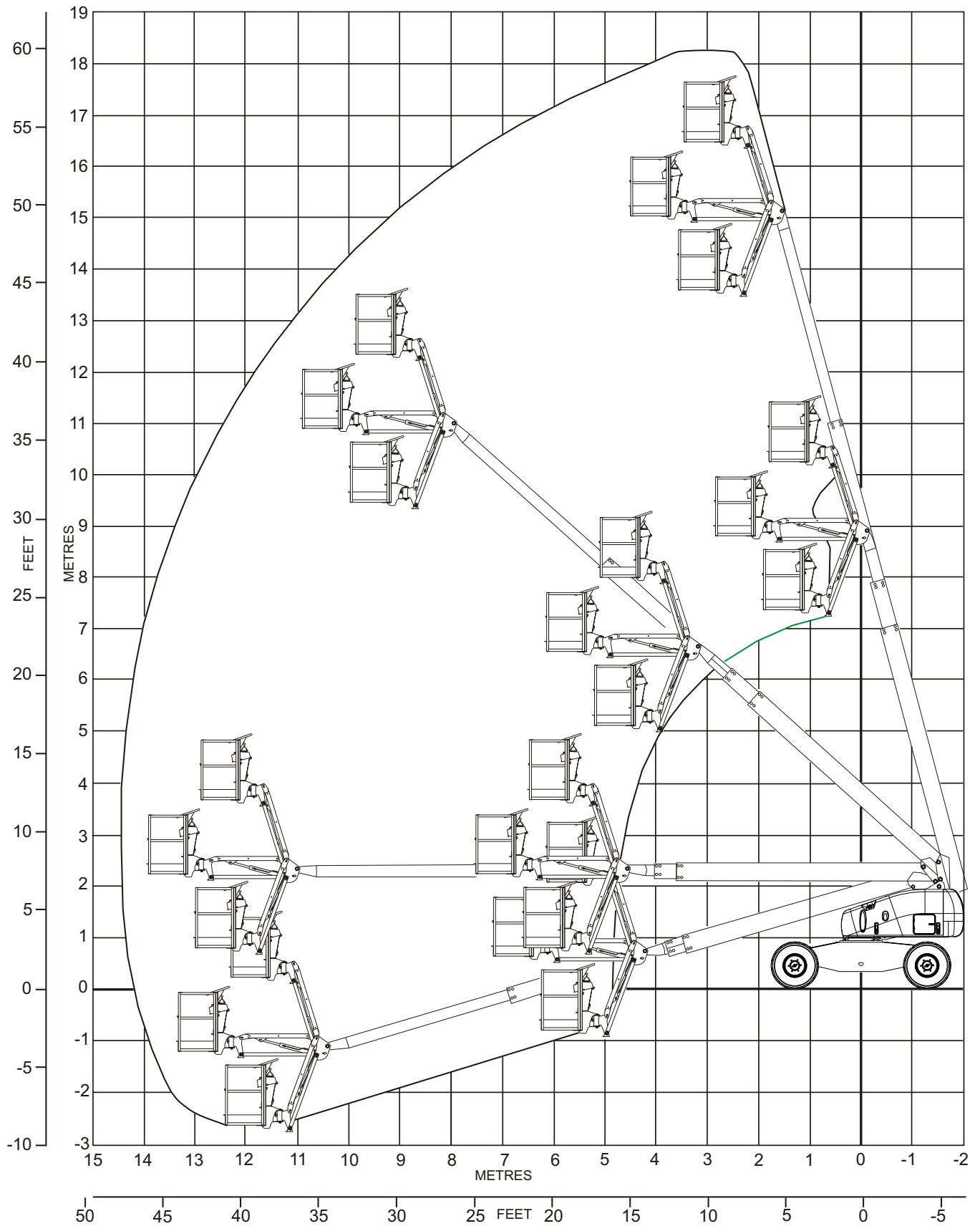

Chapter 1. Specifications

■ General Specifications—SP17

Working height	16.8m (55' 1")	Maximum single wheel load	2995kg (6603 lb)
Maximum platform height	15m (49' 2")	Weight	5800kg (12784 lb)
Horizontal outreach	12.2m (40')	Ground bearing strength	
Turntable rotation	360° continuous	Minimum	335kPa (48 psi)
Main boom		Electrical system	
Articulation	-16° to +75°	Voltage	12 V DC negative chassis ground
Platform		Source	1 - 12 V 15 plate 600 CCA battery
Dimensions		Fluid recommended	distilled water
Standard	780 x 1720mm (30.7" x 67.7")	Hydraulic system	
Optional	780 x 2440 (30.7" x 96")	Maximum pressure	3250 psi (224 bar)
Guardrail height	1100mm (43.3")	Reservoir capacity	100 litres (26.3 US gal)
Rated work load	227 kg (500 lb)	System capacity	129 litres (33.9 US gal)
Rotation	180°	Maximum operating temperature . . .	93°C(200°F)
Maximum number of occupants	2 people	Hydraulic fluid recommended	
Cycle times		Shell Tellus T37	
Turntable rotation	115/120 sec	Engine	Deutz F3L2011F
Main boom		Fuel tank capacity	100 litres (26.3 US gal)
Up	45/55 sec	Ambient air temperature operating range	
Down	35/45 sec	Celsius	-18°C to 43°C
Extend	55/65 sec	Fahrenheit	0°F to 110°F
Retract	45/55 sec	Maximum wind speed	
Platform rotation	16/20 sec	12.5m/sec	45 km/h (28 mph)
Drive system			
Standard	4-wheel drive		
Steering system			
Standard	2-wheel steer		
Tires, 14ply			
Foam filled	14 x 17.5 HD		
Gradeability	40%		
Drive speed			
High	4 km/h (2.5 mph)		
Low	1.6 km/h (1 mph)		
Turning radius, inside			
Inside	3.8m (12' 2")		
Outside	6.1m (20')		
Tailswing			
Stowed	270mm (10.6")		
Overside	893mm (35.1")		
Stowed height	2560mm (8' 6")		
Stowed width	2270mm		
Stowed length	7420mm		
Wheelbase	2600mm (8' 6")		
Ground clearance	440mm (17.3")		
Axle oscillation	7.8°		

■ General Specifications—SP18

Working height	18.3m (60')	Wheelbase	2600mm (8' 6")
Maximum platform height	16.5m (54' 3")	Ground clearance	440mm (17.3")
Horizontal outreach	14m (45' 11")	Axle oscillation	7.8°
Turntable rotation	360° continuous	Maximum single wheel load	3304kg (7284 lb)
Main boom		Weight	6400kg (14105 lb)
Articulation	-16° to +72°	Ground bearing strength	
Jib boom articulation	-72 to + 72 degrees	Minimum	370kPa (54 psi)
Platform		Electrical system	
Dimensions		Voltage	12 V DC negative chassis ground
Standard	780 x 1720mm (30.7" x 67.7")	Source	1 - 12 V 15 plate 600 CCA battery
Optional	780 x 2440mm (30.7" x 96")	Fluid recommended	distilled water
Guardrail height	1100mm (43.3")	Hydraulic system	
Rated work load	227 kg (500 lb)	Maximum pressure	3250 psi (224 bar)
Rotation	180°	Reservoir capacity	100 litres (26.3 US gal)
Maximum number of occupants	2 people	System capacity	129 litres (33.9 US gal)
Cycle times		Maximum operating temperature	93°C(200°F)
Turntable rotation	115/120 sec	Hydraulic fluid recommended	
Main boom		Shell Tellus T37	
Up	45/55 sec	Engine	Deutz F3L2011F
Down	35/45 sec	Fuel tank capacity	100 litres (26.3 US gal)
Extend	55/65 sec	Ambient air temperature operating range	
Retract	45/55 sec	Celsius	-18°C to 43°C
Platform rotation	30/40 sec	Fahrenheit	0°F to 110°F
Jib boom		Maximum wind speed	
Up	20/25 sec	12.5m/sec	45 km/h (28 mph)
Down	15/20 sec		
Drive system			
Standard	4-wheel drive		
Steering system			
Standard	2-wheel steer		
Tires, 14ply			
Foam filled	14 x 17.5 HD		
Gradeability	40%		
Drive speed			
High	4 km/h (2.5 mph)		
Low	1.6 km/h (1 mph)		
Turning radius, inside			
Inside	3.8m (12'2")		
Outside	6.1m (20')		
Tailswing			
Stowed	270mm (10' 6")		
Overside	893mm (35.1")		
Stowed height	2580mm (8' 5")		
Stowed width	2270mm		
Stowed length	6770mm		

Chapter 1. Specifications

■ Engine Specifications

Engine Make	Deutz	Cummins
Model	F3L-1011	B3.3
Horsepower	40.23 hp @ 3000 rpm	60 hp @ 2,500 rpm
Coolant	Air	Liquid (50% water 50% ethylene glycol)
Fuel Type	Diesel	Diesel
Grade	<ul style="list-style-type: none"> DIN 51 601 BS 2869: A1 and A2 ASTM D 975-81: 1-D and 2-D W-F-800C: DF-A, DF-1 and DF-2. 	ASTM No. 2 D Centane # >40 For operating temperatures below 32°F (0°C) use winterized No. 2D
Operating temperature	172°F to 203°F (78°C to 95°C)	141°F to 211°F (60°C to 100°C)
Oil capacity	5.51L (5.77 US qt)	7L (7.3 US qt)
Oil grade	API: CF-4 CG-4 CH-4	API: CH-4
Oil viscosity	See engine Oil Viscosity	
Oil filter capacity	0.5 L (0.52 US qt)	
Running time	One full tank of diesel will last for eight hours under normal working conditions	

■ Engine Oil Viscosity

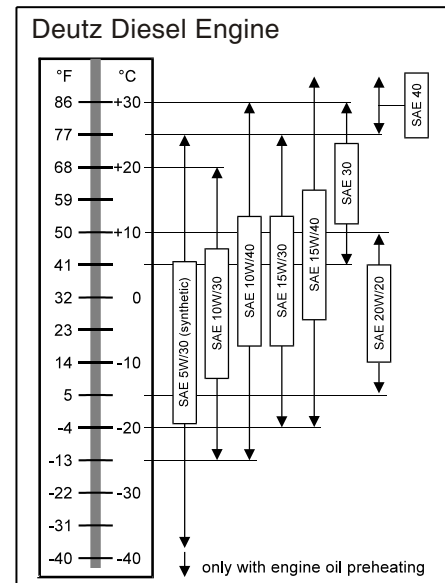
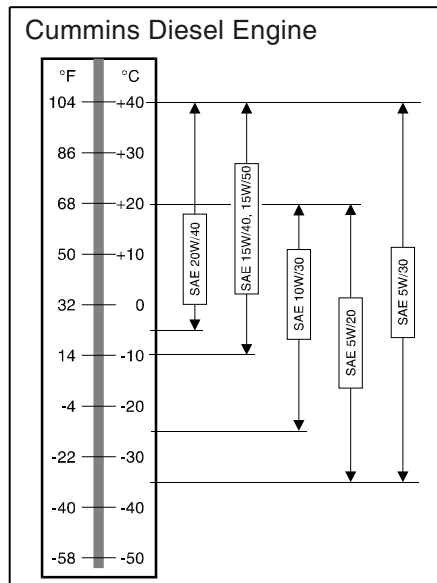

■ Safety Overview

Knowledge of the information in this manual, and proper training, provide a basis for safely operating the aerial platform. Know the location of all controls and how they operate to act quickly and responsibly in an emergency.

Safety devices reduce the likelihood of an accident. Never disable, modify, or ignore any safety device. Safety alerts in this manual indicate situations where accidents may occur.

If any malfunction, hazard or potentially unsafe condition relating to capacity, intended use, or safe operation is suspected, stop aerial platform operation and seek assistance.

The operator bears ultimate responsibility for following all manufacturer's instructions and warnings, regulations and safety rules of their employer and/or any state or federal law.

■ Electrocution Hazards

The aerial platform is made of metal components and is not insulated. Regard all conductors as energized. Do not operate outside during a thunderstorm. (See also Electrical Hazard section at the beginning of this manual).

▲ DANGER

The aerial platform is not electrically insulated. Death or serious injury can result from contact with, or inadequate clearance from, an energized conductor. Do not go closer than the minimum safe approach distance as defined by ANSI.

ANSI publications define minimum distances that must be observed when working near bus bars and energized power lines.

□ Minimum Safe Approach Distance

Minimum safe approach distances to energized power lines and their associated parts must be observed while operating the aerial platform

▲ DANGER

Operators must check local power regulations before using the SP unit near power lines.

THIS AERIAL WORK PLATFORM IS NOT INSULATED! For this reason it is imperative to keep a safe distance from live parts of electrical equipment. (See Electrical Hazard Section at the beginning of this manual)

□ Use of the Aerial Work Platform

The SP17/SP18 aerial work platform is intended to lift personnel and their tools, as well as the material used for the job.

It is designed for repair and assembly jobs and assignments at overhead workplaces (ceilings, cranes, roof structures, buildings etc.).

All other uses of the aerial work platform are prohibited!

Exceeding the specified permissible maximum load **is prohibited!** See Specifications Chapter page for details.

The use and operation of the aerial work platform as a lifting tool or crane (lifting of loads from below upwards or from a height to the ground) **is prohibited!**

NEVER exceed the manual force allowed for this machine. See Special Limitations on page of this chapter for details.

DISTRIBUTE all platform loads evenly on the platform.

NEVER operate the machine without first surveying the work area for surface hazards such as holes, drop-offs bumps, curbs, or debris, and avoiding them.

OPERATE the machine only on surfaces capable of supporting wheel loads.

NEVER operate the machine when wind speeds exceed this machines rating. See Beaufort Scale on page 5 of this chapter for details.

IN CASE OF EMERGENCY push the **EMERGENCY STOP** to deactivate all powered functions.

Climbing up the railing of the platform, standing on or stepping from the platform onto buildings, steel or prefab concrete structures, etc., **is prohibited!**

IF AN ALARM SOUNDS while the platform is elevated, **STOP**, and carefully lower the platform. Move the machine to a firm, level surface.

Bypassing any safety equipment **is prohibited** and presents a danger for the persons on the aerial work platform and its working range.

Dismantling the entry gate or other railing components **is prohibited!** Always make certain that the entry gate is closed and securely locked!

It is prohibited to keep the entry gate in an open position (held open with tie-straps) when the platform is raised!

Chapter 2. Safety

Extending the height or the range of the platform by placing ladders, scaffolds, or similar devices on the platform **is prohibited!**

NEVER perform service on the machine while the platform is elevated without blocking the elevating assembly.

INSPECT the machine thoroughly for cracked welds, loose or missing hardware, hydraulic leaks, loose wire connections, and damaged cables before using.

VERIFY that all labels are in place and legible before using the machine.

NEVER use a machine that is damaged, not functioning properly, or has damaged or missing labels.

NEVER charge batteries near sparks or open flames. Charging batteries emit explosive hydrogen gas.

Modifications to the aerial work platform **are prohibited** or permissible only with the approval of Snorkel.

AFTER USE, secure the SP17/SP18 from unauthorized use by turning the key switches off and removing the key.

■ Safe Operation

The following safety information is vitally important for safe operation of the SP. Failure to follow these instructions can result in personal injury or **DEATH**.

□ Pre-start Inspection

At the start of each work shift, the SP shall be given a visual inspection and function test. See the Pre-operational Inspection chapter 7, in this manual for a list of items to inspect and test.

▲ CAUTION

DO NOT operate the SP unless you are trained and authorized, understand the operation characteristics of the SP, and have inspected and tested all functions to be sure they are in proper working order.

□ Work Place Inspection and Practices

Do not use the SP as a ground for welding. Ground to the work piece.

Before the SP is used, and during use, check the area in which the SP is to be used for possible hazards such as, but not limited to:

- Drop-offs or holes.

- Side slopes.
- Bumps and floor obstructions.
- Debris.
- Overhead obstructions and electrical conductors.
- Hazardous locations.
- Inadequate surface and support to withstand all load forces imposed by the aerial platform in all operating configurations.
- Wind and weather conditions.
- Presence of unauthorized persons.
- Other possible unsafe conditions.

A recommended safety practice is to have personnel that are trained in the operation of the emergency controls working in the immediate area of the SP to assist the platform operator in the event of an emergency to:

- Help in case of an emergency
- Operate emergency controls as required
- Watch for loss of control by platform operator
- Warn the operator of any obstructions or hazards that may not be obvious to them
- Watch for soft terrain, sloping surfaces, drop-offs, etc. where stability could be jeopardized

Watch for bystanders and never allow anyone to be under, or to reach through the booms while operating the aerial platform

▲ DANGER

Pinch points may exist between moving components. Death or serious injury can result from becoming trapped between components, buildings, structures or other obstacles. Make sure there is sufficient clearance around the machine before moving the chassis, booms, or platform. Allow sufficient room and time to stop movement to avoid contact with structures or other hazards.

When moving the platform, check the clearance around the SP to avoid contact with structures or other hazards. Always look in the direction of motion.

Keep ground personnel from under the platform when the platform is raised.

Note - Lowering:

When lowering the platform, pay special attention to see that there are no people near or approaching the machine. Should this be the case, interrupt the lowering process immediately. Continue lowering the platform only when any people who were too near the machine are out of its operating perimeter.

Secure all accessories, containers, tools, and other materials in the platform to prevent them from accidentally falling or being kicked off the platform.

DO NOT engage in any form of horseplay or stunt driving while operating the SP.

DO NOT permit riders on the machine anyplace other than on the platform.

Remove all loose objects stored in or on the machine, particularly in the platform. Remove all objects which do not belong in or on the machine.

When other moving equipment is in the area, take special precautions to comply with local regulations regarding warnings.

Never steady the platform by positioning it against another platform.

DO NOT operate an SP that is not functioning properly, or has been damaged, until the machine has been repaired by a qualified maintenance person.

DO NOT operate a SP that does not have all its decals and placards attached and legible.

Drive the machine with care and at speeds compatible with conditions. Use extra caution when driving over rough ground, on slopes, and when turning.

Know and understand the job site traffic-flow patterns and obey the flag-men, road signs, and signals.

Watch for bystanders and never allow anyone to be under, or to reach through, the machine and its equipment while operating.

Use the recommended transport device when loading the machine.

Electrocution

The SP is an all metal, NON-INSULATED, aerial work platform. **DO NOT** operate it near ELECTRICAL conductors. Regard all conductors as being energized.

DO NOT operate outside during a thunderstorm.

Tipover and Falling Hazards

DO NOT raise the platform if the SP is on soft ground. Operate the platform only on a firm surface capable of withstanding all load forces imposed by the aerial platform in all operating conditions.

▲ DANGER

The aerial platform can tip over if it becomes unstable. Death or serious injury can result from a tip-over accident. Do not drive or position the aerial platform for elevated use near any drop-off, hole, slope, soft or uneven ground, or other tip-over hazard.

Care shall be taken to prevent rope, electric cords, and hoses, etc., from becoming entangled in the aerial platform.

Crushing

Always look in the direction of travel. Avoid overhead obstructions.

Make sure the area below the platform is free of personnel before lowering.

■ Special Limitations

Manual Force

Manual force is the force applied by the occupants to objects such as walls or other structures outside the work area.

The maximum allowable manual force is limited to 200 N (45 lbs.) of force per occupant, with a maximum of 400 N (90 lbs.) for two or more occupants.

▲ DANGER

DO NOT exceed the maximum amount of manual force for this machine.

■ General Safety Precautions

Personnel Precautions

If you encounter any suspected malfunction of the aerial platform, or any hazard or potentially unsafe condition relating to capacity, intended use, or safe operation, cease operation and seek assistance from management.

Operator General Precautions

Make sure that all protective guards, cowlings, and doors are in place and secure.

Chapter 2. Safety

Be sure the guardrail system, including the gate, is in place and secure.

Mounting and Dismounting Precautions

Use three points of support when getting on or off the platform (two hands and one foot or a similar set of points). Keep the platform clean.

DO NOT jump off the machine.

DO NOT dismount while the machine is in motion.

Starting and Stopping Precautions

DO NOT start until all personnel are clearly away from the machine.

Before leaving the operators station, place the machine in the stowed position.

When leaving the machine parked or unattended, remove the starter key from the **Key** switch and set the **Battery** switch to off.

Operating Precautions

When parts or components are replaced, they shall be identical or equivalent to original Snorkel parts or components.

Operator Maintenance Precautions

Electrical System

Charge batteries in a well-ventilated area free of flame, sparks, or other hazards that might cause fire or explosion.

▲ DANGER

Batteries give off hydrogen and oxygen that can combine explosively. Death or serious injury can result from a chemical explosion. Do not smoke or permit open flames or sparks when checking the batteries.

Battery acid can damage the skin and eyes. Serious infection or reaction can result if medical treatment is not given immediately. Wear face and eye protection when working near the batteries.

Batteries contain sulfuric acid that can damage your eyes or skin on contact. Wear a face shield, rubber gloves, and protective clothing when working around batteries. If acid contacts your eyes, flush immediately with clear water and get medical attention. If acid contacts your skin, wash off immediately with clear water.

Hydraulic System

The hydraulic system contains hoses with hydraulic fluid under pressure.

▲ DANGER

DO NOT use your hand to search for hydraulic oil leaks. High pressure hydraulic oil can easily cut and penetrate your skin a very serious injury that requires immediate attention by a medical specialist trained in that type of injury. Use a piece of cardboard or wood to search for hydraulic oil leaks.

DO NOT attempt repairs unless you are trained. Refer to manuals and experienced repair personnel for help.

Fuel Handling Precautions

DO NOT smoke or permit open flames while fueling or near fueling operations.

Never remove the fuel cap or refuel a gasoline engine while the engine is running or hot. Never allow fuel to spill on hot machine components.

Maintain control of the fuel filler nozzle when filling the tank.

DO NOT fill the fuel tank to capacity. Allow room for expansion.

Clean up spilled fuel immediately.

Tighten the fuel tank cap securely. If the fuel cap is lost, replace it with an approved cap from Snorkel. Use of a non-approved cap without proper venting may result in pressurization of the tank.

Never use fuel for cleaning purposes.

For diesel engines, use the correct fuel grade for the operating season.

■ **Beaufort Scale**

Never operate an SP17/SP18 when wind speeds exceed 45 km/h (28 mph) [Beaufort scale6]

BEAUFORT SCALE	WIND SPEED				GROUND CONDITIONS
	m/s	km/h	ft/s	mph	
3	3.4~5.4	12.5~19.4	11.5~17.75	5~12.0	Papers and thin branches move, flags wave.
4	5.4~8.0	19.4~28.8	17.75~26.25	12.0~18	Dust is raised, paper whirls up, and small branches sway.
5	8.0~10.8	28.8~38.9	26.25~35.5	18~24.25	Shrubs with leaves start swaying. Wave crests are apparent in ponds or swamps.
6	10.8~13.9	38.9~50.0	35.5~45.5	24.5~31	Tree branches move. Power lines whistle. It is difficult to open an umbrella.
7	13.9~17.2	50.0~61.9	45.5~56.5	31~38.5	Whole trees sway. It is difficult to walk against the wind.

▲ DANGER

Do not add banners, flags, screens or shelters etc., to areas of the MHP that are exposed to wind forces as this will increase the wind loading and effect stability.

■ **Safety Decals and Placards**

There are several safety decals and placards on the SP. Their locations and descriptions are shown in this section. Take time to study them.

▲ CAUTION

Be sure that all the safety decals and placards on the SP are legible. Clean or replace them if you cannot read the words or see the pictures. Clean with soap & water and a soft cloth. Do not use solvents.

You MUST replace a decal or placard if it is damaged, missing, or cannot be read. If it is on a part that is replaced, make sure a new decal or placard is installed on the replaced part. See your Snorkel dealer for new decals and placards.

NOTE

Refer to Placards and Decals Inspection Chart and Drawing in the Pre-operational Inspection and Maintenance chapter , for part numbers, location, and required quantities of all placards and decals.

Chapter 2. Safety

■ Safety Placards and Decals Drawing 1

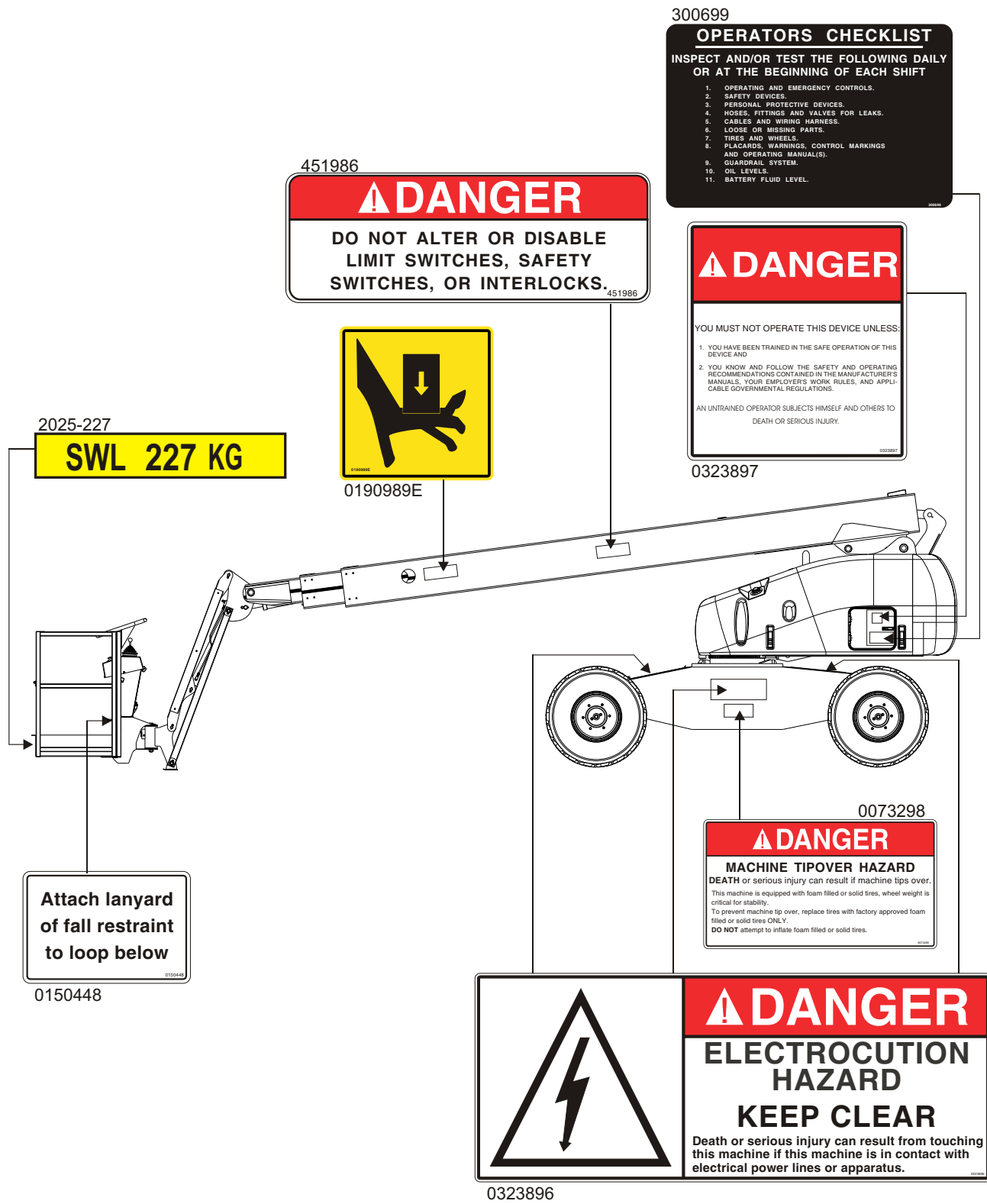

0073668

CAUTION

DO NOT USE BOOM TO LIFT OR PUSH MACHINE

0073668

Snorkel 36 Bruce Road
Levin 5500 - New Zealand

MODEL NUMBER	SERIAL NUMBER
MONTH / YEAR OF MANUFACTURE	SLOPE SENSOR ALARM SETTING deg
MAXIMUM MACHINE WEIGHT lbs / kg	MAXIMUM WHEEL LOAD lbs / kg
MAXIMUM PLATFORM HEIGHT ft / m	OUTRIGGER LOAD ft / m
MAXIMUM ALLOWABLE MANUAL FORCE (SIDE PULL) lbs / N	MAXIMUM ALLOWABLE WIND SPEED mi/h / m/s

PLATFORM CAPACITY = 227 kg = 2 PERSONS + ADD. LOAD

CAUTION

Do not remove any weight from this machine. Any weight added must be distributed equally on each axle. Proper stability and axle weights of this machine are based on the platform size shown above.

MACHINERY DIRECTIVE 98/37/CEE

DANGER

YOU MUST NOT OPERATE THIS DEVICE UNLESS:

1. YOU HAVE BEEN TRAINED IN THE SAFE OPERATION OF THIS DEVICE AND
2. YOU KNOW AND FOLLOW THE SAFETY AND OPERATING RECOMMENDATIONS CONTAINED IN THE MANUFACTURER'S MANUALS, YOUR EMPLOYER'S WORK RULES, AND APPLICABLE GOVERNMENTAL REGULATIONS.

AN UNTRAINED OPERATOR SUBJECTS HIMSELF AND OTHERS TO DEATH OR SERIOUS INJURY.

0323897

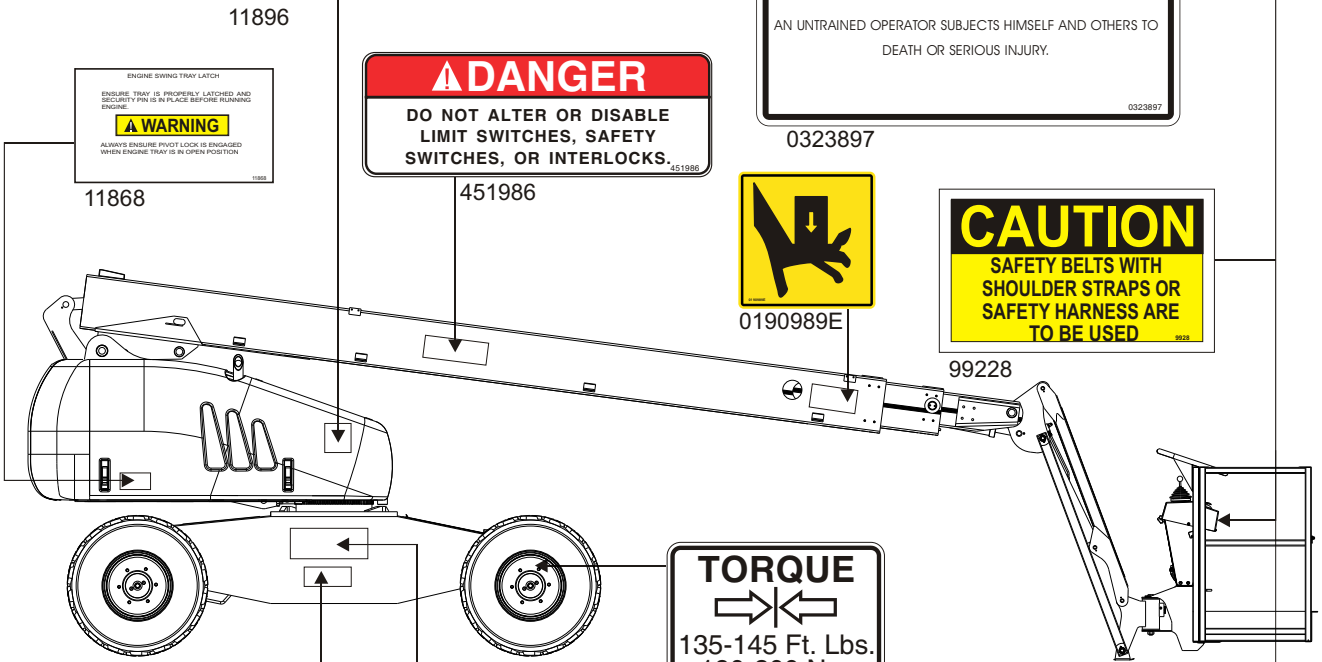

DANGER

DO NOT ALTER OR DISABLE LIMIT SWITCHES, SAFETY SWITCHES, OR INTERLOCKS.

451986



CAUTION

SAFETY BELTS WITH SHOULDER STRAPS OR SAFETY HARNESS ARE TO BE USED

99228

TORQUE

135-145 Ft. Lbs.
190-200 N·m

12044

DANGER

MACHINE TIPOVER HAZARD

DEATH or serious injury can result if machine tips over. This machine is equipped with foam filled or solid tires, wheel weight is critical for stability. To prevent machine tip over, replace tires with factory approved foam filled or solid tires ONLY. DO NOT attempt to inflate foam filled or solid tires.

0073298

DANGER

ELECTROCUTION HAZARD

THIS MACHINE IS NOT ELECTRICALLY INSULATED.

- Death or serious injury can result from contact or inadequate clearance to electrical power lines and apparatus.
- Maintain 10 feet minimum clearance from electrical power lines and apparatus.
- Allow for sway, rock, and sag.

0323899

DANGER

ELECTROCUTION HAZARD

KEEP CLEAR

Death or serious injury can result from touching this machine if this machine is in contact with electrical power lines or apparatus.

0323896

This aerial platform is manufactured with safety devices, placards, and decals to reduce the likelihood of an accident. For the safety of all personnel, do not disable, modify, or ignore any safety device. Safety devices are included in the Pre-operational Inspection.

⚠ DANGER

The potential for an accident increases when safety devices do not function properly. Death or serious injury can result from such accidents. Do not alter, disable, or override any safety device.

If any safety devices are defective, remove the aerial platform from service until qualified maintenance personnel can make repairs.

■ Emergency Stop Controls

There is an emergency stop control at the lower and upper controls.

□ At ground control box

Press the large red **EMERGENCY STOP** ① (refer to Figure 3.1) button in and the entire machine stops, the engine turns off, and nothing moves. This button must be out (on) to control the SP (pull the button and it will pop out).



Figure 3.1—Ground Controls

NOTE

The lower controls override the upper controls. If the upper control emergency stop button is engaged the lower controls can still be used to operate the aerial platform.

□ At platform control box

Press the large red **EMERGENCY STOP** ① (refer to Figure 3.2 and 3.3) button in and the entire machine stops, the engine turns off, and nothing moves. This button must be out (on) to control the

SP from the platform (pull the button and it will pop out).

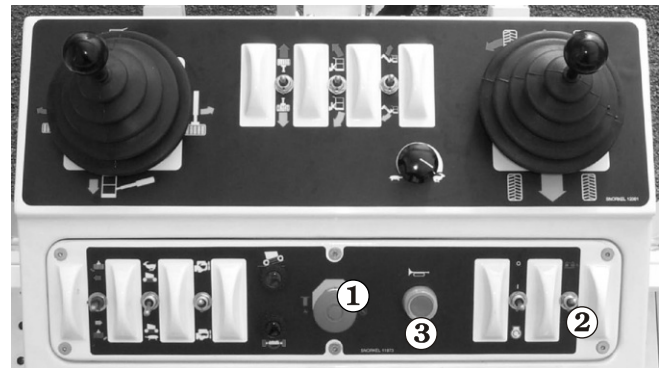

Figure 3.2—Platform Controls (Electric Controls)

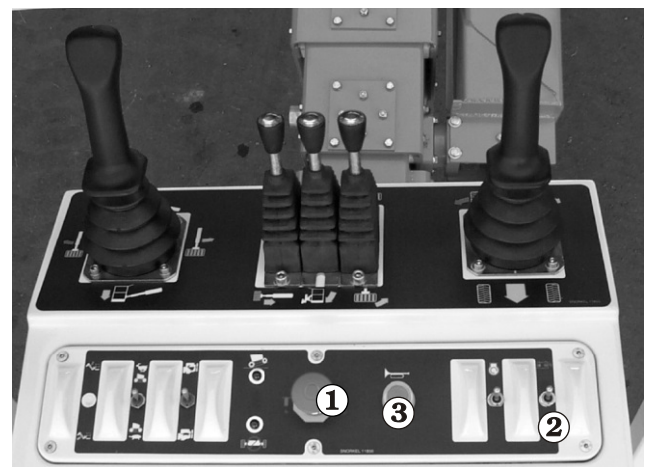

Figure 3.3—Platform Controls (Hydraulic Controls)

■ Emergency Power System

The emergency power system includes a back-up pump, motor, and battery. Use this system to operate the boom and turntable functions to lower the platform if the main power system fails due to engine or pump failure.

Operate the emergency power switch ② (refer to Figure 3.1, 3.2 and 3.3) to activate the emergency power system.

The length of time the pump can be operated depends on the capacity of the battery.

■ Manual Lowering Knob

The manual emergency lowering knob (refer to Figure 3.4) may be used to lower the booms if the engine will not start and the emergency power system will not work. The knob is located on the base control panel.



Figure 3.4—Emergency Lowering Knob

■ Platform Foot Switch

The platform foot switch (refer to Figure 3.4①) prevents boom and platform movement if a control on the upper control panel is accidentally moved.

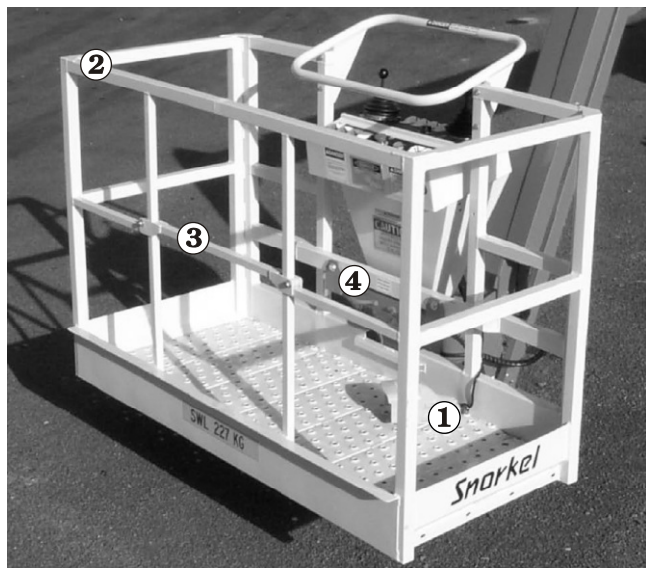

Figure 3.5—Platform

Step down on the platform foot switch to activate the boom and platform controls.

■ Guardrails

The guardrail system includes a top rail, mid rail, and toeboards around the sides of the platform (refer to Figure 3.4②).

A gravity gate or an optional swinging gate allows for access to the platform (refer to Figure 3.4③). The swinging gate closes automatically after entering or exiting the platform. The gate is part of the guardrail system and must be securely fastened after entering the platform.

■ Lanyard Anchors

Two lanyard anchors for fall restraint anchorage are provided below the upper controls at the front of the platform (refer to Figure 3.4④).

NOTE

The lanyard anchors are not for lifting or tying the machine down.

All personnel in the platform must connect their fall restraint device to a lanyard anchor before raising the platform. Do not use the aerial platform for *personal fall arrest* anchorage.

■ Horn

The horn (refer to Figure 3.2 and 3.3③) may be used to warn personnel on the ground. The horn is operational when the machine is set up for operation from the upper controls.

■ Tilt Alarm

If the aerial platform chassis is out of level more than five degrees when the main boom is raised or extended, an alarm will sound.

▲ DANGER

The aerial platform can tip over if it becomes unstable. Death or serious injury can result from a tip-over accident. Do not drive or position the aerial platform for elevated use near any drop-off, hole, slope, soft or uneven ground, or other tip-over hazard.

Completely lower and retract the main boom and then drive to a level surface when the tilt alarm sounds.

The tilt alarm is for added protection and does not justify operating on anything other than firm, flat, level surfaces.

■ All Motion Alarm

An all motion alarm is provided on the machine. When boom or drive control is moved out of neutral, the alarm sounds to warn personnel in the work area to stand clear.

■ Load Sensing System

Note

This is not a standard option and applies to CE machines only.

The load sensing system sounds an alarm and illuminates a lamp to warn the operator that the platform is overloaded.

The alarm will sound and the overload light will illuminate as soon as the overload point is reached. The lamp is mounted on the platform control box (see Figure 3.6).

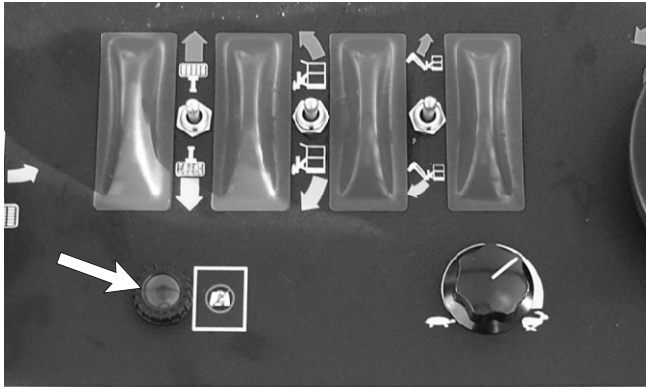

Figure 3.6—Platform Overload Light

NOTE:

When the alarm sounds all platform movement and drive functions are prevented.

The alarm and function interlock will be active until the load is reduced.

■ **Flashing Light**

An amber flashing light is located on the top of the boom. The flashing light warns personnel that the aerial platform is in the area.

The light flashes at about one flash per second when the engine is running.

■ **Driving Lights**

Optional headlights and blinking tail lights may be installed on the machine. The headlights are 30 watts each and are located on the top of the front cowling. The tail lights are 25 watts each and are mounted on the sides of the rear cowling.

Driving lights help improve visibility while driving the aerial platform and help others see it too. Driving lights are not for driving on public roadways.

■ **Platform Working Lights**

Optional platform working lights may be located on the top rail of the platform, one on each side of the upper control panel.

Use the platform lights to improve visibility while working aloft in dimly lit areas. Do not use the platform work lights to drive on public roadways.

The aerial platform is equipped with several gauges to monitor the condition of the machine before and during operation.

■ Hour Meter

The hour meter is located at the lower controls (refer to Figure 4.1). It measures the accumulated operating time.

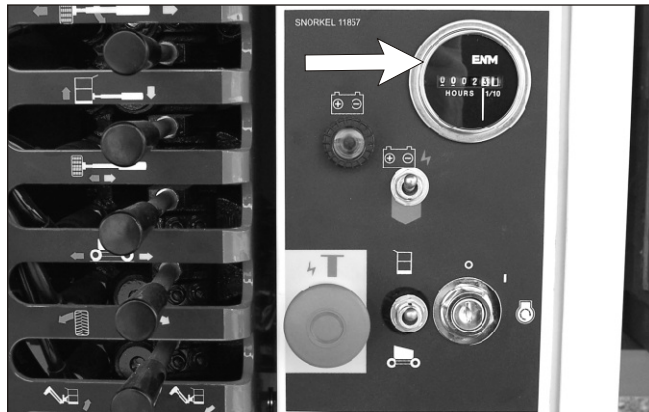

Figure 4.1—Ground Controls

■ Alternator Warning Lamp

The alternator warning lamp is located on the lower control panel just below the symbol of a battery (see Figure 4.2). If this lamp illuminates it indicates that the battery is not charging and the fault should be investigated.

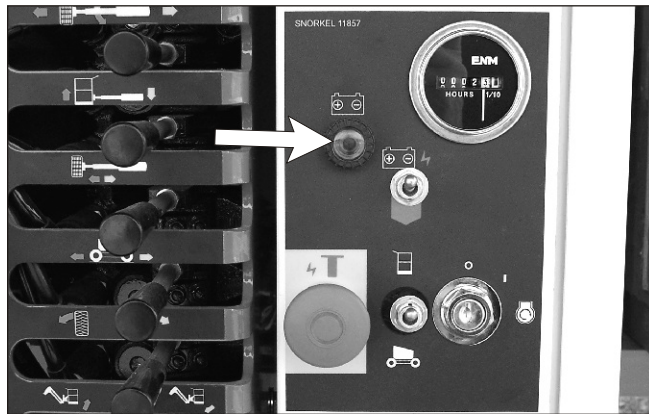

Figure 4.2—Ground Controls

■ Engine Air Filter Gauge

The air filter gauge is located under the engine cowling (refer to Figure 4.3). The gauge measures the air pressure between the intake manifold and the air filter. The yellow indicator disk raises toward the red area of the sight glass as the filter clogs.

The indicator disk stays at its highest setting and does not go to the bottom of the sight glass when the engine is turned off. When the disk reaches the red area, it's time to change the air filter.

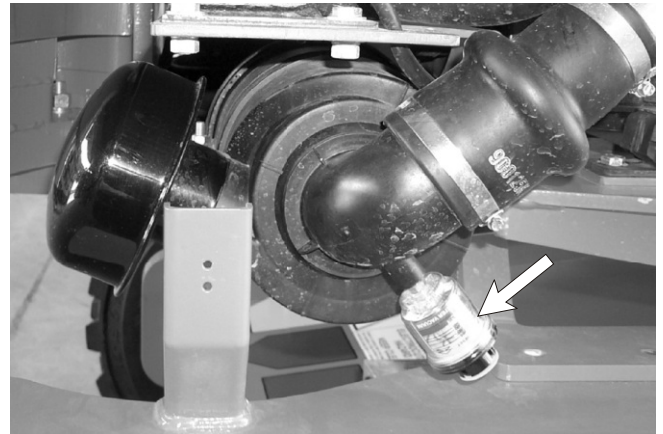

Figure 4.3—Deutz Air Filter Gauge

■ Fuel

The fuel tank (refer to Figure 4.4). Is 'see through' and this allows the operator to quickly gauge the amount of fuel.

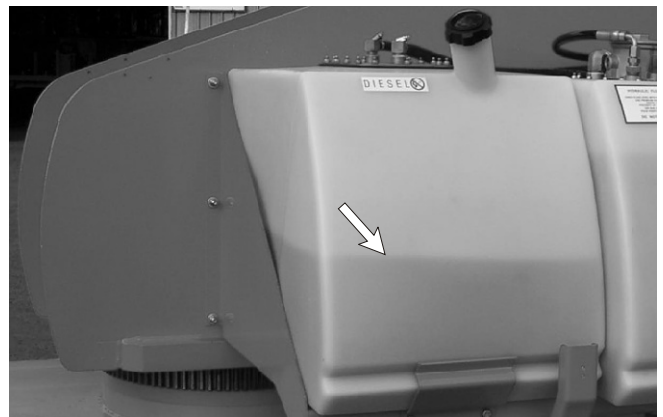

Figure 4.4—Diesel Fuel Gauge

NOTE

Do not run a diesel fuel tank empty. Air in the fuel line makes the engine hard to start.

■ Engine Oil

The engine oil level is measured with a dipstick. Oil sump and filter capacities in the engine specification charts are approximate. The dipstick is the only way to accurately determine the engine oil level. The engine oil level should always be in the cross-hatched area of the dipstick.

The dipstick on a Deutz engine is located behind the door on the right side of the turntable (refer to Figure 4.5).

Chapter 4. Gauges and Displays

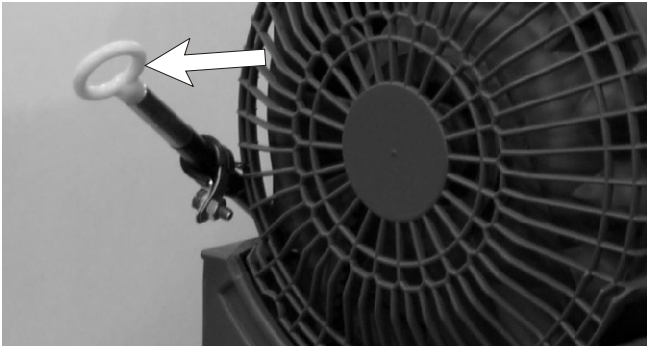

Figure 4.5—Deutz Engine Dipstick

The dipstick on a Cummins engine is located behind the door on the right side of the turntable (refer to Figure 4.6).

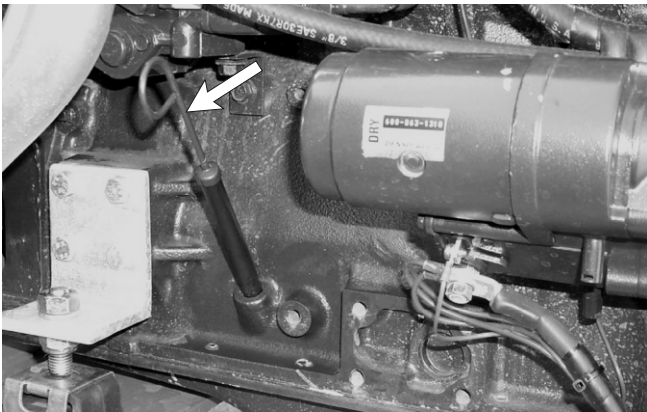

Figure 4.6—Deutz Engine Dipstick

■ Hydraulic Fluid Filter Gauge

The fluid filter gauge (refer to Figure 4.7) is located next to the filter under the cover on the left side of the turntable. The gauge indicates the condition of the filter. When the needle on the gauge is in the red zone, it is time to change the filter.

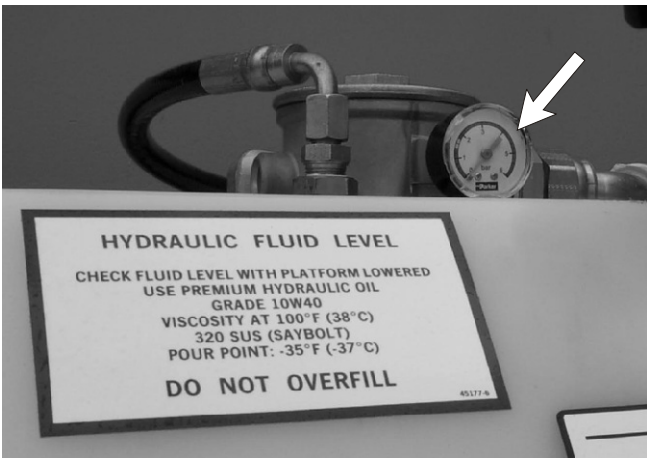

Figure 4.7—Fluid Filter Gauge

■ Tilt Sensor Indicator

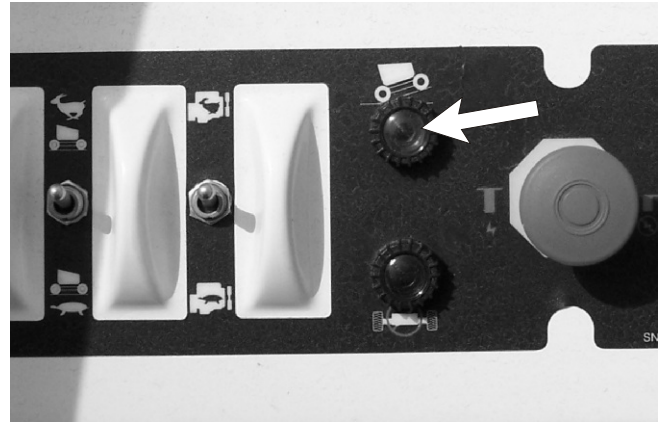

Figure 4.8—Tilt Sensor Indicator

This lamp will illuminate (see Figure 4.8) when the SP has reached the maximum angle of tilt. In addition an alarm will sound.

▲ IMPORTANT

It is important to be aware that this is a visual/aural indication only. There are no corresponding automatic engine 'shut down' or control lockout procedures.

■ Automatic Shut-offs

□ Engine temperature (Cummins engine)

There is a temperature sensor in the engine. It measures the temperature of the antifreeze-water mixture as the mixture leaves the top of the radiator and enters the top of the engine.

If the temperature reaches 210°F (99°C) an alarm sounds. If the temperature continues to rise, the engine shuts off when the temperature reaches 230°F (110°C).

The engine will not restart until the temperature drops below 210°F (99°C).

□ Engine temperature (Deutz engine)

The Deutz engine is air cooled therefore it is the oil temperature that is monitored.

Should the engine oil temperature exceed 130° C the engine will shut down automatically.

It will restart but will be shut down again unless the oil temperature returns to normal.

□ Engine oil pressure

There is an oil pressure sensor in the engine. It measures the engine oil pressure at the oil filter.

If the pressure falls below a safe operating value the engine shuts off.

The engine will restart with low pressure but it will only run a few seconds before it automatically shuts off again.

□ Dynamic brakes

When you drive an SP down a slope, if the SP begins to coast (outrun the drive motors) the hydraulic system “senses” the coasting condition.

The hydraulic drive motors then become hydraulic brakes and the SP is slowed. This action prevents SP’s from speeding down grades.

□ Platform height vs. drive speed

When the platform is raised above horizontal the drive speed is limited to its slowest speed and the engine revs are also automatically lowered.

□ Axle lockout

The articulating axle will automatically “lock” when the boom is extended beyond 50% and the column is slewed out over the side of the base. There is a warning light in the platform control box (Refer to Figure 5.1 and 5.2) that indicates when the axle is in the locked position.

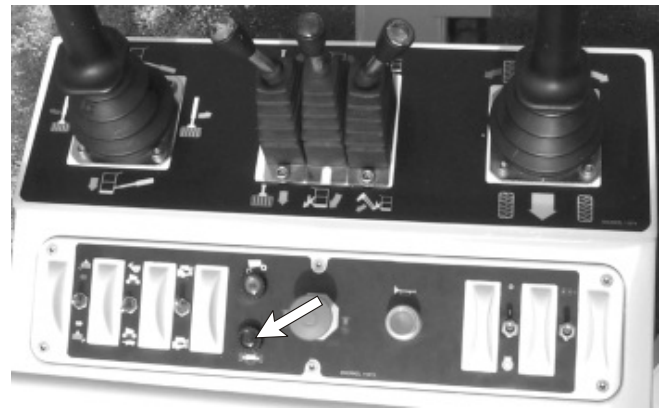

Figure 5.1—Axle Lockout Indicator Light (Hydraulic Controls)

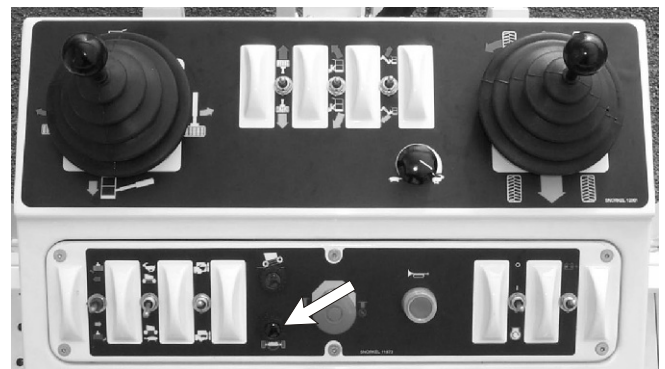

Figure 5.2—Axle Lockout Indicator Light (Electric Controls)

■ Circuit Breakers

□ Main circuit breakers

There are three circuit breakers, on the SP. These are located inside the lower control box (Refer to Figure 5.3). Their purpose is to protect the electrical circuits from electrical overloads. When a circuit breaker trips (pops out) push it back in then attempt to use the SP.

If the circuit breaker trips a second time, take the SP out of service and refer the problem to a qualified trained service technician for repair.

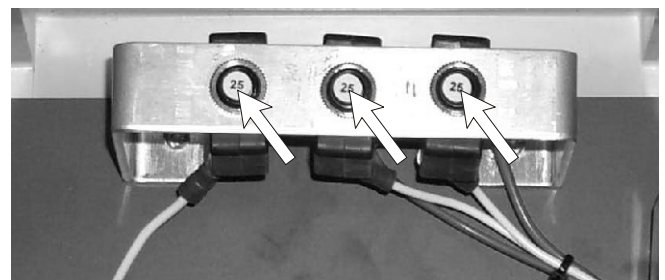

Figure 5.3—Circuit Breakers

Chapter 5. Shut-offs and Circuit Breakers

□ RCD / ELCB

The RCD (Residual Current Device) is located at the ground and will protect against short circuits to earth (Refer to Figure 5.4). When there is a short circuit the RCD will shut down the 230v AC power to the platform outlet.

To reset the outlet disconnect the power tool lead from the platform box and reset the RCD at the ground.

If the problem persists call a trained service technician.

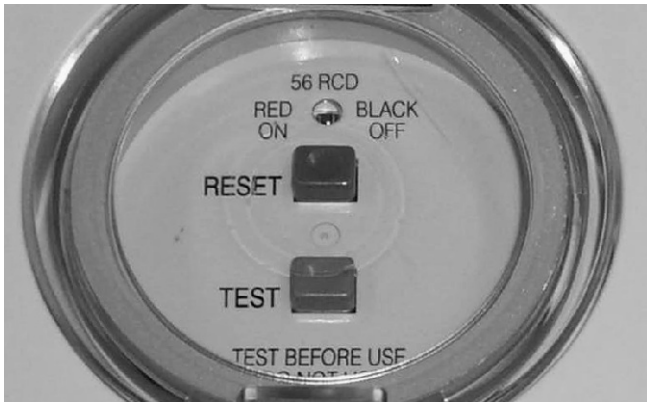

Figure 5.4—RCD / ELCB

Controls to position the platform and drive the SP are located on the lower control panel on the turntable and on the upper control panel in the platform.

This chapter explains what each control does. This chapter DOES NOT explain how to use the controls to produce useful work, refer to the 'Operation' chapter for that.

See the 'Emergency Operation' chapter for emergency operation procedures.

■ Chassis Controls

□ Battery Disconnect Switch

The battery disconnect switch is located under the cover on the right side of the turntable (refer to Figure 5.1)

The battery disconnect removes electrical power from all electrically controlled functions when in the off position. Place the switch in the on position to operate any electrically controlled function.

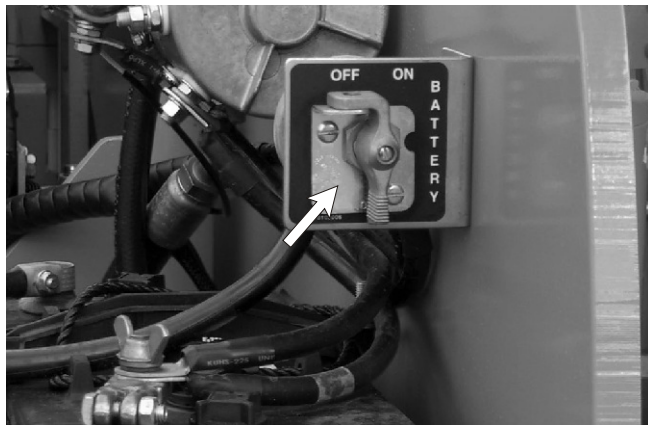

Figure 5.1—Battery Disconnect Switch

⚠ CAUTION

Only authorized personnel should operate the aerial platform. Unqualified personnel may cause injury to coworkers or property damage. Lock the battery disconnect switch in the off position before leaving the aerial platform unattended.

Lock the battery disconnect switch in the off position to prevent unauthorized use of the aerial platform.

■ Ground Controls

The lower controls (refer to Figure 5.2 and 5.3) are located on the right side of the turntable.

□ Ground controls

- Emergency stop switch
- Master key switch
- Ground / platform selector switch
- Emergency power switch
- Manual control levers

1. **Master Key Switch:** This works like an automobile ignition switch. Hold it at start until the engine starts, then release it to on. If the engine 'dies' during this starting process, the key must be turned to off before it will go back to the start position.
2. **Emergency Stop Switch:** Press the red EMERGENCY STOP switch in at any time, under any conditions, and the entire machine stops, and nothing moves. This switch must be on (out) for anything on the SP to work. Pull the switch and it will pop out (on).
3. **Ground/Platform Selector Switch:** Must be in the GROUND position for the ground controls to work and in the PLATFORM position (up) for the platform controls to work.
4. **Emergency Power Switch:** Press the EMERGENCY POWER switch down to operate the SP platform functions using the emergency power system.

Note - Emergency Power System

The emergency power system is for lowering the platform during an emergency and is not intended for normal machine operation.

5. **Manual Control Levers:** The levers control all functions from the ground control station. Each lever is clearly marked with symbols indicating its function (see Figure 5.3 for a description of the specific function for each control lever).

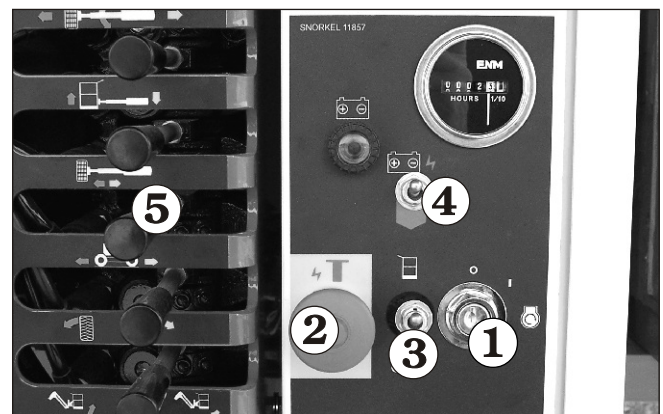

Figure 5.2—Ground Controls

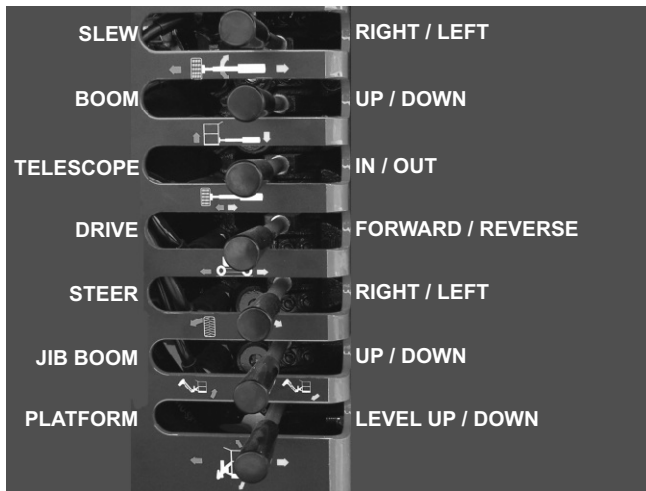

Figure 5.3—Ground Control Levers

⚠ WARNING

Extreme care must be exercised if driving the SP from the ground controls.

The position of the operator will preclude seeing if other people or obstacles are at the other side of the machine.

This exercise should not be undertaken without support personnel providing visual assistance.

Additionally great care must be taken to ensure that the machine rear wheels do not run over the operator.

■ Platform Controls - Electric Controls

The upper controls (refer to Figure 5.4 and 5.5) are located on the control box at the platform. Boom, platform, and drive functions can be operated from the upper controls. The following controls are located on the upper control panel.

□ Platform controls - electric controls

- Emergency stop button
- Start / Stop switch
- Boom and platform joystick
- Drive and steer joystick
- High range switch
- Horn button
- Emergency power switch
- High revs switch
- Platform rotate
- Boom extend / retract
- Platform level
- Jib boom - SP18 only

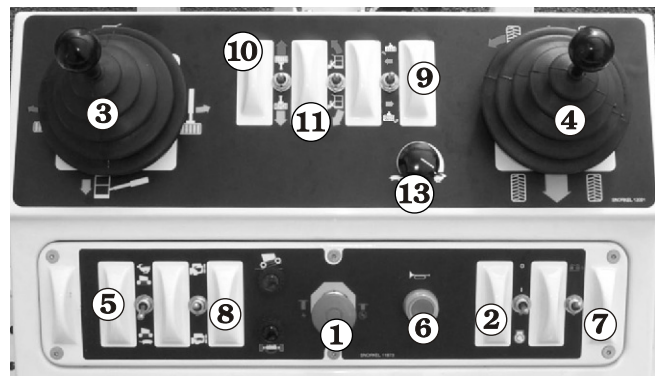

Figure 5.4—Platform Controls, SP17 (Electric Controls)

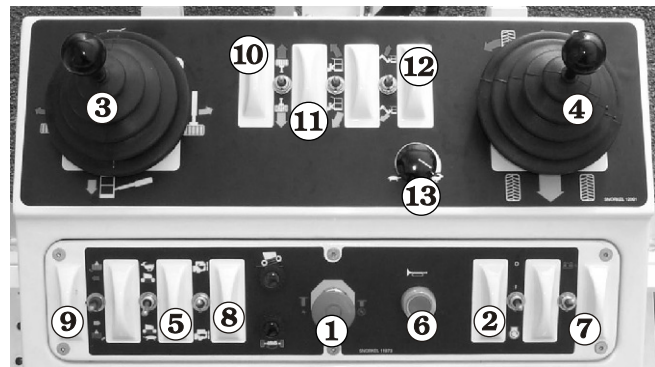

Figure 5.5— Platform Controls, SP18 (Electric Controls)

1. **Emergency Stop Switch:** Press the red EMERGENCY STOP switch in, at any time, under any conditions, and the entire machine stops, and nothing moves. The switch must be on (out) for anything on the SP to work. Pull the switch and it will pop out (on).
2. **Start / Stop Switch:** this switch functions as the IGNITION switch. Move it to the first position and the power is switched on, pull it fully forwards and hold it to start the engine. To turn the engine off switch it to the rear-most position.
3. **Boom and Platform Joystick:** The available movement functions of the joystick are clearly indicated with symbols around the base. Movement of the joystick in a given direction (left, right, up, down) produces a corresponding movement of the platform and booms.
4. **Drive and Steer Joystick:** The drive and steer joystick (refer to Figures 5.4 and 5.5) controls drive forward and reverse, and steer right and left. The steering and drive functions may be operated simultaneously.

Note - Steering

The steering wheels are not self-centering. Set the steering wheels straight ahead after completing a turn.

5. **High Range Switch:** Lets the operator select between low speed and high torque (down) and high speed and low torque (up).
6. **Horn Button:** Press the push-button to sound the horn and alert others.
7. **Emergency Power Switch:** Operate the emergency power switch to access the aerial platform functions using the emergency power system.

Note - Emergency Power

The emergency power system is for lowering the platform during an emergency and is not intended for normal machine operations.

8. **High Revs Switch:** Use this switch to increase the 'revs' and torque of the machine.
9. **Platform Rotate Switch:** Press this switch up or down to rotate the platform to the right or left. This switch is located in different positions on the SP20 and the SP22.
10. **Boom Telescope Switch:** Push this switch forward to telescope (extend) the boom out and pull it back to telescope (retract) the boom in.
11. **Platform Tilt Switch:** Push this switch forward to tilt the platform upwards and pull it back to tile the platform downwards.
12. **Jib Boom Switch:** Push this switch forwards to extend the jib boom and pull it back to retract the jib boom.

Note - Jib Boom

The jib boom is only available on the SP22.

13. **Speed Control:** The speed of the functions may be varied using this control.

Note - Controls Override

The lower controls override the upper controls. If the upper control emergency stop button is engaged the lower controls can still be used to operate the aerial platform.

■ Platform Controls - Hydraulic Controls

The upper controls (refer to Figure 5.6 and 5.7) are located on the control box at the platform. Boom, platform, and drive functions can be operated from

the upper controls. The following controls are located on the upper control panel.

□ Platform controls - hydraulic controls

- Emergency stop button
- Start switch
- Boom and platform joysticks
- Drive and steer joystick
- High range switch
- Horn button
- Emergency power switch
- High revs switch
- Platform rotate switch - **SP22 only**
- Platform rotate joystick - **SP20 only**
- Platform tilt joystick
- Boom telescope (extend/retract) joystick
- Jib boom joystick - **SP22 only**

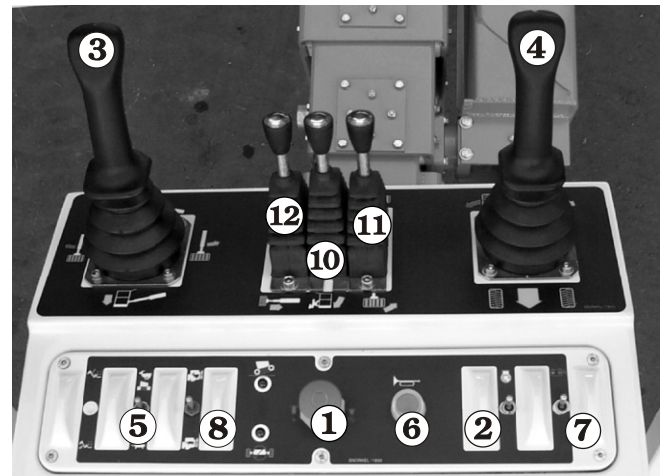

Figure 5.6—Platform Controls, SP17 (Hydraulic Controls)

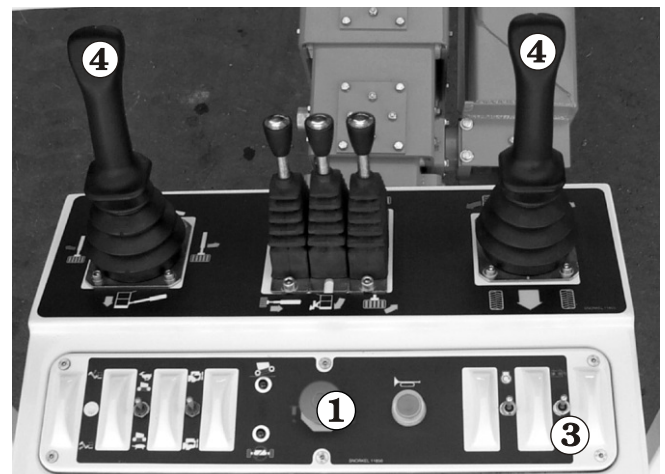

Figure 5.7— Platform Controls, SP18 (Hydraulic Controls)

Chapter 6. Controls

1. **Emergency Stop Switch:** Press the red EMERGENCY STOP switch in, at any time, under any conditions, and the entire machine stops, and nothing moves. This switch must be on (out) for anything on the platform of the SP to work. Pull the switch and it will pop out (on).
2. **Start / Stop Switch:** This switch functions as the IGNITION switch. Move it to the first position and the power is switched on, pull it fully forwards and hold it to start the engine. To turn the engine off switch it to the rear-most position.
3. **Boom and Platform Joystick:** The available movement functions of the joystick are clearly indicated with symbols around the base. Movement of the joystick in a given direction (left, right, up, down) produces a corresponding movement of the platform and the booms.
4. **Drive and Steer Joystick:** The drive and steer joystick controls drive forward and reverse, steer right and left. The steering and drive functions may be operated simultaneously.

Note - Steering

The steering wheels are not self-centering. Set the steering wheels straight ahead after completing a turn.

5. **High Range Switch:** Lets the operator select between low speed and high torque (down), and high speed and low torque (up).
6. **Horn Button:** Press the push-button to sound the horn and alert others.
7. **Emergency Power Switch:** Operate the emergency power switch to access the aerial platform functions using the emergency power system.

Note - Emergency Power

The emergency power system is for lowering the platform during an emergency and is not intended for normal machine operations.

8. **High Revs Switch:** Use this switch to increase the 'revs' and torque of the machine.
9. **Platform Rotate Switch: (SP22 only)** Press this switch up or down to rotate the platform to the right or left.
10. **Platform Rotate Joystick: (SP20 only)** Operate this control to rotate the platform to the right or left.

11. **Platform Tilt Joystick:** Operate this control to tilt the platform up or down.
12. **Boom Telescope Joystick:** Pull the joystick back to telescope the boom out (extend) or push it forwards to telescope the boom in (retract).
13. **Jib Boom Joystick: (SP22 only)** Push the joystick forwards to extend the jib boom and pull it back to retract the jib boom.

Note - Controls Override

The lower controls override the upper controls. If the upper control emergency stop button is engaged the lower controls can still be used to operate the aerial platform.

■ Platform Foot Switch

The upper controls are interlocked through the platform foot switch (refer to Figure 5.8). Step down on and hold the platform foot switch to activate the drive and boom functions from the upper controls.

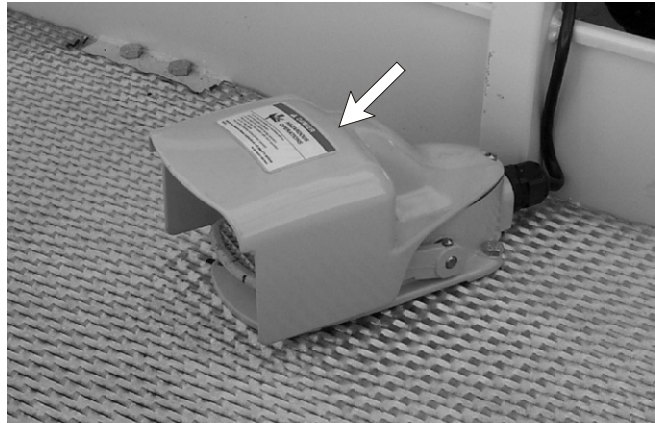

Figure 5.8—Platform Foot Switch

■ AC Generator (Optional)

The control for the generator is located on the upper control panel.

Place the switch in the generator position to provide electrical power to the two electrical outlets at the platform and to the outlet on the end of the generator housing.

Machine functions will not operate while the switch is in the generator position.

Chapter 7. Pre-operational Inspection

Potential service and safety problems may be detected by inspecting the aerial platform every day (or 8 hour shift).

This chapter includes a Pre-operational Inspection table (refer to Figure 6.1) and information on properly inspecting each item listed in the table.

The purpose of the Pre-operational Inspection is to keep the SP in proper working condition and to detect signs of malfunction at the earliest possible time.

Perform the inspection at the beginning of each shift before using the aerial platform on the job.

The inspection site must have a smooth and level surface. Use the Pre-operational Inspection table to ensure no areas are overlooked.

Set the Key Switch to OFF before you begin this inspection.

▲ DANGER

The potential for an accident increases when operating an aerial platform that is damaged or malfunctioning.

Death or serious injury can result from such accidents.

Do not operate the aerial platform if it is damaged or malfunctioning.

Repair all equipment damage or malfunctions before placing the SP into service.

Item	Inspect for
Operator's manual	In manual holder
Engine Oil level Coolant Fuel tank Fuel line Air filter Charging system	Between full and add marks Liquid cooled engines-proper fluid level Air cooled engines-air intake and fan free of obstructions. Belt in good condition Tank full, cap in place and tight No leaks Yellow disk in the green zone Proper operation
Electrical system Battery fluid level Battery terminals Cables and wiring harness	Proper level Clean, connectors tight No wear or physical damage
Hydraulic system Fluid level Fluid filter Hoses, tubes, and fittings	Between full and add marks Verify operation in the green or yellow zone No leaks
Tires and wheels Foam filled	Good condition
Lower control station Operating controls Emergency stop Emergency power	Proper operation Shuts off lower controls Proper operation
Emergency lowering	Proper operation
Level sensor	Sounds tilt alarm
Flashing light	Proper operation
Hostile environment kit	In place and proper operation
Sound suppression kit	In place and proper operation
Structures Weldment Slide pads Fasteners Wire ropes	Welds intact, no damage or deformation In place, no damage or deformation In place and tight Proper position and tension

Chapter 7. Pre-operational Inspection

Item	Inspect for
Upper control station	No damage or deformation
Guardrail system	No damage or deformation
Lanyard anchors	Proper operation
Operating controls	Shuts off upper controls
Emergency stop	Proper operation
Emergency power	Sounds when activated
Horn	Proper operation
Electrical power outlet	Proper operation
Air line	Sounds when aerial platform moves
Drive motion alarm	Proper operation
Driving and work lights	In place and proper operation
Platform control cover	
Placards and decals	In place and readable

Figure 6.1—Pre-operational Inspection Table

■ Operator's Manual

The operators manual is located in the locker on the base of the SP.

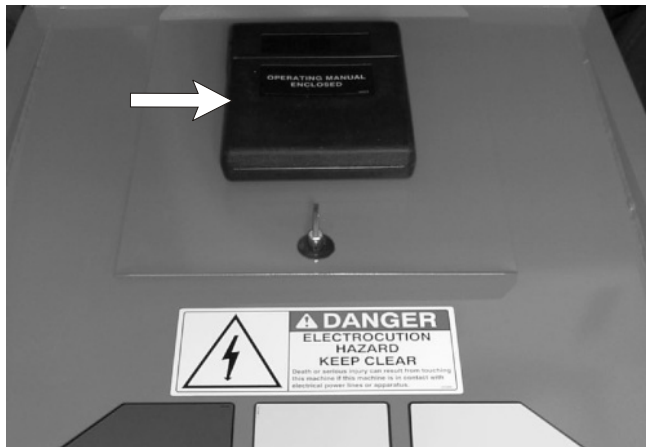

Figure 6.2—Operator's Manual Holder

Check to see that the proper Operator's manual is with the aerial platform. The manual should be complete with all pages intact and in readable condition.

■ Engine

☐ Oil Level

Check the engine oil level before starting the engine so the oil has drained to the pan. The proper oil level is between the marks on the dipstick (refer to Figures 6.3 and 6.4 for dipstick locations).

Add oil, if necessary, before starting the engine.

Ensure that the correct grade and viscosity of oil is added. Refer to the Specifications Chapter for this information.

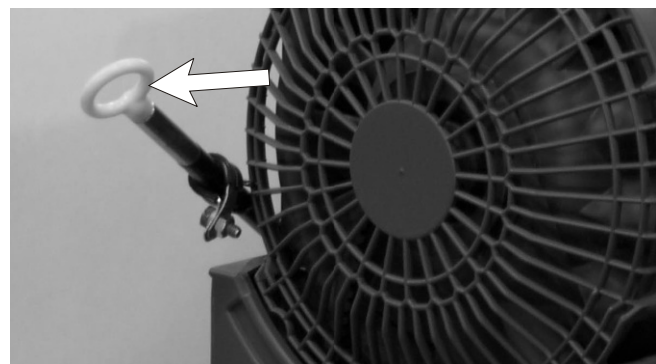

Figure 6.3—Deutz Engine Dipstick

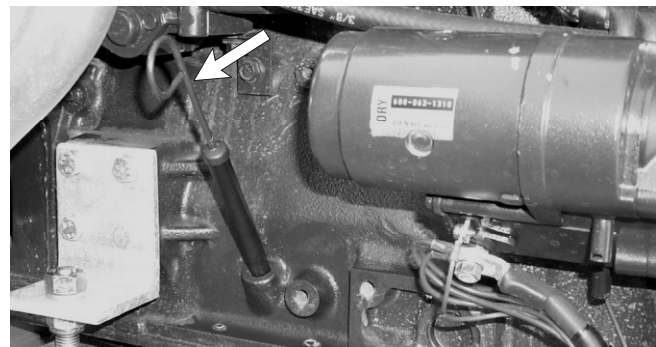

Figure 6.4—Cummins Engine Dipstick

☐ Cooling

Deutz engines are oil/air cooled. Visually inspect the air intake and fan (refer to Figure 6.5) to be sure they are free of obstructions that could stop or slow the flow of air. Inspect the fan belt to see that it is in place and not cracked.

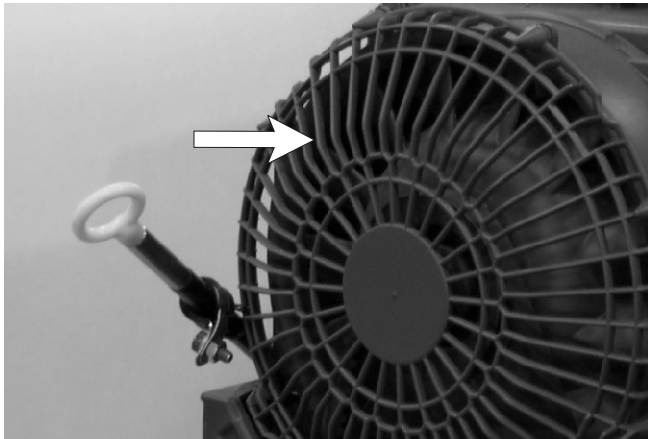

Figure 6.5—Deutz Air Intake

The Cummins engine is liquid cooled (see Figure 6.6) with a radiator and overflow reservoir.

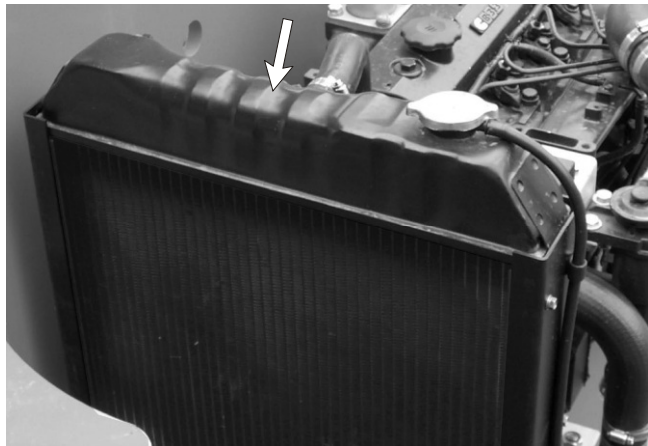

Figure 6.6—Cummins Radiator

Add coolant, if necessary, when the engine is cold and not running. When running at operating temperature the coolant in the reservoir bottle should be at the 'hot' level.

⚠ CAUTION

Engine coolant escaping under pressure can cause serious burns. Shut the engine off and let it cool before removing the radiator cap.

☐ Fuel Tank

Check the fuel level (refer to Figure 6.7) and add fuel if necessary. Make sure the cap is securely fastened.

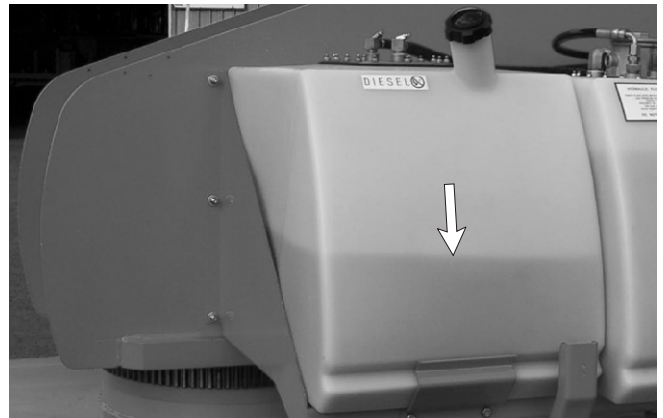

Figure 6.7—Diesel Tank

☐ Fuel Line

Visually inspect the entire length of the fuel line. Start at the fuel tank and trace the line (refer to Figure 6.8) to the engine inspecting for leaks and damage.

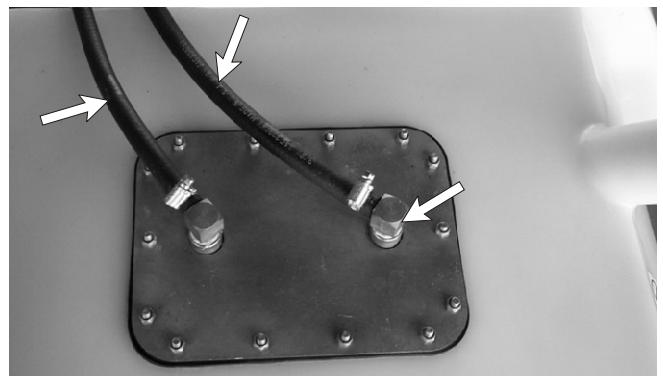

Figure 6.8—Fuel Line

☐ Air Filter

The air filter gauge (refer to Figure 6.9) has a yellow disk in it that rises toward the red zone as the filter clogs.



Figure 6.9—Air Filter

Chapter 7. Pre-operational Inspection

To inspect the air filter:

1. Turn the battery disconnect switch on and close the cowling door.
2. At the lower controls, set the emergency stop switch on.
3. Insert the key into the master switch and turn the engine on.
4. Check the yellow disk after running the engine for 30 seconds.
 - If the yellow disk is in the red zone replace the filter.
 - If the yellow disk is in the green zone the filter is OK.
5. Shut off the engine.

■ Electrical System

Electrical power is supplied from a 335 amp/hour, 12 volt battery. This battery supplies 12 volt DC electrical power to operate the aerial platform electrical and electro hydraulic components.

▲ DANGER

Batteries give off hydrogen and oxygen that can combine explosively. Death or serious injury can result from a chemical explosion. Do not smoke or permit open flames or sparks when checking the batteries.

▲ DANGER

Even with low voltage electrical systems, severe arcing can occur. Electrical shock or component damage can result from contact with energized conductors. Use caution when working with any electrical device.

The battery is under the cover on the right side of the turntable.

□ Battery Fluid Level

Remove the caps from the battery. Visually check the battery fluid level. If the level is not within (6 mm) of the bottom of the filler neck inside each hole, add distilled water. Replace the caps on the battery. The caps must be in place and tight during machine operation. (It is possible that your machine may be fitted with a maintenance free battery.)

□ Battery Terminals

Check the battery terminals and cable ends. They should be clean and free of corrosion and dirt. If necessary, clean the terminals and cable ends with a wire brush or terminal cleaning tool. All cable ends must be securely fastened to the terminals.

□ Cables and Wiring Harness

Inspect all cables and wiring for wear and/or physical damage such as loose connections, broken wires, and frayed insulation. Check the wiring in areas where a change in routing direction may cause them to become pinched (refer to Figure 6.10). Make sure the cables and wires are properly routed to avoid sharp edges, pinching, and scuffing.

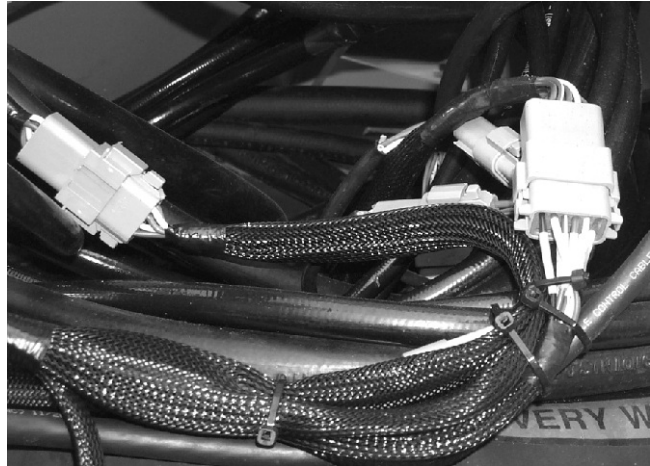

Figure 6.10—Cables and Wiring Harness

■ Hydraulic System

Hydraulic power is supplied from an engine driven variable displacement piston pump.

▲ DANGER

Hydraulic fluid escaping under pressure can have enough force to inject fluid into the flesh. Serious infection or reaction can result if medical treatment is not given immediately. In case of injury by escaping hydraulic fluid, seek medical attention at once. Do not search for leaks with your hand. Have a qualified trained maintenance person repair all hydraulic fluid leaks before you operate an SP.

The hydraulic reservoir is behind the door on the left side of the turntable.

□ Fluid Level

Check the hydraulic reservoir fluid level with the aerial platform stowed on a level surface. The fluid level must be between the full and add marks as viewed on the reservoir panel (refer to Figure 6.11).

If necessary, remove the filler cap and add fluid of the proper type. Refer to Chapter 2 for the proper type and grade of hydraulic fluid to use. The need to regularly add fluid indicates a leak that should be corrected.

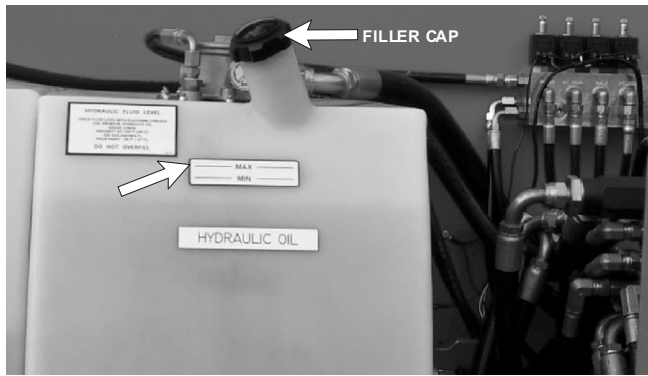

Figure 6.11—Fluid Level Indicator

▲ CAUTION

Not all hydraulic fluid is suitable to use in the hydraulic system. Some have poor lubricating characteristics and can increase component wear. Only use hydraulic fluid as recommended.

☐ Fluid Filter

Checking the condition of the hydraulic fluid filter is part of the machine maintenance schedule and should not be performed by the operator.

☐ Hoses, Tubes, and Fittings

Inspect all hydraulic hoses, tubes, and fittings for wear, leakage, or damage (refer to Figure 6.12). Make sure the hoses are properly routed to avoid sharp edges, kinking, and scuffing. Inspect the tubes for dents or other damage that may restrict fluid flow. Make sure all hoses and tubes are held firmly in their support brackets.

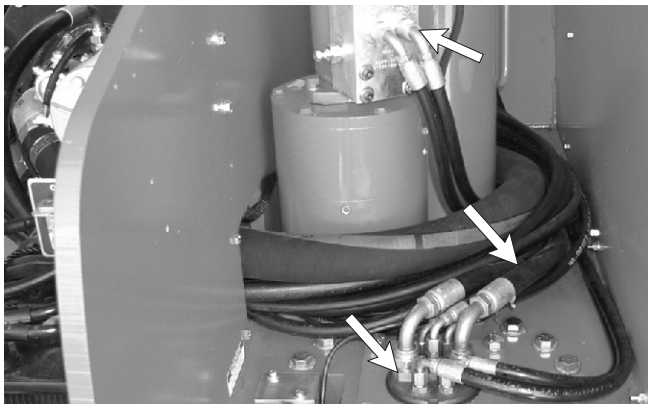

Figure 6.12—Hose, Tubes, and Fittings

Hydraulic fluid leaks are easily visible on the ground. Check under the chassis for fluid that has leaked. Hydraulic oil leaks are easily visible and can show up anywhere. Carefully inspect the ends of the booms. Oil can run down inside of the booms and drip out the end.

■ Tires and Wheels

Visually inspect the tires and wheels to make sure they are suitable for service. Check the wheel lug nuts to see that none are missing, damaged, or loose. This aerial platform has foam filled tires. Different types of tires have different inspection requirements.

☐ Foam Filled

Inspect for large holes or cuts where foam is coming out of the tire. Look for large imbedded objects, such as angle iron, that can rip a tire open. Punctures caused by bolts, screws, or nails are not a problem for foam filled tires.

■ Ground Control Station

With no personnel in the platform, test the operation of each control from the ground controls (refer to Figure 6.14).

Before starting the test place the battery disconnect switch in the on position (see Figure 6.13)

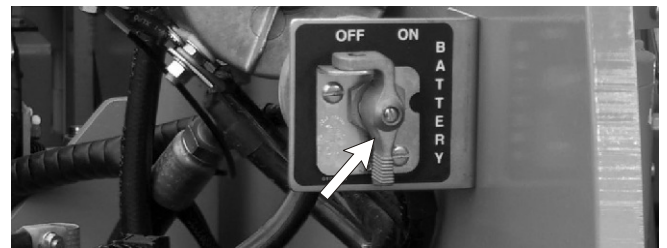

Figure 6.13—Battery Disconnect Switch

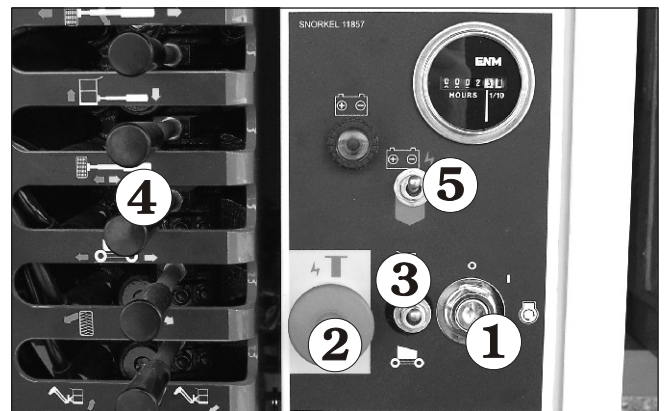

Figure 6.14—Ground Controls

☐ Operating Controls

Start the engine **1** and pull the emergency stop button out **2**. Select 'ground' operation (down) with switch **3** to operate the aerial platform from the lower controls **4**.

Test the operation of each function in both directions.

Chapter 7. Pre-operational Inspection

NOTE

The SP17 does not have a jib boom.

▲ DANGER

Pinch points may exist between moving components. Death or serious injury can result from becoming trapped between components, buildings, structures, or other obstacles. Make sure all personnel stand clear of the aerial platform while performing the daily inspection.

When checking the turntable rotation function in the clockwise direction, the turntable will rotate toward you.

☐ Emergency Stop

Push the emergency stop button **2** in to turn off the engine. The lower control functions should not operate with the emergency stop in this position.

☐ Emergency Power

Place the battery disconnect switch in the on position and pull the emergency stop button **2** out to turn on the electrical power. Press and hold the ground operation button and operate the emergency **5** power switch to operate the aerial platform from the lower controls using the emergency power system.

☐ Emergency Lowering

The main boom can be lowered in an emergency using the emergency lowering valve. The emergency lowering valve is at the base of the control panel (refer to Figure 6.15).



Figure 6.15—Emergency Lowering Knob

Use the following procedure to test the emergency lowering system.

1. Use the lower controls to raise the main boom approximately 1FT (0.3 m).

2. Push the emergency stop button in.
3. Stand clear of the booms and slowly turn the knob to open the bleed down valve. The boom should slowly lower by gravity. Control the rate of descent by turning the valve.

▲ DANGER

The potential for an accident increases when safety devices do not function properly. Death or serious injury can result from such accidents. Fully close the emergency lowering knob before operating the aerial platform.

4. Turn the valve to close the cylinder bleed down valve.

■ Level Sensor

Use the following procedure to test the level sensor.

1. Position the aerial platform on a smooth, flat, level surface.
2. Remove all persons and materials from the platform.
3. Open the door on the lower control box to access the level sensor (refer to Figure 6.16).

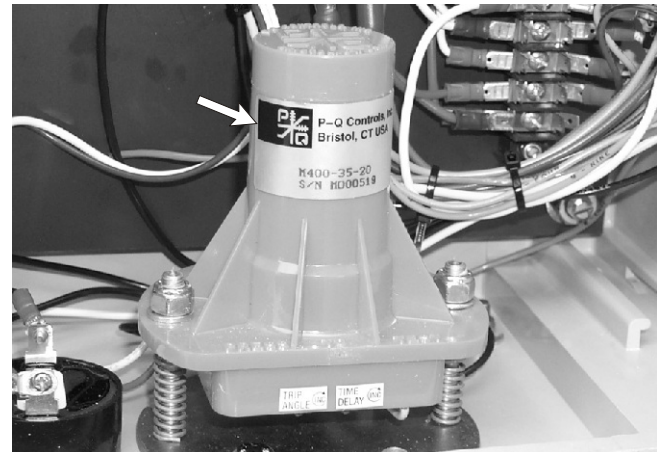

Figure 6.16—Level Sensor

4. Start the engine.
5. Extend the main boom about 5FT to 10' (2 to 3 m).
6. Pull the level sensor to the side as far as possible to activate the tilt alarm.

▲ DANGER

The potential for an accident increases when safety devices do not function properly. Death or serious injury can result from such accidents. Do not alter, disable, or override any safety device.

7. If the alarm does not sound, remove the machine from service until the problem is corrected.
8. Retract the main boom.

■ Flashing Lights

Visually check to see that they flash. The lights should flash when the machine is set up for operation from the lower or upper controls.

■ Hostile Environment Kit (Option)

The optional Hostile environment kit helps protect the cylinders from abrasion while sandblasting or from paint overspray. Covers protect each cylinder rod as it extends and retracts. The covers prevent sand and paint from damaging the cylinder seals and rod.

Inspect the covers while operating the machine to ensure they are securely fastened and completely cover the cylinder rod.

■ Structures

Visually inspect all weldments and related components. It is important to inspect the fasteners that connect the components. This inspection is intended to provide a 'snapshot' of the machines structural condition and highlight any obvious defects such as a cracked weld or missing bolts.

□ Weldments

Visually inspect all weldments for abnormal wear, abrasion, or deformation that could cause interference between moving parts.

Inspect the welds on the structural components. Pay particular attention to boom welds. The area to be inspected should be clean and free of dirt and grease.

Look for visible cracks in the weld and at the weld to parent material joint. A bright light may be used to provide adequate visibility of the inspection area.

□ Slide Pads

The main boom has slide pads (refer to Figure 6.17) between the base, intermediate and tip boom sections.

Use the lower controls to raise and extend the main boom about 10' (3 m). Visually inspect the slide pads to make sure they are in place.

Inspect the surface where the pads contact the intermediate and tip booms. The paint must be in place with no signs of bare metal.

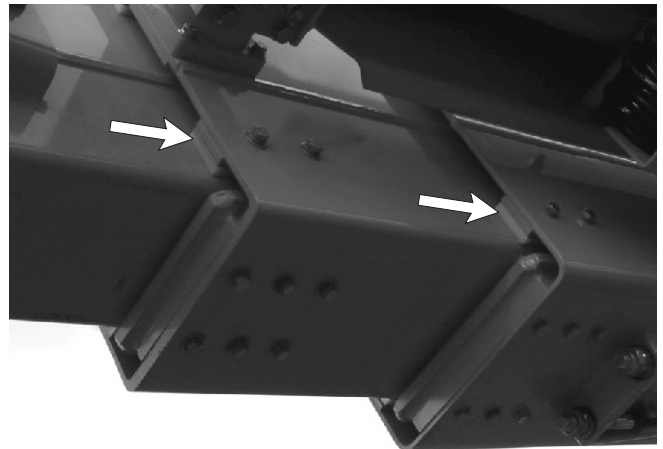

Figure 6.17—Slide Pads

□ Fasteners

Visually inspect all fasteners to see that none are missing or loose.

Pay particular attention to all of the bolts, nuts, rollpins, collars, and snap rings that connect the booms and cylinders. They should all be present, tight, and not damaged in any way.

Raise the main boom to access the rotation bearing bolts in the turntable (refer to Figure 6.18).

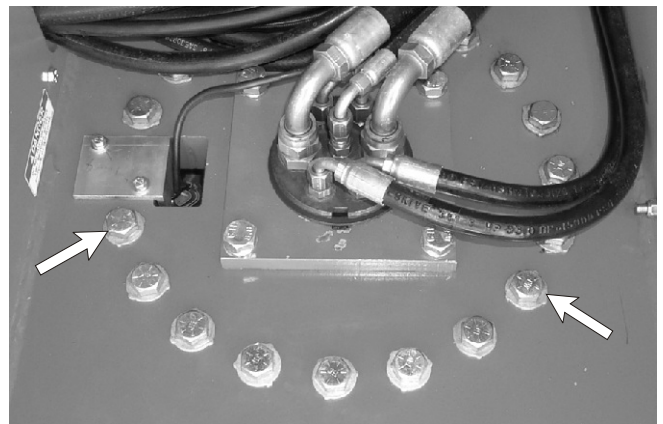

Figure 6.18—Rotation Bearing Bolts

Inspect the rotation bearing bolts to ensure that none are missing, damaged, or loose.

□ Wire Ropes

There is a wire rope connection (refer to Figure 6.19) on the top and bottom of the main boom. Visually inspect both connections.

The wire ropes near the outside the boom should not have any broken strands or be distorted in any way.

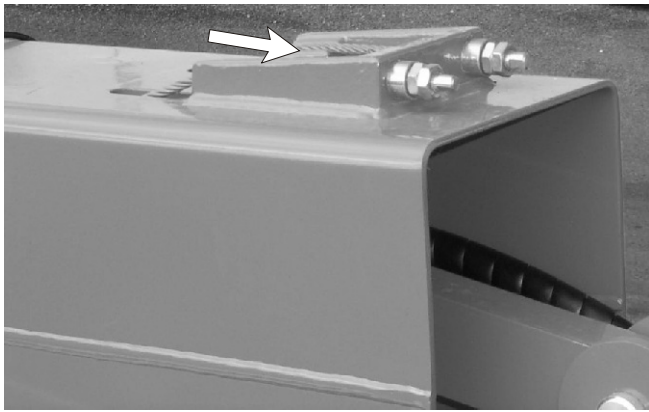

Figure 6.19—Wire Ropes

■ Platform Control Station

Inspect the platform and upper controls only if all functions operated properly from the lower controls.

□ Guardrail System

The guardrail system (refer to Figure 6.20) includes the top rail, mid rail, toeboards and a gravity gate or optional swingin gate.

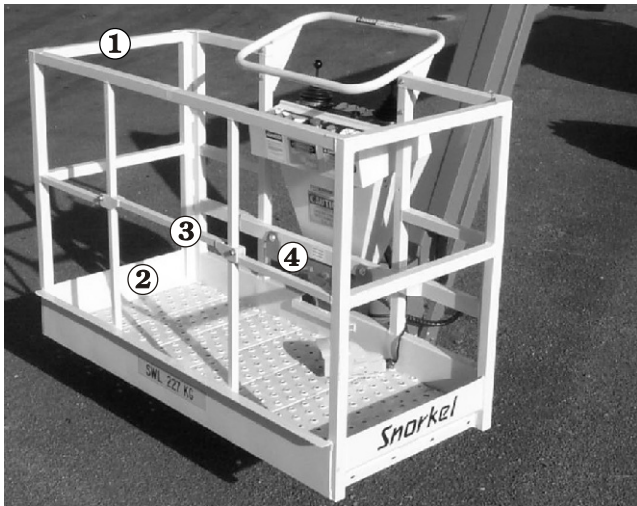

Figure 6.20—Guardrail System

Inspect all components of the guardrail system. The rails ① and toeboards ② must all be in place and free of any damage or deformation. Visually check the rail and toeboard welds for cracks. All bolts and nuts fastening the guardrails in place must be present and not show any signs of looseness.

Inspect the gravity gate ③ to be sure it is present, is not damaged, and moves freely.

□ Lanyard Anchors

There are two lanyard anchors ④ below the upper control panel (refer to Figure 6.18). Visually inspect the lanyard anchors to make sure they are in place, are not deformed and are securely fastened to the platform.

■ Platform Control Station Operating Controls (Electric Controls)

Place the battery disconnect switch in the on position (see Figure 6.21) and pull the emergency stop button out on the lower control panel.

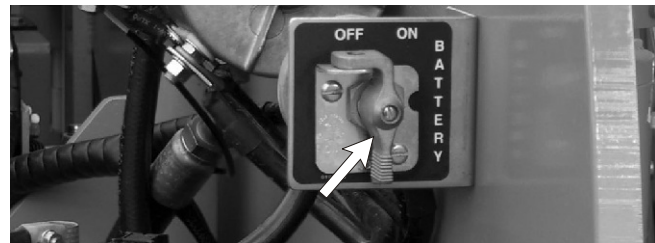

Figure 6.21—Battery Disconnect Switch

□ Foot switch

From the upper controls, test the platform foot switch by selecting a boom function and moving the boom joystick without stepping on the foot switch. If movement occurs the interlock is not functioning properly. Do not operate the machine until the problem is corrected.



Figure 6.22—Platform Foot Switch

□ Movement controls

Test the operation of each control in both directions from the upper controls (refer to Figures 6.23 and 6.24).

Note

The SP17 does not have a jib boom.

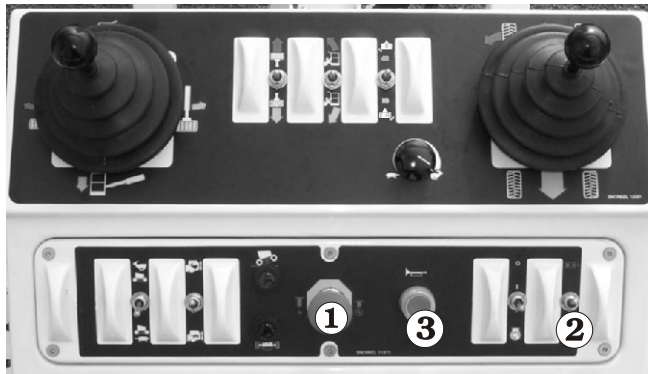

Figure 6.23—Platform Controls SP17 (Electric Controls)

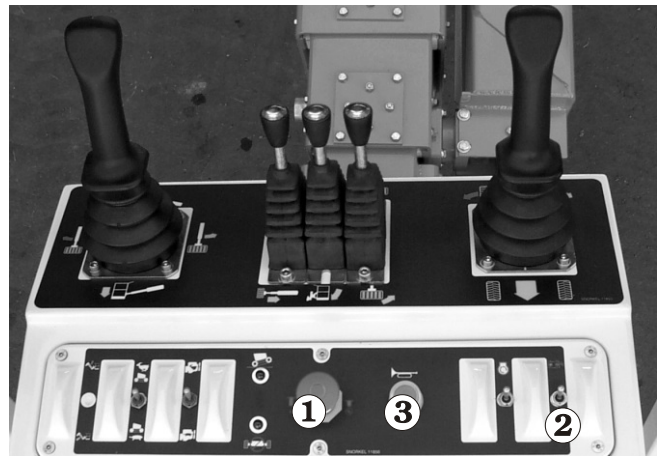

Figure 6.25—Platform Controls SP17 (Hydraulic Controls)

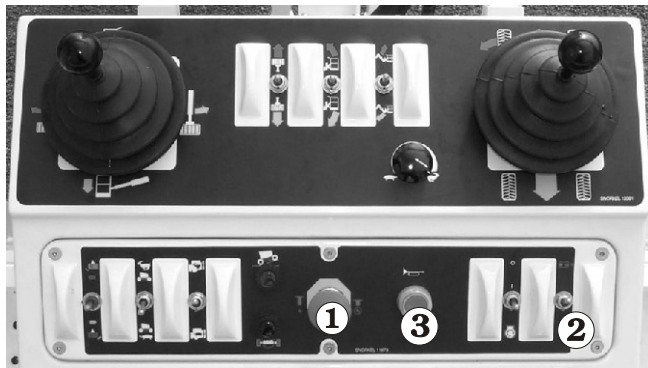

Figure 6.24—Platform Controls SP18 (Electric Controls)

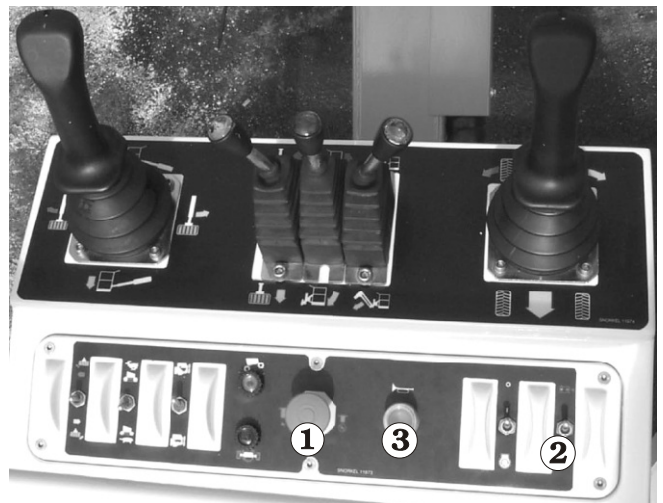

Figure 6.26—Platform Controls SP18 (Hydraulic Controls)

Emergency Stop

Push the red emergency stop button **1** in to turn off the engine. The upper control functions should not operate with the emergency stop in this position.

Emergency Power

Place the battery disconnect switch in the on position (see Figure 6.19) and pull the emergency stop button **1** out to turn on the electrical power. Operate the emergency power switch **2** to operate the aerial platform from the upper controls using the emergency power system.

Horn

Depress the horn button **3** on the right side of the upper control panel to ensure that it sounds to warn personnel in the area.

Operating Controls - Hydraulic Controls

Place the battery disconnect switch in the on position (see Figure 6.21) and pull the emergency stop button out on the lower control panel.

Foot switch

From the upper controls, test the platform foot switch by selecting a boom function and moving the boom joystick without stepping on the foot switch. If movement occurs the interlock is not functioning properly. Do not operate the machine until the problem is corrected.

Movement controls

Test the operation of each control in both directions from the upper controls (refer to Figures 6.25 and 6.26).

Emergency Stop

Push the red emergency stop button **1** in to turn off the engine. The upper control functions should not operate with the emergency stop in this position.

Chapter 7. Pre-operational Inspection

☐ Emergency Power

Place the battery disconnect switch in the on position (see Figure 6.19) and pull the emergency stop button^① out to turn on the electrical power. Operate the emergency power switch^② to operate the aerial platform from the upper controls using the emergency power system.

☐ Horn

Depress the horn button^③ on the right side of the upper control panel to ensure that it sounds to warn personnel in the area.

■ RCD / ELCB Outlet

The RCD (Residual Current Device) is located at the ground and will protect against short circuits to earth. (Refer to Figure 6.27) When there is a short circuit the RCD will shut down the 230v AC power to the platform outlet.

To reset the outlet disconnect the power tool lead from the platform box and reset the RCD at the ground.

If the problem persists call a trained service technician.

The electrical outlet on the platform, and its power cable, are designed to supply 2 kW of continuous duty power to run power tools of various sorts.

The power can come from either the optional AC generator, or from an electrical source outside the SP. If you use an electrical source outside the SP be sure you disconnect it before you drive the SP away.

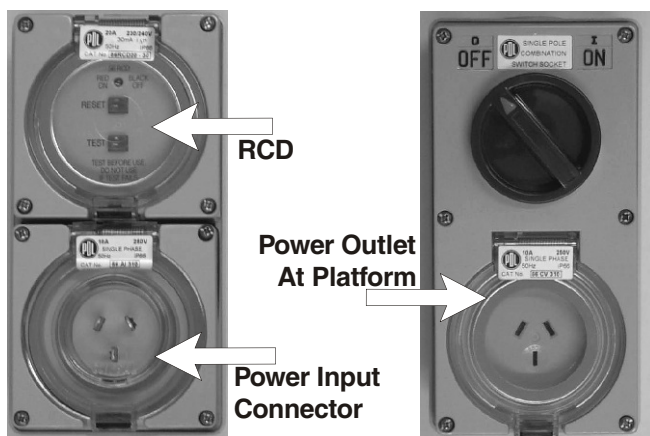

Figure 6.27—RCD / ELCB

■ Slew Lock

Before using the machine ensure that the slew lock pin is disengaged. (Refer to Figure 6.28)

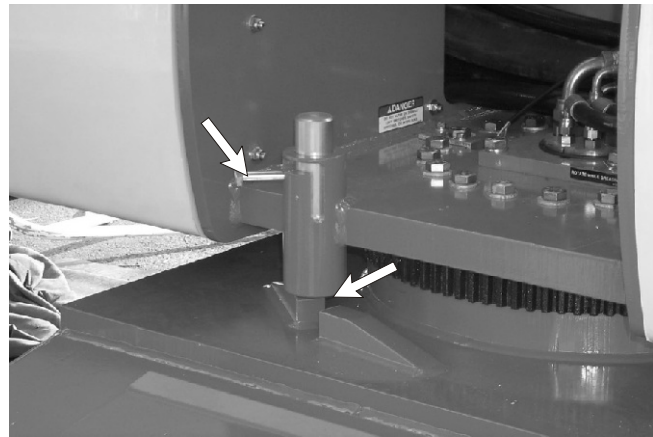

Figure 6.28—Slew Lock Pin

■ Air Line

If the machine is equipped with the optional air line, connect an air line of 250 psi (1,724 kPa) to the input connector. The input connector is at the lower rear of the turntable.

Connect an air tool to the air outlet at the platform and try to operate the tool to verify that the air line is free of kinks or holes that may prevent air flow.

■ All Motion Alarm

The machine is equipped with an all motion alarm. Drive in both the forward and reverse directions to ensure that the alarm sounds to warn personnel in the area that the aerial platform is in motion.

■ Driving and Work Lights

The machine may be equipped with driving lights and/or platform working lights. Turn the engine on and use the switch on the back of each light to momentarily turn it on to see that it works.

■ Platform Control Cover

The machine may be equipped with an optional platform control cover. Inspect the cover to ensure it fits properly over the control panel.

■ Placards and Decals

Figure 6.27 provides the item number, Snorkel part number, description, and the quantity of each placard and decal required for standard aerial platform features.

Inspect all safety and operational placards and decals. Make certain they are in place, in good condition, and are legible.

Replace any missing or illegible placards or decals before operating the aerial platform. Placard and decal kits are available from Snorkel dealers.

No	Part No	Description	Req
1	0070541	Decal - Blue arrow	3
2	0070540	Decal - Yellow arrow	3
3	12044	Decal - Lug nut torque	4
4	0323896	Decal - Danger electrocution	5
5	0073298	Decal - Foam filled tires	2
6	0112471	Decal - Snorkel	2
7	0073667	Decal - Inspect wire ropes	4
8	0190989E	Decal - Do not reach	1
9	451986	Decal - Limit switch	2
10	0323897	Decal - Must not operate	2
11	9212	Decal - Diesel	2
12	451776	Decal - Hydraulic fluid level	1
13	302950	Decal - Hydraulic oil min/max	1
14	9207	Decal - Hydraulic oil	1
15	0073492	Decal - Greasing instruction	1
16	11854	Decal - Lower control valve SP17	1
	11875	Decal - Lower control valve SP18	1
17	11857	Decal - Lower control box	1
18	9751	Decal - New Zealand made	1
19	11868	Decal - Engine tray latch	1
20	0102006	Decal - Battery disconnect	1
21	0070901E	Decal - Serial number	1
23	0072531	Decal - Electrocution hazard	1
24	11855	Decal - Upper controls SP17	1
	112001	Decal - Upper controls SP18	1
25	11856	Decal - Upper controls switch panel SP17	1
	11873	Decal - Upper controls switch panel SP18	1
26	562426	Decal - Literature compartment	1
27	0150448	Decal - Harness points	1
28	2025-227	Decal - Platform capacity	1
29	1843	Decal - Warning, New Zealand only	1
	9428	Decal - Electrical hazard, Australia only	1
30	99228	Decal - Safety harness	1
31	0073668	Decal - Do not use boom	1
32	300699	Decal - Operation check list	1
33	0323899	Decal - Electrocution hazard	1

No	Part No	Description	Req
34	11971-1	Decal - SP17	2
	11971-3	Decal - SP18	2
35	11971-2	Decal - SP17	1
	11971-4	Decal - SP18	1

Figure 6.29—Standard Feature Placards and Decals

Chapter 7. Pre-operational Inspection

□ Decal inspection drawing 1

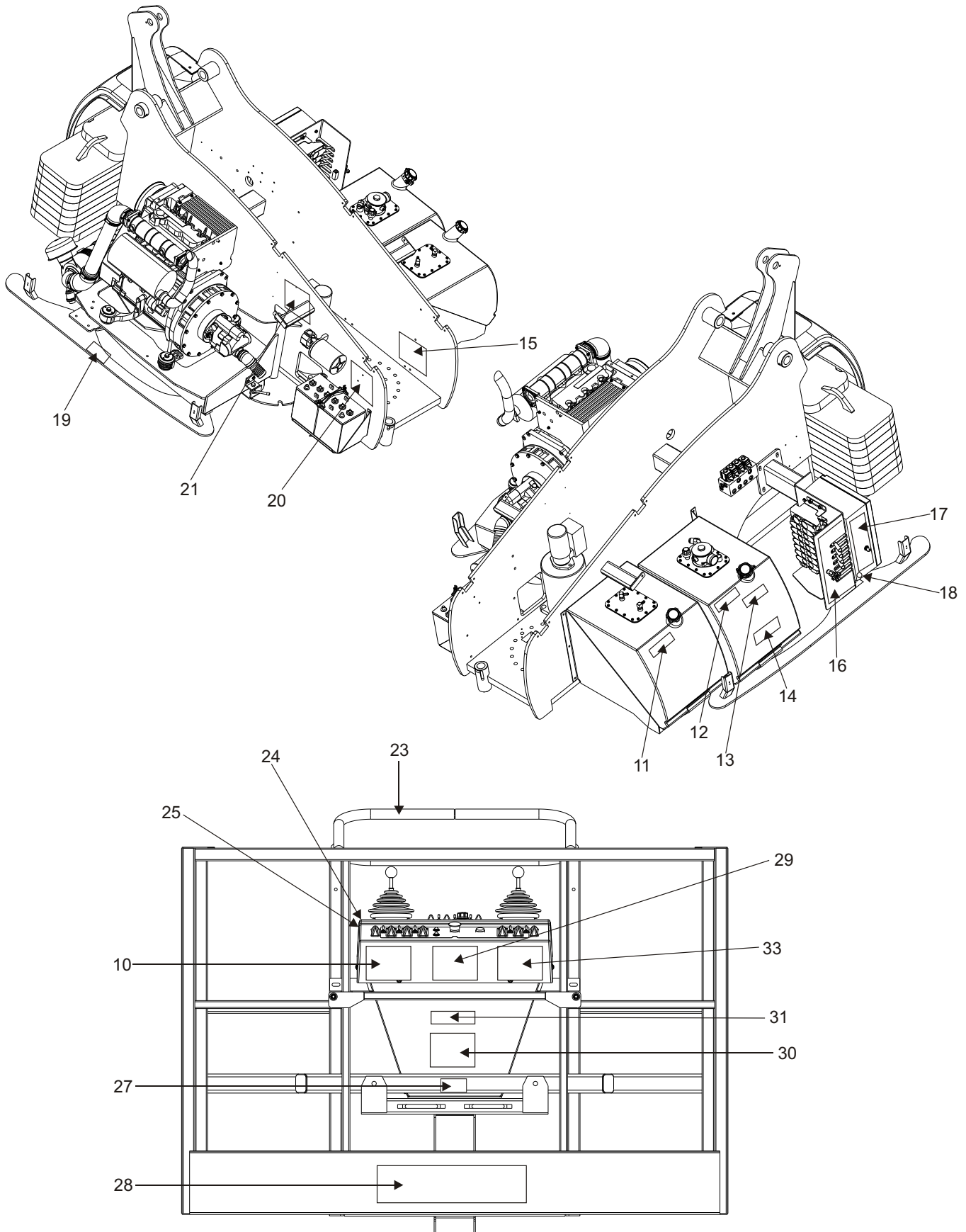

□ Decal inspection drawing 2

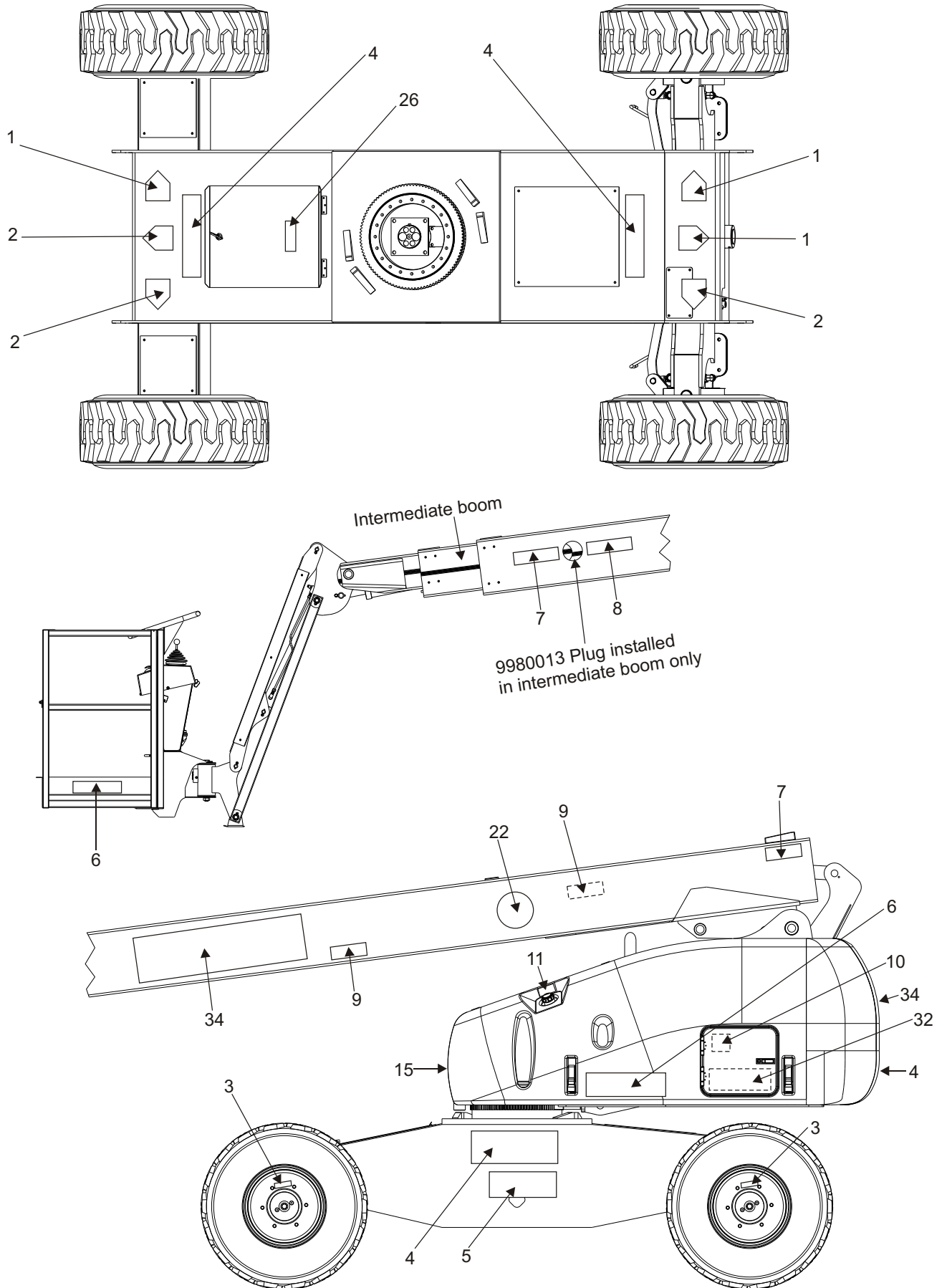

■ Operating procedures

This chapter explains how to properly start and operate an SP. Read and understand all the previous chapters in this manual and also Chapter 9 (Emergency Operation), before you begin to operate this SP.

▲ DANGER

The aerial platform is not electrically insulated. Death or serious injury can result from contact with, or inadequate clearance from, an energized conductor. Do not go closer than the minimum safe approach distance.

▲ WARNING

Pinch points may exist between moving components. Death or serious injury can result from becoming trapped between components, buildings, structures, or other obstacles. Make sure there is sufficient clearance around the machine before moving the chassis, booms, or platform. Allow sufficient room and time to stop movement to avoid contact with structures or other hazards.

▲ DANGER

The aerial platform can tip over if it becomes unstable. Death or serious injury can result from a tip-over accident. Operate the aerial platform on a firm, flat, level surface. Avoid travel speeds and/or rough terrain that could cause sudden changes in platform position.

The platform rated work load is the total weight of the personnel and equipment that may be lifted in the platform. The work loads are stated on the platform rating placard mounted on the toe-board at the front of the platform.

▲ DANGER

The aerial platform can tip over if it becomes unstable. Death or serious injury can result from a tip-over accident. Do not exceed the capacity values indicated on the platform rating placard.

Note

Capacity values indicate the rated lifting capacity and do not indicate aerial platform stability. The platform overload alarm will prevent the platform from being raised if it exceeds the lifting capacity (for those machines fitted with this safety device).

The operator bears ultimate responsibility for ensuring that the aerial platform is properly set up for the particular conditions encountered.

■ Preparing for Operation

Use the following procedure to prepare the aerial platform for operation.

1. Perform a daily inspection as described in Chapter 6.
2. Place the battery disconnect switch in the on position.
3. Close and latch the side covers.

▲ IMPORTANT

When painting or sandblasting ensure that the optional hostile environment kit is properly installed before using the machine on the job.

■ Control Stations

The aerial platform may be operated from either the ground or the platform controls.

■ Ground Controls

The ground controls override the platform controls. This means that the lower controls can always be used to operate the platform regardless of the position of the upper control emergency stop button.

Boom, turntable, and platform functions may be operated from the lower controls. The lower controls may be used for initial set up of the aerial platform and raising and lowering the platform while testing or inspection.

Use the following procedure to operate boom or platform functions using the lower controls (refer to Figure 7.1).

1. Pull the emergency stop button out **1**.

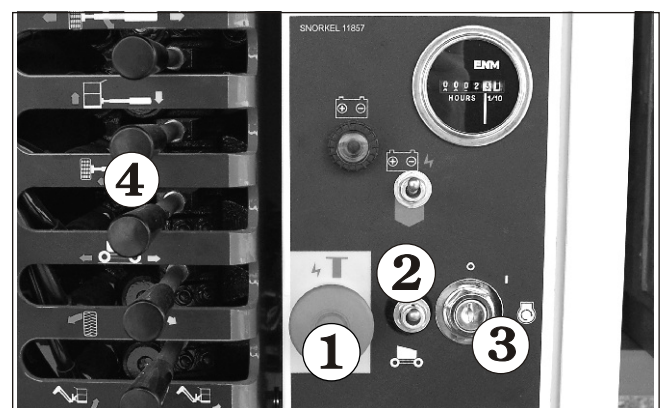

Figure 7.1—Ground Controls

Chapter 8. Operation

2. Switch to ground operation.
3. Insert the key into the master switch and turn the ignition on^②.
4. Start the engine

▲ IMPORTANT

If the engine does not start in 6 seconds release the ignition switch. Wait 60 seconds before trying to restart the engine again. Continual cranking of the starter motor may result in its damage.

5. Operate the desired boom or platform lever^④.
6. Hold the lever in the appropriate direction.
7. Release the lever to stop movement.
8. The selected function will remain active until one of the following occurs.
 - The operation lever is released.
 - The emergency stop button is pushed in.

▲ WARNING

Extreme care must be exercised if driving the SP from the ground controls.

The position of the operator will preclude seeing if other people or obstacles are at the other side of the machine.

This exercise should not be undertaken without support personnel providing visual assistance.

Additionally, great care must be taken to ensure that the machine rear wheels do not run over the operator.

■ Platform Controls

The upper controls may be used for driving the aerial platform and positioning the booms and platform while on the job.

Use the following procedure to operate boom or platform functions using the upper controls.

1. At the lower controls, insert the key into the master switch^② (refer to Figure 7.1) and turn the switch on.
2. Switch to platform operation^③ (refer to Figure 7.1).
3. Enter the platform and securely close the gate^③ (refer to Figure 7.2).
4. Attach the fall restraint harness to one of the anchor points^④ (refer to Figure 7.2).

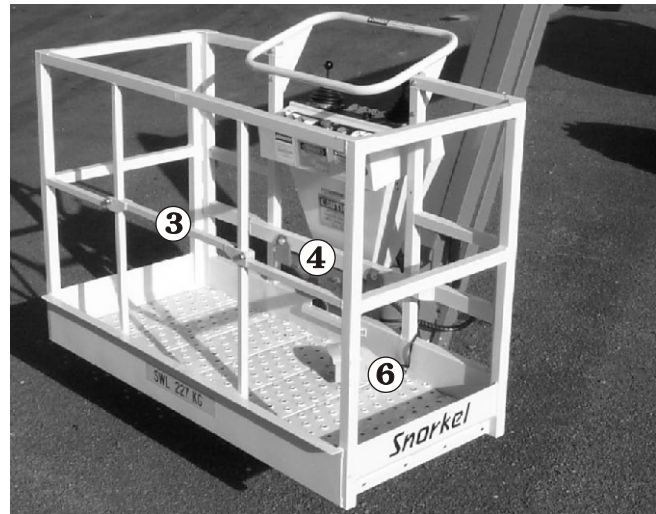

Figure 7.2—Platform

5. Pull the emergency stop button^⑤ out (refer to Figure 7.3 and 7.4).

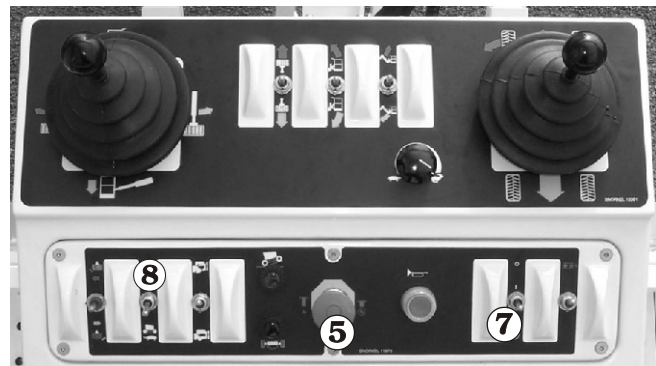

Figure 7.3—Platform Controls (Electric Controls)

6. Activate the start switch^⑦ until the engine starts, then release it.

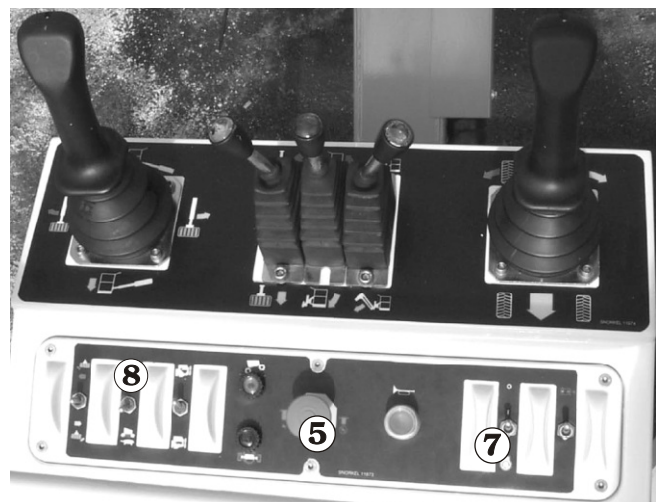

Figure 7.4—Platform Controls (Hydraulic Controls)

▲ IMPORTANT

If the engine does not start in 6 seconds release the ignition switch. Wait 60 seconds before trying to restart the engine again. Continual cranking of the starter motor may result in its damage.

7. Step down on the platform foot switch ⁶ (refer to Figure 7.2 and & 7.5).

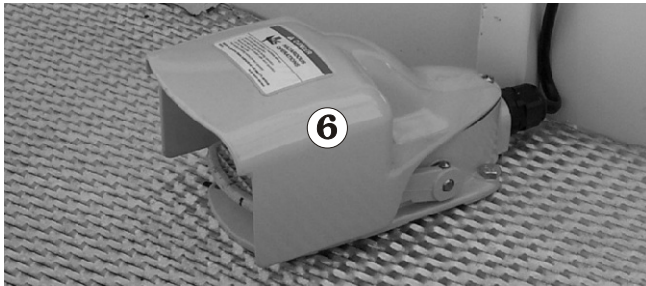

Figure 7.5—Platform Controls (Foot Switch)

□ Boom Operation

Use the following procedure to operate the turntable, boom, or platform functions.

1. Always look in the direction of movement. Move the boom joystick in the desired direction. The blue and yellow arrows by the boom joystick correspond with the direction of movement of the component selected.

For example, the yellow arrow by the main boom points downward. To move the main boom down, move the joystick toward the corresponding yellow arrow. The rate of movement is proportional to the joystick position for turntable and boom functions.

2. Return the joystick to neutral to stop movement.

□ Driving

▲ DANGER

The aerial platform can tip over if it becomes unstable. Death or serious injury can result from a tip-over accident. Do not drive an elevated aerial platform on soft, uneven, or sloping surfaces. Do not drive a fully stowed machine on grades that exceed 40 percent.

A fully stowed machine may be operated on grades up to 40 percent. A grade of 40 percent is equal to an angle of 22 degrees.

Use the following procedure to operate the drive functions.

1. Determine the desired drive range for the specific driving conditions. The system default is to the low range.
 - Use low range for driving on loading ramps or other steep grades and when safety considerations demand slow deliberate machine movement.
 - Use high range when traveling across firm, flat, level surfaces. High speed can only be activated when the booms are stowed.
2. Press the range switch ⁸ (see Figure 7.3 and 7.4) to change the drive system from low speed, high torque operation to high speed, low torque operation.
3. Move the joystick in the desired direction. The blue and yellow arrows by the joystick correspond with the direction of aerial platform movement as indicated by the arrows on the chassis.

For example, the blue arrow on the chassis points forward. To drive the machine forward, move the joystick toward the corresponding blue arrow. The drive speed is proportional to the joystick position in two separate ranges, low and high.

4. To stop drive motion, return the joystick to neutral, release the foot switch, or press the emergency stop.

□ Steering

The steer control is located on the drive and steer joystick. To turn to the left, move the joystick to the left. To turn to the right, move the joystick to the right.

Reverse the steer control direction after completing a turn to return to a straight line travel. The steering wheels are not self-centering.

■ Electrical Power Outlet

The electrical box has 2, 3-prong, 230/115 volt AC electrical connectors. Their combined output is limited by a 15 amp circuit breaker.

When electrical power is required at the platform:

- plug a source of power into the power-input connector at the rear of the chassis.
- place the Machine/Generator switch in the Generator position if the machine is equipped with an AC generator.

Unplug the source of power before moving the aerial platform.

Chapter 8. Operation

■ Air Line

The optional air line may be used to conduct air for tool operation at the platform. The input connector is at the lower rear of the turntable and the output connector is at the platform. Maximum working pressure of the line is 250 psi (1,723 kPa).

The air line may be used to conduct fluids such as water or antifreeze solution. Contact your Snorkel dealer for compatibility information before using the air line to conduct other fluids.

▲ CAUTION

Fluid in the air line can damage some air tools or freeze and damage the line. Drain and blow out the air line after using it to conduct fluids.

Use the following procedure to drain the air line.

1. Close the input connector at the turntable.
2. Open the output connector at the platform.
3. Raise the lower, main, and jib booms slightly above horizontal.
4. Open the input connector at the turntable.
5. Allow the fluid to drain from the line.
6. Lower the booms and close both connections.

If the main hydraulic system fails, the aerial platform may be lowered and stowed using the emergency power system. The main boom may be lowered using the emergency lowering knob. The machine may be towed if the drive system fails. Refer to Emergency Power System, Emergency Lowering, or Towing for the appropriate procedure.

■ Emergency Power System

The emergency power system can be used to operate the machine from the lower or upper controls.

⚠ CAUTION

The emergency power system is for emergency lowering and stowing only. The length of time the pump can be operated depends on the capacity of the battery. Do not use this system for normal operation.

Only use the emergency power system if the main power system fails.

□ Ground Controls

Use the following procedure to operate the machine using the emergency power system from the lower controls.

1. Place the battery disconnect switch in the on position (refer to Figure 8.1).

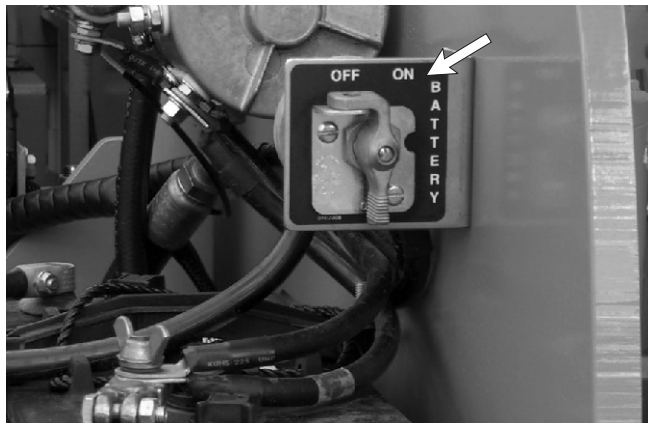

Figure 8.1—Battery Disconnect Switch

2. Place the key in the master switch^② and turn the engine on (refer to Figure 8.2).

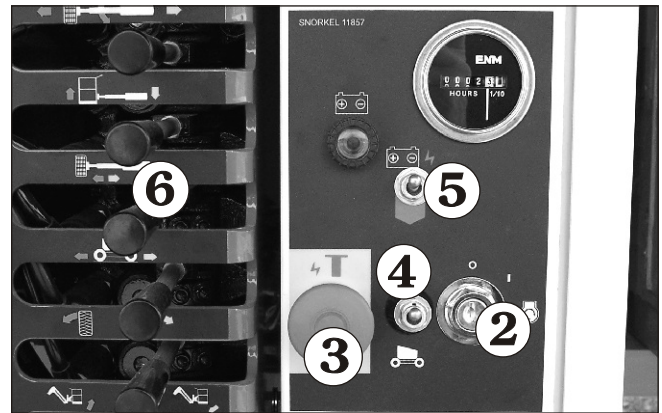

Figure 8.2—Ground Controls

3. Pull the emergency stop button^③ out.
4. Switch to ground operation^④.
5. Operate the emergency power switch^⑤.
6. Move the desired boom or platform lever^⑥.
7. Hold the lever in the appropriate direction .
8. Release the lever to stop movement.

□ Platform Controls

For the upper controls to be operational:

- the battery disconnect switch must be in the on position.
- the master switch at the lower controls must be turned on.

Use the following procedure to operate the machine using the emergency power system from the upper controls.

1. Pull the emergency stop button^① out (refer to Figure 8.3 and 8.4).

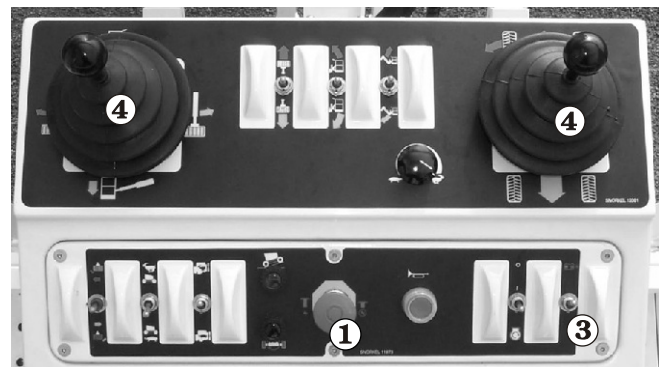

Figure 8.3—Platform Controls (Electric Controls)

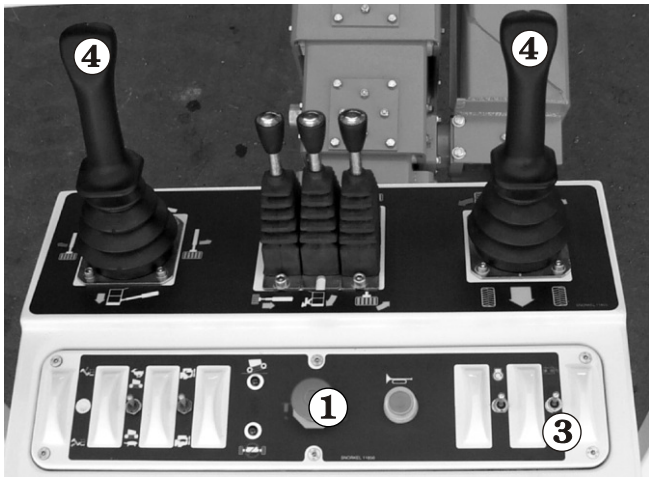

Figure 8.4—Platform Controls (Hydraulic Controls)

2. Step down on the platform foot switch (refer to Figure 8.5)

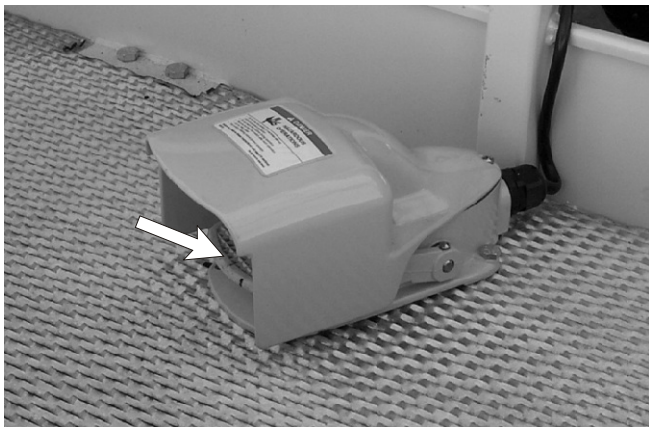

Figure 8.5—Platform Foot Switch

3. Operate the emergency power switch³ (refer to Figure 8.3 and 8.4).
4. Operate the boom or platform joystick⁴ (refer to Figure 8.3 and 8.4).
5. Move the boom joystick in the desired direction.
6. Return the joystick to neutral to stop movement.

■ Emergency Lowering

The main boom can be lowered in an emergency using the emergency lowering knob at the ground controls. The emergency lowering knob allows the main boom to be lowered only. Only use this method if the engine will not start and the emergency power system will not work.

NOTE

If the main boom is lowered below horizontal, the platform will not remain level.

Use the following procedure to manually lower the main boom.

▲ DANGER

Pinch points exist between boom components and between the booms and turntable. Death or serious injury can result if the booms or platform lowers onto personnel. Make sure all personnel stand clear while lowering the booms.

1. Slowly turn the knob¹ (refer to Figure 8.6) to open the bleed down valve. Control the rate of descent by turning the knob.

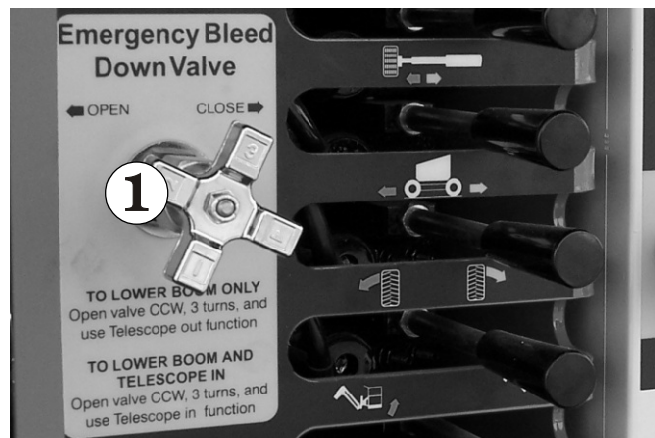

Figure 8.6—Emergency Lowering Knob

▲ DANGER

The potential for an accident increases when safety devices do not function properly. Death or serious injury can result from such accidents. Fully close the emergency lowering knob before operating the aerial platform.

2. Turn the knob¹ to close the cylinder bleed down valve.

■ Towing

The aerial platform may be towed for short periods with the speed not exceeding 2.5 km/h (1.5 mph).

The towing vehicle must be capable of safely towing and stopping the aerial platform.

The hubs (4) on each drive wheel must be placed in freewheeling mode.

⚠ DANGER

The aerial platform is free to move when the hubs are freewheeled. Death or serious injury can result. Securely fasten the tow vehicle to the aerial platform before placing the hubs in freewheel mode. The work platform can not be steered when being towed.

Use the following procedure to manually freewheel the drive hubs (refer to Figure 8.6).

1. Use a 30mm socket to unscrew (anticlockwise) the freewheel nut **1**.
2. Reverse the procedure to re-engage hubs.

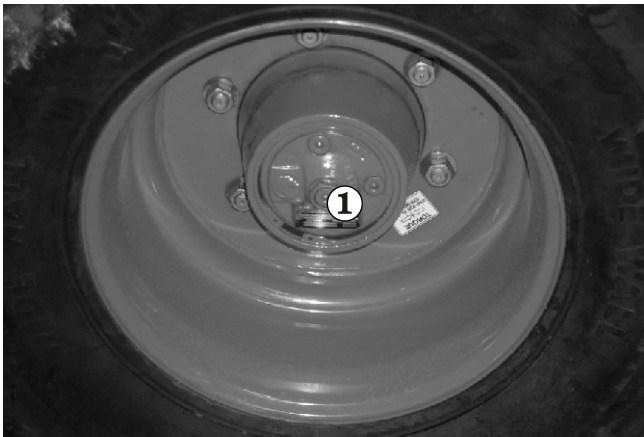

Figure 8.6—Drive Wheel Hub

To prevent unauthorized use and damage, properly stow the aerial platform at the end of each work day. It must also be properly stowed while transporting.

■ Stowing

The properly stowed position for the SP17 is shown in Figure 9.1.



Figure 9.1—Stowed Position SP17

The properly stowed position for the SP18 is shown in Figure 9.2.



Figure 9.2—Stowed SP18

Use the following procedure to properly stow the aerial platform.

1. Rotate the platform so it is perpendicular to the end of the boom.
2. Fully lower and retract the main boom.
3. Fully lower the jib boom (SP18).
4. Center the booms between the rear wheels.
5. If the engine has been under load and is hot, let it idle for five minutes.
6. Turn the master switch off and remove the key, and close the lower control panel door.
7. Turn the battery disconnect switch off.
8. On dual fuel machines, close the shut-off valve on the LPG tank.
9. Close and lock the cowling doors.

10. Engage the slew lock (see Figure 9.3)

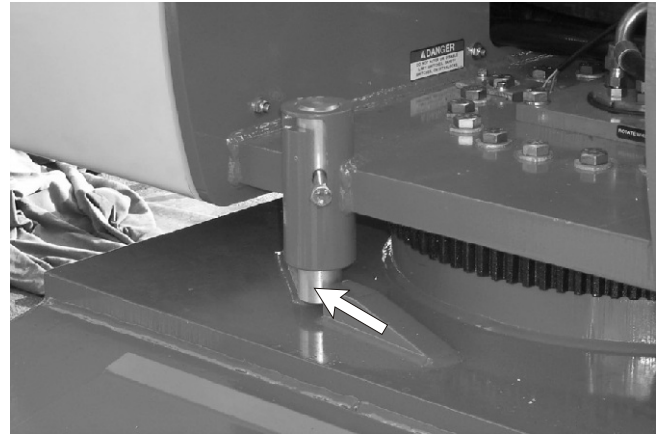

Figure 9.3—Slew Lock Pin Set

■ Transporting

The aerial platform may be moved on a transport vehicle or towed. Depending on the particular situation, the aerial platform may be driven, winched, or hoisted onto a vehicle such as a truck or trailer. Driving is the preferred method.

▲ DANGER

The aerial platform can tip over if it becomes unstable. Death or serious injury can result from a tip-over accident. Do not drive on ramps that exceed 40 percent grade, or where conditions of the ramp could cause driving to be hazardous.

Drive the aerial platform onto the transport vehicle if the ramp incline is within the 40 percent grade capability of the aerial platform.

Use a winch to load and unload the aerial platform on ramps that exceed 40 percent grade. A winch may also be used when conditions of the ramp could cause driving to be hazardous.

The equipment used to load, unload, and transport the aerial platform must have adequate capacity. Refer to Chapter 2 to determine the approximate weight of the aerial platform.

The user assumes all responsibility for making sure the equipment used is capable of supporting the weight of the aerial platform.

□ Driving

Use the following procedure to drive the aerial platform onto the transport vehicle.

1. Locate the transport vehicle so it is in a straight line with the loading ramp.

Chapter 10. Stowing and Transporting

2. Chock the vehicle wheels so it cannot roll away from the ramp while the machine is loaded.
3. Remove any unnecessary tools, materials, or other loose objects from the platform.
4. From the upper controls, drive the machine to the foot of the loading ramp with the front wheels nearest the ramp. Make sure the machine is centered with the ramps and that the steering wheels are straight.
5. Rotate the platform so it is perpendicular to the boom.
6. On a SP17, raise the main boom so it is horizontal. On a SP18, fully lower the main boom and raise the jib boom so it is horizontal.
7. Retract the main boom.
8. Rotate the turntable slightly to the side so you can see the front wheels.
9. Verify that the machine wheels, loading ramps, and transport vehicle are aligned.

▲ DANGER

The aerial platform can tip over if it becomes unstable. Death or serious injury can result from a tip-over accident. Set the drive range to low before driving up or down a grade.

10. Set the drive range to low.
11. Drive the aerial platform onto the transport vehicle in a straight line through the grade transitions with minimal turning.
12. Rotate the turntable to align the main boom between the rear wheels.
13. On a SP17, fully lower the main boom. On a SP18, fully lower the jib boom (Refer to Figure 9.4).



Figure 9.4—Stowed Position For Transporting The SP18

□ Winching

Use the following procedure to winch the aerial platform onto the transport vehicle.

1. Locate the transport vehicle so the aerial platform will not roll forward after it is loaded.
2. Remove any unnecessary tools, materials, or other loose objects from the platform.
3. From the upper controls, center the aerial platform with the loading ramps and transport vehicle bed. Make sure the steering wheels are straight.
4. Properly stow the aerial platform.
5. Attach the winch to the tie-down lugs (refer to Figure 9.5) on the front of the chassis.

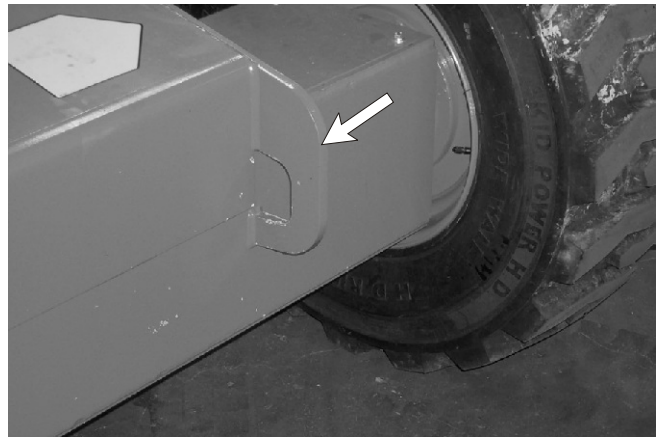

Figure 9.5—Tie-Down Lifting Lugs

6. At each drive wheel, use a 30mm socket to unscrew (anticlockwise) the free wheel nut **1** (refer to Figure 9.6).

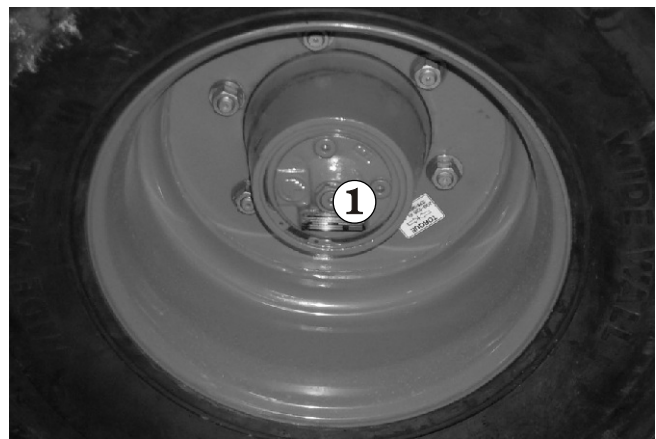

Figure 9.6—Drive Wheel

▲ DANGER

The aerial platform is free to move when the hubs are freewheeled. Death or serious

injury can result. Re-engage the hubs before operating the aerial platform.

9. Use the winch to position the aerial platform on the transport vehicle

□ Hoisting

Use a four point sling arrangement attached to the lifting lugs when hoisting the aerial platform. Machine damage can occur if the sling is attached to the booms, turntable, or platform.

▲ DANGER

The potential for an accident increases when the aerial platform is lifted using improper equipment and/or lifting techniques. Death or serious injury can result from such accidents. Use proper equipment and lifting techniques when lifting the aerial platform.

Know the weight of the aerial platform and the capacity of the lifting devices before hoisting. Lifting devices include the hoist or crane, chains, straps, cables, hooks, sheaves, shackles, slings, and other hardware used to support the machine. The gross vehicle weight is listed in Chapter 2 and is stamped on the serial number placard.

The user assumes all responsibility for making sure the equipment used is capable of supporting the weight of the aerial platform and that all manufacturer's instructions and warnings, regulations and safety rules of their employer and/or any state or federal law are followed.

Use the following procedure to hoist the aerial platform onto the transport vehicle.

1. Properly stow the aerial platform.
2. Inspect the lifting lugs (refer to Figure 9.3) to make sure they are free of cracks, rust, and are in good condition. There are two lugs on the rear of the chassis and two on the front. Have any damage repaired by a qualified service technician before attempting to hoist the machine.
3. Remove all personnel, tools, materials, or other loose objects from the platform.
4. Connect the chains or straps to the lifting eyes using bolted shackles. Hooks that fit properly in the eyes and that have latching mechanisms to prevent them from falling out under a slack line condition may also be used.

Do not run the sling cable through the lifting eyes. Cable damage and/or failure can result from the cable contacting the sharp corners of the lift eye. There is no effective way of putting a corner protector in the hole of the eye.

5. Use a spreader bars of sufficient length to keep the chains, straps, or cables from contacting the turntable or booms. When using cables, use rigid corner protectors at any point where the cable contacts on sharp corners to prevent damaging the cable. Careful rigging of the spreaders is required to prevent machine damage.
6. Use the hoist or crane to carefully raise and position the aerial platform onto the transport vehicle.

□ Securing for Transport

Use the following procedure to secure the aerial platform on the transport vehicle.

1. For a SP17, raise the main boom about 1' (0.3 m). For a SP18, raise the platform a few inches using the platform level control.
2. Place a large wood block under the rotator pylon. Lower the rotator pylon onto the wood block.
3. Remove all personnel, tools, materials, or other loose objects from the platform.
4. Turn the anti-restart and the master switch off, remove the key and close the lower control panel door.
5. Turn the battery disconnect switch off.
6. Close and lock the cowling doors.
7. Chock the wheels.
8. Use wire-ties to fasten the platform gate to the guardrails to prevent the gate from bouncing. Also, use wire-ties to fasten the platform foot switch to the platform floor.
9. Use a nylon strap to securely fasten the platform against the wood block.

▲ CAUTION

Aluminum toeboards are not strong enough to use when securing the platform to the transport vehicle. Damage to the platform will occur if the nylon strap is placed over the toeboards. Thread the strap through the platform mounting bracket when securing an aluminum platform.

Chapter 10. Stowing and Transporting

On aluminum platforms, thread the strap through the platform mounting bracket.

▲ CAUTION

Ratchets, winches, and come-alongs can produce enough force to damage machine components. Do not over tighten the straps or chains when securing the aerial platform to the transport vehicle.

11. Engage the slew lock pin (refer to Figure 9.3)
12. Use chains or straps to securely fasten the aerial platform to the transport vehicle using the tie-down lugs as attachment points. Proper tie-down and hauling are the responsibility of the carrier.

■ **Platform Control Box Cover**

This cover is provided as part of the 'harsh environment kit' but may also be purchased as a single item option.



Figure 11.1—Platform Control Box Cover

■ **Harsh Environment Kit**

This kit consists of various protective covers, filters and devices designed to reduce the effects of using the SP in environments producing quantities of abrasive contaminants.

The platform control box cover shown in Figure 11.1 is also a part of this kit.

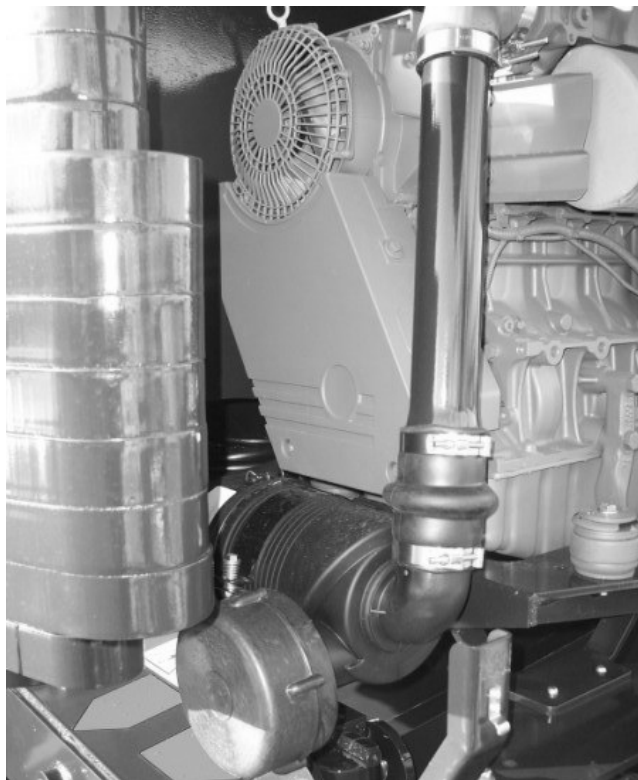

Figure 11.2—Engine Air Intake Additional Filtering

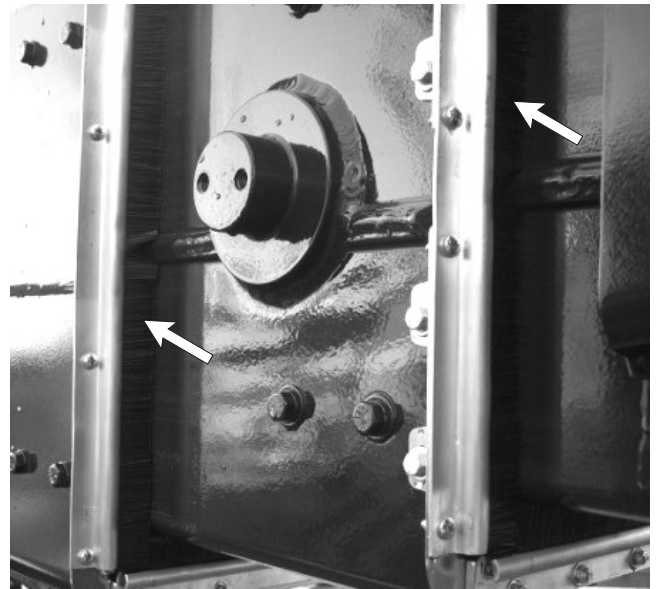

Figure 11.3—Boom Brushes

These frames with stiff bristles attached remove contaminants from the booms as they are retracted.



Figure 11.4—Cylinder Bellows Covers

■ **Optional Tow Kit**

The aerial platform may be towed using the optional tow kit. The tow vehicle must be capable of safely towing and stopping a machine with the weight of the aerial platform.

▲ DANGER

The aerial platform is free to move when the drive hubs are disabled. Death or serious injury can result. Securely fasten the tow vehicle to the aerial platform before disabling the drive hubs.

Use the following procedure to manually disengage the drive hubs and tow the machine.

Chapter 11. Options

1. With the machine in the stowed position, remove the tow bar from the storage cradle and lay it in front of the chassis (see Figure 11.5).



Figure 11.5—Towbar Storage Cradle

2. Rotate the turntable, until the counterweight is to the side of the chassis, to allow room to attach the tow kit.

▲ DANGER

Pinch points may exist between machine components. Death or serious injury can result from becoming trapped between components. Do not attach the tow kit to the tow vehicle until the counterweight is to the side of the chassis.

3. Attach the tow bar to the front axle clevis joint with the tow pin and snap pin (see Figure 11.6).



Figure 11.6—Towbar

4. Attach the tow bar to the tow vehicle.
5. Rotate the turntable so the counterweight is back at the front of the chassis. Raise the platform about 3' (1 m) above the ground.

6. Shut the engine off and turn the battery disconnect switch off.
7. Locate the steer float valve (refer to Figure 11.7) Open by turning knob anticlockwise fully.

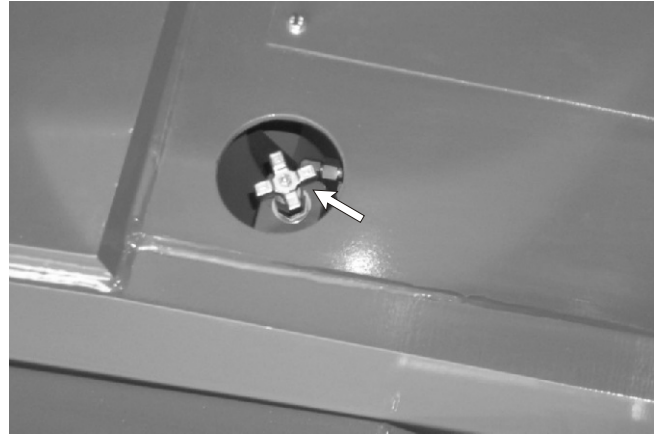

Figure 11.7—Steer Float Valve

8. At each drive wheel, remove the pin, push the center shaft in and replace the pin (refer to Figure 11.8).

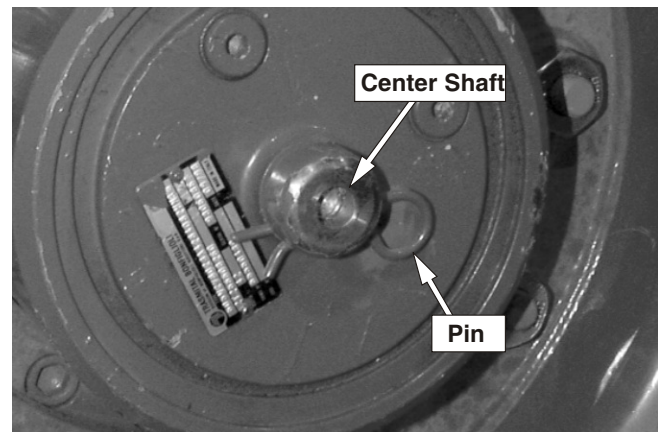

Figure 11.8—Drive Wheel

▲ CAUTION

Do not exceed 10 mile per hour (16 km/h) when towing. Use caution when turning a corner or around a curve.

▲ DANGER

The aerial platform is free to move when the drive hubs are disabled. Death or serious injury can result. Re-enable the drive hubs before operating the aerial platform.

9. At each drive wheel, remove the pin, release the center shaft to its original position and replace the pin.
10. Turn steer float valve clockwise.

11. Unfasten the tow vehicle from the machine and replace the tow kit on the storage cradles.
12. Verify that the drive system operates

■ Hazardous Components

The SP may contain the following materials and objects that potentially could become significant fire or environmental hazards during the lifetime of the SP:

1. Antifreeze (ethylene glycol)
2. Battery, lead/acid
3. Diesel fuel
4. Foam in tires
5. Gasoline
6. Hydraulic oil
7. Liquefied petroleum gas
8. Motor oil

The rest of this chapter lists manufacturers' information you will need if you ever have to control any of the above items during an upset or emergency.

□ Antifreeze (UN 1993)

☞ Fire extinguishing media:

Dry Chemical, foam, or CO₂.

☞ Special fire fighting procedures:

Water spray may be ineffective on fire but can protect fire fighters and cool closed containers. Use fog nozzles if water is used.

▲ DANGER

DO NOT enter confined fire space without full bunker gear. (Helmet with face shield, bunker coats, gloves & rubber boots). Use a NIOSH approved positive pressure self contained breathing apparatus. Keep container tightly closed. Isolate from oxidizers, heat and open flame.

☞ Spill or leak:

Small - mop up with absorbent material and transfer to hood.

☞ Waste disposal method:

Small - evaporate until all vapors are gone. Dispose of remainder by legally applicable methods.

□ Battery, Lead/Acid (UN 2794)

☞ Extinguishing media:

Dry chemical, foam, or CO₂.

☞ Special fire fighting procedures:

Use positive pressure, self contained breathing apparatus.

☞ Unusual fire and explosion hazards:

Hydrogen and oxygen gases are produced in the cells during normal battery operation.

▲ DANGER

Hydrogen gas is flammable and oxygen supports combustion. These gases enter the air through the vent caps. To avoid the chance of a fire or explosion, keep sparks and other sources of ignition away from the battery.

☞ Spill or leak:

Remove combustible materials and all sources of ignition. Contain spill by diking with soda ash (sodium carbonate) or quicklime (calcium oxide). Cover spill with either chemical. Mix well. Make certain mixture is neutral then collect residue and place in a drum or other suitable container. Dispose of as hazardous waste.

▲ DANGER

ALWAYS wear acid resistant boots, face shield, chemical splash goggles, and acid resistant gloves when handling acid spills or leaks.

Note

DO NOT release UN-neutralized acid!

☞ Waste disposal method:

Sulfuric Acid: Neutralize as above for a spill, collect residue, and place in a drum or suitable container. Dispose of as hazardous waste.

Note

DO NOT flush lead contaminated acid to sewer.

☞ Waste disposal method

Batteries: Send to lead smelter for reclamation following applicable federal, state, and local regulations.

□ Diesel Fuel (NA 1993)

☞ Extinguishing media:

Use water spray, dry chemical, foam, or CO₂.

☞ Special fire fighting procedures:

Use water to keep fire exposed containers cool. If leak or spill has not ignited, use water spray to disperse the vapors and to provide protection for

Chapter 12. Fire Fighting & Chemical Control

personnel attempting to stop a leak. Water spray may be used to flush spills away from exposures.

☞ Unusual fire and explosion hazards:

Products of combustion may contain carbon monoxide, carbon dioxide, and other toxic materials.

▲ DANGER

DO NOT enter enclosed or confined space without proper protective equipment including respiratory protection.

☞ Spill or leak:

Contain spill immediately in smallest area possible. Recover as much of the product itself as possible by such methods as vacuuming, followed by soaking up of residual fluids by use of absorbent materials.

Remove contaminated items including contaminated soil and place in proper containers for disposal. Avoid washing, draining, or directing material to storm or sanitary sewers .

☞ Waste disposal method:

Recycle as much of the recoverable product as possible.

Dispose of non-recyclable material as a RCRA hazardous waste by such methods as incineration, complying with federal, state, and local regulations.

☐ Foam In Tires

☞ Extinguishing media:

Water, dry chemical, foam, or CO₂.

☞ Special fire fighting procedures:

Evacuate non emergency personnel to a safe area.

☞ Unusual fire and explosion hazards:

Fire fighters should use self contained breathing apparatus. Avoid breathing smoke, fumes, and decomposition products.

Use water spray to drench smoldering elastomer. Product may melt, after ignition, to form flammable liquid.

▲ DANGER

Burning produces intense heat, dense smoke, and toxic gases, such as carbon monoxide, oxides of nitrogen, and traces of hydrogen cyanide.

☞ Spill or leak:

Pick up and handle as any other inert solid material.

☞ Waste disposal method:

Not considered a hazardous material. Dispose of material according to any local, state, and federal regulations.

☐ Gasoline (UN 1203)

☞ Extinguishing media:

Dry chemical, foam, or CO₂.

☞ Special fire fighting procedures:

Water may be ineffective to extinguish, but water should be used to keep fire exposed containers cool. If a leak or spill has not ignited, use water spray to disperse the vapors and to protect personnel attempting to stop a leak. Water spray may be used to flush spills away from areas of potential ignition.

☞ Unusual fire and explosion hazards:

Highly Flammable. Products of combustion may contain carbon monoxide, carbon dioxide and other toxic materials.

▲ DANGER

DO NOT enter enclosed or confined space without proper protective equipment including respiratory protection.

☞ Spill or leak:

Review fire and explosion hazards before proceeding with clean up. Use appropriate personal protective equipment during clean up. Dike spill. Prevent liquid from entering sewers, waterways, or low areas. Soak up with sawdust, sand, oil dry or other absorbent material. Shovel or sweep up.

Remove source of heat, sparks, flame, impact, friction or electricity including internal combustion engines and power tools. If equipment is used for spill cleanup, it must be explosion proof and suitable for flammable liquid and vapor.

Note:

Vapors released from the spill may create an explosive atmosphere.

☞ Waste disposal method:

Treatment, storage, transportation and disposal must be in accordance with applicable federal, state, provincial, and local regulations.

▲ CAUTION

DO NOT flush to surface water or sanitary sewer system. By itself, the liquid is expected to be a RCRA ignitable hazardous waste.

Hydraulic Oil (UN 1270)

Extinguishing media:

Use water spray, dry chemical, foam, or CO₂.

Special fire fighting procedures:

Water or foam may cause frothing. Use water to keep fire exposed containers cool. Water spray may be used to flush spills away from exposures.

Unusual fire and explosion hazards:

Products of combustion may contain carbon monoxide, carbon dioxide, and other toxic materials.

▲ DANGER

DO NOT enter enclosed or confined space without proper protective equipment including respiratory protection.

Spill or leak:

Contain spill immediately in smallest area possible. Recover as much of the product itself as possible by such methods as vacuuming, followed by soaking up of residual fluids by use of absorbent materials.

Remove contaminated items including contaminated soil and place in proper containers for disposal. Avoid washing, draining or directing material to storm or sanitary sewers .

Waste disposal method:

Recycle as much of the recoverable product as possible.

Dispose of non-recyclable material as a RCRA hazardous waste by such methods as incineration, complying with federal, state, and local regulations.

Liquefied Petroleum Gas (UN 1075)

Extinguishing media:

Water spray. Class A-B-C or BC fire extinguishers.

Special fire fighting procedures:

Stop flow of gas. Use water to keep fire exposed containers cool. Use water spray to disperse unignited gas or vapor.

If ignition has occurred and no water available, tank metal may weaken from over heating. Evacuate area. If gas has not ignited, LP gas liquid or vapor may be dispersed by water spray or flooding.

Unusual fire and explosion hazards:

Highly Flammable. Products of combustion may contain carbon monoxide, carbon dioxide and other toxic materials.

▲ DANGER

DO NOT enter enclosed or confined space without proper protective equipment including respiratory protection.

Spill or leak:

Keep public away. Shut off supply of gas. Eliminate sources of ignition. Ventilate the area. Disperse with water spray.

Contact between skin and these gases in liquid form can cause freezing of tissue causing injury similar to thermal burn.

Note:

Vapors released from the spill may create an explosive atmosphere.

Waste disposal method:

Treatment, storage, transportation and disposal must be in accordance with applicable federal, state, provincial, and local regulations.

Motor Oil (UN 1270)

Extinguishing media:

Use water spray, dry chemical, foam, or CO₂.

Special fire fighting procedures:

Water or foam may cause frothing. Use water to keep fire exposed containers cool. Water spray may be used to flush spills away from exposures.

Unusual fire and explosion hazards:

Products of combustion may contain carbon monoxide, carbon dioxide, and other toxic materials.

▲ DANGER

DO NOT enter enclosed or confined space without proper protective equipment including respiratory protection.

Spill or leak:

Chapter 12. Fire Fighting & Chemical Control

Contain spill immediately in smallest area possible. Recover as much of the product itself as possible by such methods as vacuuming, followed by soaking up of residual fluids by use of absorbent materials.

Remove contaminated items including contaminated soil and place in proper containers for disposal. Avoid washing, draining or directing material to storm or sanitary sewers .

Waste disposal method:

Recycle as much of the recoverable product as possible.

Dispose of non-recyclable material as a RCRA hazardous waste by such methods as incineration, complying with federal, state, and local regulations.

The chart below lists situations where machine operation may be interrupted. If the problem cannot be corrected with the action listed, stow the machine and remove it from service. Repairs must be made by qualified maintenance personnel.

■ Troubleshooting Chart

Symptom	Possible Cause	Corrective Action
All Functions stop working.	Low fluid level in reservoir. Circuit breaker on the lower control panel has tripped. Motor or pump failure. Electrical system malfunction.	Check fluid level. Add correct type of fluid if necessary. Wait one minute for circuit breaker to reset. Manually stow the machine using emergency power system. Manually stow the machine using emergency power system.
Lower controls do not work.	Ground operation not selected. Battery disconnect switch turned off. Emergency stop button at lower controls is pushed inward to the off position.	Hold ground operation button in while operating control buttons. Place switch in the on position. Pull emergency stop button outward to the on position.
Upper controls do not work.	Battery disconnect switch turned off. Emergency stop button at upper controls is pushed inward to the off position. Platform foot switch not engaged.	Place switch in the on position. Pull the emergency stop button outward to the on position. Step down on platform foot switch while operating joysticks.
Booms drift down.	Hydraulic system malfunction.	Stow the machine and do not operate until repairs are made.
Drive functions do not work.	Load capacity exceeded. Machine on too steep a grade. Brakes disengaged. Low hydraulic system pressure.	Remove load from platform. Refer to platform capacity placard for maximum capacity. Lower the booms and drive to a level surface. Engage brakes. Stow the machine and do not operate until repairs are made.
Only slow drive speed works.	High range not selected. Lower boom is raised out of its rest.	Press range button to engage high speed. Completely lower the lower boom.
Wheels will not turn when winching.	Brakes engaged.	Dis-engage brakes.
Brakes do not work.	Brakes disengaged.	Engage brakes.
Electrical outlet does not work.	Power supply not plugged in. GFCI is tripped.	Plug a source of power into the power-input connector at rear of chassis. Push reset button on outlet.

Chapter 13. Troubleshooting

Symptom	Possible Cause	Corrective Action
Circuit breaker will not reset.	Circuit breaker has not had time to reset. Electrical system malfunction.	Wait one minute for circuit breaker to reset. Do not operate machine until repairs are made.
Hydraulic fluid temperature 200°F (93°C) or more.	Prolonged driving or boom operation. High pressure fluid return to reservoir caused by kinked or twisted hose. Hydraulic system component failure.	Stop operation until fluid cools. Remove the kink or twist from the hose. Let fluid cool before resuming operation. Stow the machine and do not operate until repairs are made.
Severe hydraulic leak.	Failure of hose, tube, fitting, seal, etc.	Do not operate machine until repairs are made.

aerial platform—a mobile device that has an adjustable position platform, supported from ground level by a structure.

authorized personnel—personnel approved as assigned to perform specific duties at a specific location.

base—the relevant contact points of the aerial platform that form the stability support (e.g. wheels, casters, outriggers, stabilizers).

boom—a movable cantilever beam which supports the platform.

center of gravity—the point in the aerial platform around which its weight is evenly balanced.

chassis—the integral part of the aerial platform that provides mobility and support for the booms.

fall restraint—a system that is used while working on a boom lift within the boundaries of platform guardrails to provide restraint from being projected upward from the platform. This system includes a harness or belt, lanyard, and a lanyard anchor. Federal OSHA, ANSI, and Snorkel require the use of additional fall protection beyond the platform guardrails on boom supported aerial platforms.

gradeability—the maximum slope that the aerial platform is capable of travel.

ground fault circuit interrupter—a fast-acting circuit breaker that opens to stop electrical circuit flow if it senses a very small current leakage to ground. Also called GFCI. The GFCI is used to protect personnel against a potential shock hazard from defective electrical tools or wiring.

guardrail system—a vertical barrier around the platform to prevent personnel from falling.

hazardous location—any location that contains, or has the potential to contain, an explosive or flammable atmosphere as defined by ANSI/NFPA 505.

jib boom—a boom assembly located between the main boom and the platform.

lower controls—the controls located at ground level for operating some or all of the functions of the aerial platform.

main boom—a boom assembly located between the turntable and the platform or jib boom. The main boom includes the base, intermediate, and tip boom.

maximum travel height—the maximum platform height or the most adverse configuration(s) with respect to stability in which travel is permitted by the manufacturer.

Minimum Safe Approach Distance—the minimum safe distance that electrical conductors may be approached when using the aerial platform. Also called MST

personal fall arrest system—a fall protection system that is used while working on an unprotected edge (such as a roof top with no guardrail). This system includes a harness, lanyard or other connecting device, a fall arrestor, an energy absorber or decelerator, an anchorage connector, and a secure anchorage such as a building beam, girders or columns. An aerial platform is not a fall arrest anchorage.

platform—the portion of an aerial platform intended to be occupied by personnel with their tools and materials.

platform height—the vertical distance measured from the floor of the platform to the surface upon which the chassis is being supported.

qualified person—a person, who by reason of knowledge, experience, or training is familiar with the operation to be performed and the hazards involved.

rated work load—the designed carrying capacity of the aerial platform as specified by the manufacturer.

stow—to place a component, such as the platform, in its rest position.

turntable—the structure above the rotation bearing which supports the main boom. The turntable rotates about the centerline of rotation.

unrestricted rated work load—the maximum designed carrying capacity of the aerial platform allowed by the manufacturer in all operating configurations.

upper controls—the controls located on or beside the platform used for operating some or all of the functions of the aerial platform.

working envelope—the area defined by the horizontal and vertical limits of boom travel that the platform may be positioned in.

E

Electrical Hazard Warning
see Electrical Hazard - page i

H

Hazardous Components, 12-9
Antifreeze (UN 1993), 12-9
Battery, Lead/Acid (UN 2794), 12-9
Diesel Fuel (NA 1993), 12-9
Foam In Tires, 12-10
Gasoline (UN 1203), 12-10
Hydraulic Oil (UN 1270), 12-11
Liquefied Petroleum Gas (UN 1075), 12-11
Motor Oil (UN 1270) , 12-11

M

manual of responsibilities, -iv
Minimum Safe Approach Distance
see Electrical Hazard - page ii

S

safety alerts, -iii

W

Warranty - Limited
see inside front cover