

TELESCOPING JIB BOOM

SNORKEL SP18

Snorkel

ELEVATING WORK PLATFORMS



THE SNORKEL ADVANTAGE

**BUILT TOUGH
EXCELLENT SERVICEABILITY
LOW OWNERSHIP COSTS**

www.snorkel.com.au

SNORKEL SP18

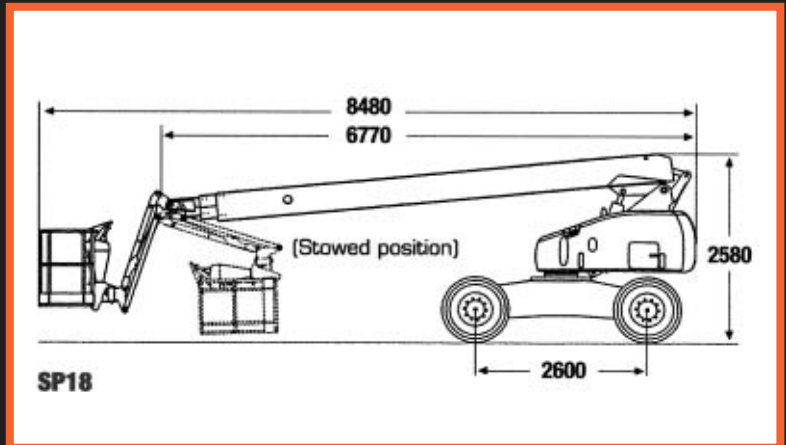
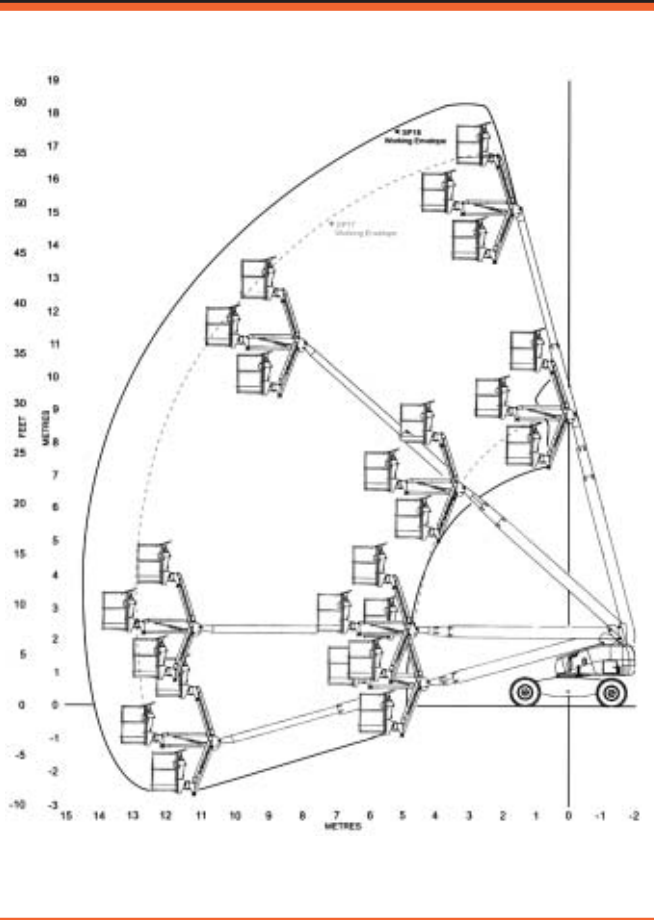

SPECIFICATIONS

PLATFORM

Working Height	60'	18.3m
Platform Height	54'	16.5m
Size	30" x 67.5"	780 x 1717mm
Capacity	500lbs	227kgs
Construction	Steel	

MACHINE DIMENSIONS

Stowed Length	22'	6.7m
Stowed Height	8' 4"	2.58m
Wheelbase	8' 5"	2.6m
Width	7' 4"	2.27m
Ground Clearance	1' 4"	440mm
Weight	13,999lbs	6350kgs
Tire Size	14 x 17.5 x 14 ply (foam filled)	

PERFORMANCE

Power Source	Diesel Engine	
Fuel Capacity	100 litres	
Hydraulic Capacity	100 litres	

DRIVE SPEED

Elevated	1mph	1.6km/h
Stowed Max	2.5mph	4km/h
Gradeability	40%	
Horizontal Reach	46'	14m

STANDARD FEATURES

- 4 degree level sensor
- Foam filled tyres
- Three section telescoping boom, steel base boom & aluminium intermediate and tip booms
- Automatic terrain following steer axle
- -72°/+72° articulating boom
- Proportional drive, lift, and slew
- Drive motion alarm
- Manual bleed down at chassis
- 180° hydraulic platform rotation

- Hour meter, high engine temperature and low oil pressure shut down
- 4 wheel drive
- Base controls include drive & steer function
- Flashing light
- 360° continuous turntable rotation

ADDITIONAL OPTIONS

- AC generator
- Bump guard
- Non marking tyres
- 240V outlet
- Air hose to platform
- Wide platform

Danger: Models described in this brochure are NON-INSULATED and do not provide electrocution protection from contact with or close proximity to energised conductors which is pointed out on decals and placards attached to the machine. Only qualified and trained operators are to be authorised to use and operate a work platform. Aerial work platforms must be elevated only on firm, level surface.

Products in this brochure comply with relevant ANSI and Australian Standards. This literature is for illustrative purposes only. Consult Operating/Maintenance and Parts Manuals for proper procedures. Specifications may vary and are subject to change without notice.

Snorkel
ELEVATING WORK PLATFORMS
DEALER STICKER

AUSTRALIA

2/26 Redfern Street
Wetherill Park, NSW 2164

Phone +61 2 9725 4000
Fax +61 2 9609 3057

NEW ZEALAND

36 Bruce Road
Levin, New Zealand

Phone +64 6 3689 168
Fax +64 6 3689 164

USA

2009 Roseport Road
Elwood, KS 66024

Phone 785 989 3000
Fax 785 989 3070