

Genie® GS™ -3384

Specifications

Models	GS-3384	
Measurements	US	Metric
Working height max. ⁽¹⁾	39 ft	12.06 m
A Platform height max.	33 ft	10.06 m
B Platform height - stowed ⁽²⁾	5 ft 1 in	1.55 m
C Platform length - outside	12 ft 11.25 in	3.94 m
Platform length - Outside, extended single deck	17 ft 6.25 in	5.34 m
D Platform length - Outside, extended dual deck	21 ft 6.5 in	6.57 m
E Slide-out platform extension deck - front	5 ft	1.52 m
F Slide-out platform extension deck - rear	4 ft	1.22 m
G Platform width - outside	6 ft	1.83 m
H Height - stowed (folding rails)	8 ft 9.5 in	2.68 m
Height - stowed (rails lowered)	6 ft 6.75 in	2.0 m
I Length - stowed, single deck	12 ft 11.25 in	3.94 m
Length - stowed, dual deck	13 ft 0.5 in	3.98 m
Length - stowed, with outriggers	16 ft	4.88 m
Length - extended, single deck	17 ft 9 in	5.40 m
Length - extended, dual deck	21 ft 6.5 in	6.57 m
J Width (standard tires)	7 ft	2.13 m
K Wheelbase	9 ft 4 in	2.84 m
L Ground clearance (center)	13 in	33 cm

Productivity

Max. platform occupancy (in/out)	7/7	
Lift capacity	2,500 lb	1,134 kg
Lift capacity - extension deck extended	500 lbs	227 kg
Max. platform drive height	33 ft	10.06 m
Drive speed - stowed	5.0 mph	8.0 km/h
Drive speed - raised	0.7 mph	1.1 km/h
Gradeability - stowed ⁽³⁾	50%	
Turning radius - inside/outside	10 ft 1.5 in / 19 ft 6 in	3.09 m / 5.94 m
Lifting speed - raise/lower	45/29 sec	
Tilt sensor activation (front to back / side to side)	3° / 2°	
Max. outrigger leveling (front to back / side to side)	7° / 12°	

Drive

Tires - Foam-filled rough terrain	10×31 in	25×79 cm
-----------------------------------	----------	----------

Power

Power	Diesel	
Fuel Tank	20 gal	75.7 L
Hydraulic tank capacity	30 gal	113.6 L

Weight⁽⁴⁾ and Floor Loading⁽⁵⁾

Weight	11,825 lb	5,364 kg
Weight with outriggers	13,500 lb	6,124 kg
Additional weight, optional dual deck	784 lb	356 kg
Additional weight, optional super deck	906 lb	411 kg
Additional weight, optional generator	50 lb	23 kg
Tire load max.	4,689 lb	2,127 kg
Tire contact pressure - front, platform fully extended	128.5 psi	886 kPa
Occupied floor pressure	177 psf	8.49 kPa

Sound and Vibration Levels

Sound Pressure level (ground workstation)	< 88 dBA	
Sound Pressure level (platform workstation)	< 78 dBA	
Vibrations	< 8 ft 2 in/s ²	< 2.5 m/s ²

(1) The metric equivalent of working height adds 2 m to platform height. US adds 6 ft to platform height.

(2) Based on RT tires; deduct 2 in/5.8 cm for turf and non-marking tires.

(3) Gradeability applies to driving on slopes and may vary depending on options and machine configurations. See operator's manual for details regarding slope ratings.

(4) Weight refers to standard configuration and may vary depending on options and/or country standards.

(5) Floor loading information is approximate and may vary depending on options and machine configurations. It should be used only with adequate safety factors.

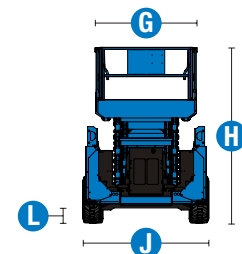
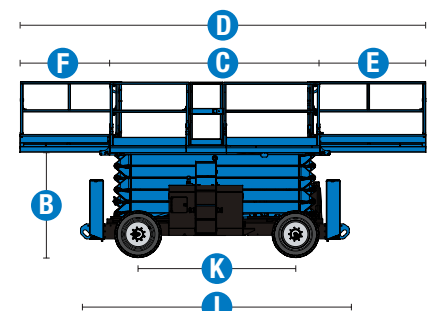
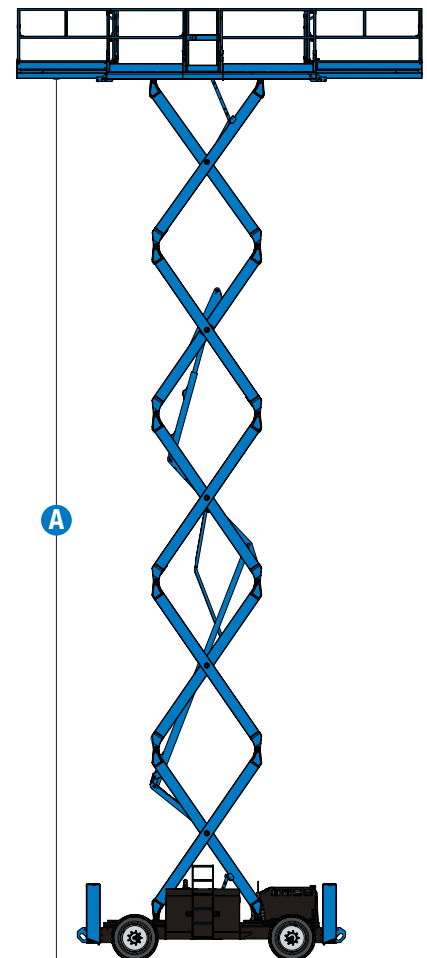

Genie® GS™ -3384

SKU: Standard Model

- GS-3384*

* Build to Order

Option availability		S	S+	BtO
Power	48.7 hp, 36.3 kW, Deutz D2.9L, Diesel, T4f			✓
	60 hp, 44.7 kW, Ford 2.5L, Gas/LPG			○
	Cold weather package			○
Platform	Single slide-out extension deck			✓
	Dual slide-out extension deck			○
	Folding rails, Full-height swing gate			✓
	Self-closing entry gate			✓
	Air line to platform			○
	2kW AC Generator, 110V/60Hz			○
	AC power to platform			✓
	Diamond plate platform deck			✓
	Electronic horn			✓
	Lanyard attachment points			✓
	Platform control guard (PCON)			✓
	Platform load sense system			✓
	Proportional drive and lift			✓
Chassis	Auto leveling hydraulic outriggers			○
	Lift Connect Telematics			○
	Lift Connect with Access Manager upgrade			○
	Biodegradable hydraulic oil			○
	Cold weather hydraulic oil			○
	Rough Terrain, foam-filled tires (water based)			✓
	Rough Terrain, foam-filled tires (petroleum based)			○
	Rough Terrain, foam-filled, non-marking tires (petroleum based)			○
	Rough Terrain, foam-filled, non-marking tires (water based)			○
	High floatation, foam-filled tires			○
	Dual LED flashing beacons			✓
	Hydraulic oil cooler			○
	LPG tank 33.5 lb			○
	4 wheel drive			✓
	Descent, tilt and motion alarm			✓
Sealed AC drive motors			✓	

- S Standard
- S+ Standard +
- BtO Build to Order
- ✓ Standard Features
- Options



4 Wheel Drive



50% Gradeability



Slide-Out Engine Tray



Genie Genuine Accessories⁽¹⁾

- Lift Tools Productivity Tools
- Lift Connect Telematics
- Tech Pro Link Handheld Device

(1) More accessories available from Genie Genuine Parts.

Product specifications are subject to change without notice or obligation. Photographs and/or drawings herein are for illustrative purposes only. Refer to the appropriate Operator's Manual for instructions on proper equipment use. Failure to follow instructions in the Operator's Manual may result in serious injury or death. The only warranty applicable to our equipment is the standard written warranty applicable to the particular product and sale and we make no other warranty, express or implied. Products and services listed may be trademarks, service marks or trade names of Terex Corporation and/or their subsidiaries in the USA and many other countries. Terex, Genie, Quality By Design, Xtra Capacity, Lift Power, Lift Guard, Lift Tools, Lift Connect and Tech Pro Link are registered trademarks of Terex Corporation or its subsidiaries.

Updated 08/21



A TEREX BRAND
© 2021 Terex Corporation

