

*Reference use and maintenance manual*

EN

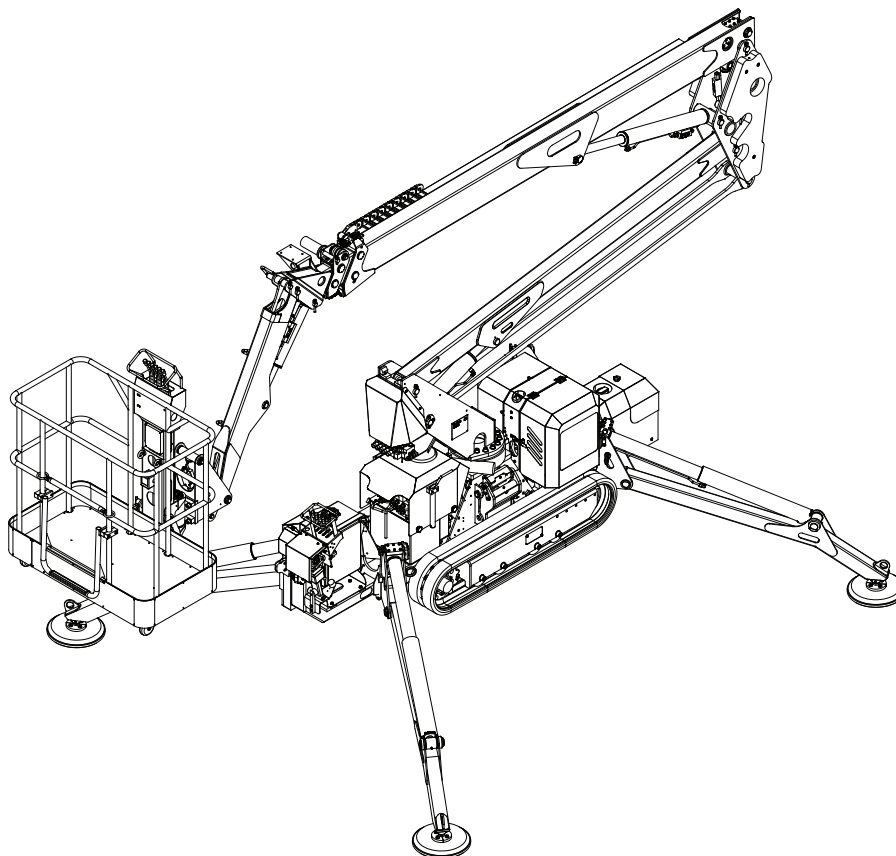

# SPIDER 18.90 PRO

## *Aerial work platform*



**Attention**

Before proceeding with any work on the machine read the present handbook in its entirety and ensure you understand the information contained herein.

Keep the handbook in a safe place where it is easily accessible for consultation.

**ORIGINAL INSTRUCTIONS**

Code

4848520200

Version

05/2012

**BUILDER: PLATFORM BASKET**

**ADDRESS: Via Grande, 27**  
**42028 Poviglio (RE) – Italy**  
**Tel: +39 0522967666**  
**Fax: +39 0522967667**  
**www.platformbasket.com**

**DOCUMENT TYPE: OWNER'S MANUAL**

**MODEL: SPIDER 18.90 PRO**

**SERIAL NUMBER:**

**CUSTOMER:**

**YEAR OF MANUFACTURE:**

The contents of the present document cannot be used, reproduced or transferred to third parties without the express permission of builder.

The builder reserves the right to change the characteristics of the machine described in the present document without notice.



002

---

## INTRODUCTION

Dear Clients,  
Platform Basket thanks you for your choice

Your new access equipment is the result of an innovative approach and the pursuit of quality. It has been designed to be functional, safe, comfortable and durable with style and excellent operating features.

When your machine requires maintenance, only the spare parts supplied by us must be used in order to ensure reliability and suitability.



003

---

## PURPOSE OF THE MANUAL

The purpose of this manual is to provide the users with the essential knowledge for carrying out the procedures necessary for the proper working of the machine and for the purposes for which it is intended. All the information contained in this manual must be READ and ASSIMILATED before undertaking any attempt to operate the machine.

THE OWNER'S MANUAL is the most important instrument. Keep it in the machine. Remember that NO EQUIPMENT IS SAFE if the operator does not observe the safety precautions.

Since the manufacturer has no direct control over the operation and applications of the machine, the appropriate safety procedures are entrusted to the responsibility of the user and the user's personnel.

All the instructions contained in this manual are based on the use of the machine when it is working CORRECTLY, without alterations and/or modifications to the original model. Any alteration and/or modification to the machine is SEVERELY PROHIBITED, without the prior authorization of Platform Basket.



This "SAFETY SYMBOL" is used to call attention to potential dangers which may cause injury or death if they are underestimated.

The safety of personnel and the appropriate operation of the machine must be the main concern. DANGER, BEWARE, CAUTION, IMPORTANT, etc. signs are included in everywhere in this manual in order to highlight the danger areas. They are defined as follows:



### **DANGER**

*Indicates a situation of imminent danger which will cause serious injury or death if not avoided.*



### **BEWARE**

*Indicates a potentially dangerous situation which may cause minor or moderate injuries if not avoided.*

*This sign may also be used as a warning against dangerous practices.*



### **WARNING**

*WARNING or INSTRUCTIONS indicates a procedure indispensable for safe operating conditions and if not followed may cause a malfunction or damage to the machine.*

---



## INDEX

### **002**

INTRODUCTION

### **003**

PURPOSE OF THE MANUAL

### **004**

INDEX

### **005**

CONSULTATION

## SECTION **A**

INSTRUCTIONS AND GENERAL SAFETY RULES

### **A01**

INTRODUCTION

### **A02**

MACHINE IDENTIFICATION

### **A03**

GENERAL SAFETY RULES

### **A04**

PREPARATION AND INSPECTION

### **A05**

SIGNS AFFIXED TO THE MACHINE

### **A06**

QUALIFICATION OF OPERATING PERSONNEL

### **A07**

CUSTOMER'S RESPONSIBILITY AND MACHINE CONTROLS

### **A08**

OPERATING POSITIONS

### **A09**

THE ROLE OF THE OPERATORS



---

**INDEX**

**SECTION B**  
DESCRIPTION AND USE OF THE MACHINE

**B01**  
TECHNICAL INFORMATION

**B02**  
GENERAL DESCRIPTION

**B03**  
SAFETY DEVICES

**B04**  
GROUND CONTROL PANEL

**B05**  
ELECTRIC PUMP CONTROL PANEL

**B06**  
CONTROLS FOR MOVEMENT/ STABILISATION

**B07**  
GROUND CONTROL LEVERS (FOR THE AERIAL PARTS)

**B08**  
CONTROL PANEL ON THE BASKET

**B09**  
CONTROL LEVERS IN THE BASKET

**B10**  
OTHER DEVICES

**B11**  
TRANSPORT

**B12**  
SWITCH ON / SWITCH OFF

**B13**  
USE OF THE MACHINE

**B14**  
EMERGENCY MANOEUVRES



## INDEX

### SECTION **C** MAINTENANCE

**C01**  
INTRODUCTION

**C02**  
MAINTENANCE WORK SAFETY

**C03**  
MAINTENANCE SCHEDULE

**C04**  
GREASING AND LUBRICATION

**C05**  
LUBRICANT TABLE

**C06**  
SCREW TIGHTENING

**C07**  
SUPPLIES

**C08**  
CHECK OIL LEVEL / TOP UP / REPLACE TRACK REDUCTION GEAR OIL

**C09**  
HYDRAULIC OIL LEVEL CHECK

**C10**  
SLIDING BLOCK WEAR AND CHAINS CONTROL (WHERE THERE ARE)



**INDEX**

**SECTION D**  
REGISTER AND CONTROL COUPONS

**D01**  
MAINTENANCE RECORDS AND LOGBOOK

**D02**  
CHANGE OF OWNERSHIP RECORD

**D03**  
MAINTENANCE RECORD SPARE PART REPLACEMENT RECORD

**D04**  
MAINTENANCE RECORDS

**SECTION EA**  
INTEGRATION FOR RADIO COMMAND VERSION

**E01**  
SIGNS AFFIXED TO THE MACHINE

**E02**  
GENERAL DESCRIPTION

**E03**  
TRAVELLING / STABILISATION COMMANDS

**E04**  
EMERGENCY MANOEUVRE

**SECTION EB**  
INTEGRATION FOR CABLE COMMAND VERSION

**E01**  
SIGNS AFFIXED TO THE MACHINE

**E02**  
GENERAL DESCRIPTION

**E03**  
TRAVELLING / STABILISATION COMMANDS

**E04**  
EMERGENCY MANOEUVRE



---

**INDEX**

**SECTION F**  
OPTION

**F01**  
TEMPERATURE SENSOR

**F02**  
BASKET WITH LOAD CELL

**F03**  
HORN





## CONSULTATION



**BEWARE**

*It is necessary to read and understand the manual before using the machine.*

The manual is subdivided into 8 sections

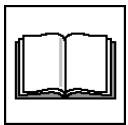

***INTRODUCTION OF THE HANDBOOK***



**A**

***SAFETY INSTRUCTIONS AND RULES***

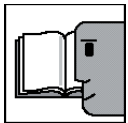

**B**

***USER MANUAL***



**C**

***MAINTENANCE***



**D**

***LOGBOOK AND CONTROL COUPONS***

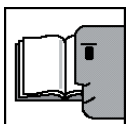

**EA**

***INTEGRATION FOR RADIO COMMAND VERSION***

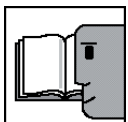

**EB**

***INTEGRATION FOR CABLE COMMAND VERSION***

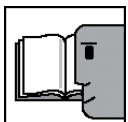

**F**

***OPTIONAL***

---

**SECTION**

**A**



***INSTRUCTIONS AND GENERAL SAFETY RULES***



# A01

## INTRODUCTION

With this manual Platform Basket wishes to provide operators with the directions and information necessary for the correct use of the aerial platform and its routine maintenance for the purposes of ensuring the best performance and longest life of our product.

The aerial platform leaves our factory after all the electrical and mechanical components have been inspected and with a full tank of hydraulic oil.



# A02

## MACHINE IDENTIFICATION

The machine identification plate is fixed on one side of the machine.

The following specifications are stamped on the plate:

1. Model
2. Serial number
3. Year of manufacture

and other technical information regarding the machine.



### WARNING

**For any requests covered by the guarantee or for spare parts, indicate the model number (1) and the serial number (2).**

**PLATTFORM BASKET** REGGIO EMILIA - ITALIA  
VIA GRANDE, 27 POVIGLIO - TEL 0522 967666 FAX 0522 967667  
www.plattformbasket.com

DESIGNAZIONE DESIGNATION	P.L.E. (Piastraforma di Lavoro Elevabile) M.E.W.P. (Mobile Elevating Work Platform)
MODELLO MODEL	MATRICOLA SERIAL NO.
	ANNO FABBRICAZIONE YEAR MFD
MASSA MACH. WEIGHT	Kg
POTENZA EXTERNAL POWER	KW
PORTATA CAPACITY	Kg
PERSONE N° MAX. NO. OF PERSONS	
ATTREZZATURA MAX. KGS OF EQUIPMENT	Kg
VELOCITA' MAX VENTO MAX WIND SPEED	m/s
INCLINAZIONE MAX MAX INCLINE	°
SPINTA MANUALE MAX MAX MANUAL FORCE	daN

CE

LWA

dB



















880179



## GENERAL SAFETY RULES









Most of the accidents that occur at work are due to negligence in the maintenance or operation of the machine.

It is therefore necessary to read this manual so as to be able to operate in the greatest possible safety and always maintain the machine in a state of efficiency.

-  Maintain a distance of more than 5 m from live electrical cables.
-  Maintain a distance of at least 2 m from areas with large level differences (ditches, rough or steep ground, etc...)
-  Ensure that there is enough fuel to avoid a forced stop of the machine.
-  Wear a safety helmet and safety belt connected to the special hook in the basket.
-  The handles and running boards must be kept clean of mud, oil, grease and other substances.
-  It is forbidden to load the platform when it is in a raised position.
-  It is forbidden to use the platform for lifting loads.
-  Overloading, lifting sideways, sudden shocks, brusque and sudden movements of the basket are forbidden.
-  The machine can only be used on ground that is solid enough for all four stabilizers to be set on the ground.
-  Never use the machine without the stabilizers correctly opened, set on the ground and without the microswitch permission. Is recommended to lift the tracks off the ground at least 10 cm.
-  Before each work session check the passive and active safety measures.
-  The machine may be used only and exclusively when in good working order.
-  The operator in the basket must be assisted by a suitably trained person on the ground.
-  It is forbidden to get on or off the machine when it is being controlled from the ground.
-  It is forbidden to remove, except for the purposes of maintenance, the protective panels and/or casings
-  Never open the motor compartment without previously cutting off the current from the control panel on the ground.
-  When the batteries of the machine are being used remember that only one illuminated LED (red) of the battery charge indicator means that 15 minutes of autonomy remain. Avoid completely running down the batteries.
-  In the area under the working range of the basket there must be no obstacles or causes of danger to the descent of the basket.
-  Ensure that nobody stops in the area under the working range of the platform and if necessary block their access.



## GENERAL SAFETY RULES

-  It is forbidden to leave the machine in a state other than the rest position and without first removing the keys from the control panel.
-  It is forbidden to use the machine when there is lightning or when weather conditions are likely to produce lightning.
-  Before boarding the basket ensure that it is horizontal and if necessary adjust it by means of the special controls.
-  It is forbidden to use the machine where the wind speed is greater than 12 m/s.
-  Never move over a slope or on ground that could give way.
-  In conditions of poor visibility it is forbidden to use the machine as it is not provided with its own illumination.
-  It is forbidden to drive the machine on roads open to traffic. The machine is not homologated for such use.
-  It is forbidden to use the machine if it is inclined at more than 1° from the horizontal
-  Do not stand under the stabilisers when they are moving.

An operator must not accept operative responsibility unless adequate training has already been given by competent authorized personnel.

Before commencing operation check the work area for overhead electrical power lines, other machinery such as bridge cranes, machinery operating on the road or rails and building equipment.

Before starting work the operator and the person in charge must take suitable precautions in order to avoid known dangers.

Do not operate the machine unless maintenance has been done in compliance with the specifications and the expiry dates indicated by the manufacturer.

Ensure that daily inspections and checks on correct working are carried out before using the machine.

Check that there is enough space above, beside and under the platform when lifting, lowering, rotating the boom or when using the telescopic extension.

Ensure that the operators of other overhead or ground machinery are aware of the presence of the aerial platform. Switch off the current to aerial cranes. If necessary place obstacles on the ground.

Do not push or pull the machine or other objects using the telescopic mechanism of the boom.

Do not leave components on the railings of the basket without Platform Basket's approval.

Never use the boom other than for moving personnel, their tools and equipment to the work position.

Never exceed the nominal capacity of the platform. Consult the load diagrams shown in this manual. Place loads evenly on the floor of the basket.



## GENERAL SAFETY RULES

Never work with a machine in poor working condition. If there should be a break down, stop the machine, place a CLEARLY VISIBLE sign and advise the personnel in charge.

Sudden or acrobatic movements must not be done on the basket.

The operator is prohibited to move between the basket and a structure outside the machine, machine stability could be jeopardised. Staff and equipment must enter and exit the basket only when the same is on the ground.

Never use ladders or steps, or similar objects on the basket or under the machine in order to obtain additional reach for any reason.

When moving about or working on the basket both feet must be firmly placed on the bottom of the basket.

Never walk on the boom to reach the basket or to leave it.

If the boom or the basket is trapped with one or more stabilizers raised from the ground, all the personnel must be removed from the basket before setting about freeing the machine. If necessary use cranes, forklift trucks or other equipment to remove personnel and stabilize the machine.

The operator is responsible for preventing personnel on the ground from using the machine controls and warning them not to work, walk or stop under the boom or the basket. Cordon off the machine at ground level if necessary.

When the machine is to be relocated, check that there are no people, holes, gutters, sudden changes in ground level, obstructions, debris and covers that may hide holes or other hazards.

Do not move the machine on gradients higher than those indicated in the technical specifications.

Never move the machine with the arm raised,

To prevent the machine from toppling over do not drive over soft or uneven surfaces.

Ensure that the conditions of the ground are adequate to sustain the maximum load for the stabilisers and if necessary improve the supporting surface using strong wooden planks.

Do not drive the machine near to ditches, loading bays or other changes in ground level.

When relocating the machine check that there are no obstructions around or above the machine while it is in motion.

Make sure you know the stopping distances for both the high and low gears.

Where visibility is obstructed call for an assistant and use the acoustic warning signal.

When the machine is moving, keep all non operative personnel at least 2 metres away.



## PREPARATION AND INSPECTION

### GENERAL PREPARATION

This section provides the personnel responsible for making the machine ready and for its entry in operation with the information necessary and lists the checks that are to be done before operating the machine. It is important that the information given in this section is read and understood before using the machine. Ensure that all the necessary inspections have been done with positive outcomes before using the machine. These procedures have the purpose of lengthening the working life of the machine and guaranteeing its safety.



#### **IMPORTANT**

***Since the manufacturer is unable to exercise any direct control over the inspections on the spot and maintenance work, these activities fall under the exclusive responsibility of the owner and the operator.***

### MAKING READY FOR USE

Before using a new machine it is necessary to inspect it carefully for any evidence of damage sustained during shipment and then to give it routine inspections as indicated in the section "Inspections to be done routinely and on receiving the machine".

During start up and initial operation, the machine must be checked carefully for hydraulic fluid leaks. Check that all the components are secured in position.

The activities for making the machine ready for use come under the responsibility of personnel in charge. Make ready requires common sense (for example the telescopic boom should extend and retract without encountering obstacles and the brakes should work correctly) combined with a series of visual inspections. The compulsory requirements are listed in the section "Daily visual inspections".

It is necessary to verify that the directions listed in the sections "Inspections on receipt", "Routine Inspections" and "Daily working order check" have been followed.

### INSPECTIONS TO BE DONE ROUTINELY AND ON RECEIPT

#### **NOTE**

***Annual inspection must be done no more than 13 months after the previous annual inspection. The inspection must be carried out by qualified personnel who have experience with our products.***

The following list systematically outlines the inspection procedure aimed at detecting parts that are defective, damaged or incorrectly installed. The list indicates the components to be inspected and the conditions to be examined.

Regular inspections should be done after every 3 months or 150 hours of use, whichever expiry comes first or at closer intervals where environmental conditions or heavy duty and frequency of use require.

This list is also applicable for machines placed in storage or those exposed to severe or changeable climates and must be carefully followed.

These inspections must also be done after maintenance work has been carried out.

### FRAME

- 1 - Check that the belts are not worn or loose, that all parts and bolts are in position and tight.
- 2 - Check that the stabilizer are locked into position, that they do not show signs of damage and that the hydraulic pipes do not leak.



## PREPARATION AND INSPECTION

- 3 - Check that the cylinders for the stabilizer feet are tightened in position, do not show evident signs of wear and that the hydraulic piping shows no leakage.
- 4 - Check that the microswitches in the stabilizer feet and the cylinder pressure switches (if any) are in position and tight.
- 5 - Check that the solenoid valves and hydraulic tubes are not damaged or leaking and that they are secured in position.  
Check the electrical voltage and make sure there are no traces of corrosion on the electrical connections.
- 6 - Check the drive gears, electrical or hydraulic motors, brakes and any hydraulic tubes present for damage or leaks.
- 7 - Check that the ground controls do not have loose or missing parts and that all parts are locked in position. Check the voltage in the electrical connections, make sure that there are no traces of corrosion or exposed wires. Ensure that all the switches work properly.
- 8 - Check the oil level in the drive gears (if necessary contact the service personnel for assistance).

---

### NOTE

***The drive gears must be half full of lubricant oil.***

---

- 9 - Check the batteries (if any), ensuring that the bleed valves are not loose or missing, that the electrical connections are secure and are not corroded and that the electrolyte level is correct.  
Add only distilled water to the batteries.
- 10 - Check that the tank and hydraulic pipes are not damaged or leaking and that the refill plug is locked in position.

---

### NOTE

***Platform Basket recommends that the hydraulic oil filter be replaced after the first 50 hours of operation and every 300 hours thereafter, unless exceptional working conditions require more frequent replacement.***

---

- 11 - Check all electrical cables for damaged or missing parts.
- 12 - Check the motor pump and accessories, ensuring that they are not damaged, parts are not loose or missing and that they are locked in position.  
Check that the electrical cables are tightly secured, that there are no traces of corrosion or damage to the electrical wire insulation and protection.
- 13 - Check all the access doors for damage and that the locks and hinges work correctly and are secured in position.
- 14 - Check that the fuel lines are not damaged or leaking and that they are secured in position.





## PREPARATION AND INSPECTION

### TURRET

- 1 - Check the turret for damage, loose or missing parts and that it is locked in position.  
Check that the rotation gears and its brake do not show signs of damage, loose or missing parts, that the hydraulic pipes and the component housings do not show signs of leaks; check that the slewing gear is not worn.
- 2 - Check the slewing ring for damage, wear, lubricant and for loose or missing bolts.
- 3 - Check that the solenoid valves and hydraulic tubes are not damaged or leaking and that they are secured in position.  
Check the electrical voltage and make sure there are no traces of corrosion on the electrical connections.
- 4 - Check the voltage in the electrical connections, make sure that there are no traces of corrosion or exposed wires.  
Ensure that all the switches work properly.
- 5 - Check that the securing bolts of all the pins are tightened in position and do not show signs of wear.
- 6 - Check that all the joints of moving parts are lubricated.
- 7 - Check that the hydraulic directional control valve and its tubes are not leaking or damaged.

### BOOMS

- 1 - Check that the booms, cylinders and pins are locked in position and do not have damaged or missing parts.
- 2 - Check that the securing bolts of all the pins are tightened in position and do not show signs of wear.
- 3 - Check that the hydraulic pipes and electrical cables are secured in position and do not have damaged or missing parts.
- 4 - Check all the bushings for signs of wear or damage.
- 5 - Check that all the joints of moving parts are lubricated.
- 6 - Check that the sliding blocks have no visible signs of damage, missing parts and that they are locked in position.
- 7 - Check that the chains (if any) of the sliding parts have no signs of damage or missing parts and that their tension is correct.

### BASKET

- 1 - Check that the basket and the control panel are in position and that there are no damaged, loose or missing parts.
- 2 - Check that the switches and control levers are in the off position and that they return to off position when released and do not have any damaged, loose or missing parts. Check that they are working correctly.
- 3 - Check that the switches, control levers and electrical connections are not live and that there are no traces of corrosion.  
Check that all the cables are not defective or damaged.  
Ensure that all the switches work properly.
- 4 - Check that the swivel system of the platform is locked in position, well lubricated, works correctly and is not damaged.  
Check that the hydraulic pipes are secured in position and that they are not damaged or leaking.



## PREPARATION AND INSPECTION

5 - Check that the hydraulic directional control valve and its tubes are not leaking or damaged.

---

### NOTE

***Check that all the signs DANGER, WARNING, INSTRUCTION applied all over the machine are in position and legible.***

---

### BOLT AND SCREW TIGHTENING

The tightening torque table (see the pages specified) consists of standard torque values, based on the diameter and the class (hardness) of the screws; this also establishes the torque values with and without lubricants according to the practice recommended by the factory.

This table is provided for the purpose of helping the user or the operator if the need should arise for immediate adjustment during an inspection or operation so that the maintenance service personnel are informed.

Using the tightening torque table in combination with the index of the points to be tightened shown in the chapter entitled "Maintenance" will improve the safety and performance of the machine.

### DAILY VISUAL INSPECTION

Inspection on workdays before starting up the machine comes under the responsibility of the operator and the user.

Operators and users are advised to inspect the machine before use, even if the machine has already been used by another user/operator.

This daily visual inspection is the best inspection system.

These checks must also be made after maintenance has been done to the machine.

In addition to the daily visual inspection, make sure that the following operations are included as a part of the daily inspection procedure:

- 1 - General cleaning  
Check that all the weight-bearing surfaces are free of spills of oil, fuel, hydraulic oil, mud and foreign bodies. Check the general cleanliness.
- 2 - Plates  
Keep all the plates showing information and control labels clean and visible. To keep them visible it is advisable to cover them when spraying paint or sand blasting.
- 3 - Owner's manual  
Ensure that a copy of this manual is kept in the special container.
- 4 - Machine logbook  
Ensure that notes are kept, or even better a logbook for the machine; ensure that it is kept up to date and that nothing is left in doubt, as this could reduce the safety of the machine.
- 5 - Begin each working day with the batteries charged and/or a full tank of fuel.



### BEWARE

***To avoid injury, do not operate the machine unless all breakdowns have been repaired.***

***The use of a defective machine constitutes a violation of the safety rules.***

***To avoid injuries ensure that the electrical current is switched off during the daily visual inspection.***

---



## PREPARATION AND INSPECTION

### NOTE

***Check visually and manually that the safety micro-switches are in position and that they are working correctly.***

- 6 - Check that the brakes work correctly when the machine is moving on a slope with gradient not exceeding the specification in the technical data, and stop the machine.

### NOTE

***After changing the oil on new and recently overhauled machines and all those which have had the hydraulic oil changed, operate all the movements for at least two full cycles and check the oil level in the tank again.***

- 7 - Ensure that all the parts requiring lubrication are given maintenance.  
Refer to the specific pages for the methods to be adopted.

### GENERAL INSPECTION

Begin the visual inspection from the number on the list shown below. Continue to check the condition of each part indicated in the list of daily visual inspection checks.



### BEWARE

***To avoid injury, do not operate the machine unless all breakdowns have been repaired.***

***The use of a defective machine constitutes a violation of the safety rules.***

***To avoid injuries ensure that the electrical current is switched off during the daily visual inspection.***

### NOTE

***Do not underestimate the importance of inspecting the base of the frame.***

***Checking this area often reveals conditions that can cause serious damage to the machine.***

- 1 - Basket overall - No loose or missing parts; no damage visible; the clevis pins and/or trunnions should be locked in position; the pedal switch should be in good working condition, should not have been modified, deactivated or blocked.
- 2 - Control panel on the basket - The switches and control levers should be in neutral and in the correct position; no loose or missing parts; no damage visible; all labels and plates should be present, intact and legible; all control signs should be legible.
- 3 - Levelling cylinders - No damage visible; the trunnions should be locked in position; the flexible pipes should have no visible damage or traces of leakage.
- 4 - Booms / lifting cylinders and extension cylinders - No damage visible; the trunnions should be locked in position; the flexible pipes should have no visible damage or traces of leakage.
- 5 - Limiter micro-switches - Micro-switches should be in good working order; no damage visible.
- 6 - Brakes, gears, drive motor - No damage visible; no signs of leakage.
- 7 - Track assembly drawing - Notched wheel correctly positioned and tight ; no nuts, bolts or screws should be loose or missing; no damage visible; tracks in order.
- 8 - Hydraulic oil filter - The filter should be correctly locked in position; no damage visible; no signs of leakage.
- 9 - Cover panels - Covers should be correctly secured in position; no loose or missing parts.
- 10 - Control solenoid valves - No loose or missing parts; no signs of leakage; no electrical cables or flexible tubes should be unsupported; no electrical cables should be damaged or broken.



## PREPARATION AND INSPECTION

- 11 - Fuel feed - Fuel tank cap should be locked in position; there should be no visible damage to the tank and no sign of leakage; correct level.
- 12 - Ground controls - Switches should be working; no damage visible; labels should be in place and legible.
- 13 - Hydraulic oil tank - The oil level should be correct (check the level when the oil is cold, the components are not moving and the machine is in the rest position); the cap should be locked in position.
- 14 - Batteries - The electrolyte level is correct; electrical cables are secured without visible signs of damage or corrosion.
- 15 - Motor air filter - Correctly locked in position; no loose or missing parts; no damage visible; clean air filter.
- 16 - Motor oil - Correct oil level on the dip stick; fuel tank cap should be locked in position.
- 17 - Hydraulic pump - No loose or missing parts; no signs of leakage.
- 18 - Exhaust pipe and silencer - Correctly locked in position; no signs of leakage.
- 19 - Slewing ring of the turret - No nuts, bolts or screws should be loose or missing; no damage visible; appropriate lubrication; no signs of loosening between the bearing and the structure.
- 20 - Swivel motor and gears - No nuts, bolts or screws should be loose or missing; no damage visible; appropriate lubrication.
- 21 - Basket rotation cylinders (if present) - No damage visible; flexible pipes should not be damaged and should not leak.

### DAILY WORKING CHECKS

Once the visual inspection has been completed, it is necessary to do a working check of all the systems in an area free of ground and aerial obstructions.

First use the ground controls and check all the functions operated by these controls. Then use the controls on the basket to check all the functions operated from this position.



#### **BEWARE**

***To avoid serious injuries, do not operate the machine if any one of the controls that operate it does not return to its off or neutral position when released.***



#### **BEWARE**

***To avoid collisions and injuries if the machine does not stop when a control is released, remove the foot from the pedal switch (if present) or use the emergency stop button to stop the machine.***

#### **NOTE**

***NEVER move the machine while the arm is raised from the resting position.***

- 1 - Check that the "angle/extension" limiter (if present) works normally.  
Lower and raise the booms of the machine.  
Check that the operation is correct and without obstacles.

#### **NOTE**

***Carry out the checks on the ground controls first and then the basket controls.***



## PREPARATION AND INSPECTION

- 2 - Raise, extend, retract and lower the booms.  
Check that the operation is normal and without obstructions.
- 3 - Extend the telescopic boom so that it moves from the retracted position to the extended position and vice versa a number of times with different lengths of extension.  
Check that the telescopic mechanism works correctly and without obstruction.
- 4 - Rotate the turret to the left and then the right by a minimum of 45°.  
Check that the rotation occurs without obstruction.
- 5 - (Optional) Call for the help of an assistant to check the “frame not level” indicator on the control panel and compress one of the three support springs of the inclination transducers.  
If the indicator does not light up, stop the machine and refer to an authorized technician of the manufacturer before operating the machine.
- 6 - Check that the basket automatic levelling system works correctly during raising and lowering of the boom.
- 7 - Ground controls  
Rotate the general key switch to the OFF position. None of the controls should be enabled, not even the controls in the basket.

### MAINTENANCE OF THE BATTERIES

To avoid injury caused by explosion, do not smoke near the batteries or bring a naked flame or a source of sparking close during maintenance work.



#### **BEWARE**

***Always wear protective goggles when doing maintenance on the batteries.***

- 1 - The batteries do not need maintenance except for the occasional cleaning of the terminals as described below.
- 2 - Remove the cables from each terminal of the battery one at a time beginning with the negative terminal.  
Clean the cables with a neutral solution (for example: sodium bicarbonate and water or ammonia) and a metal wire brush.  
Replace the electrical cables or the screws in the terminals if necessary.
- 3 - Clean the terminals of the battery with a metal wire brush then reconnect the cables to the terminals.  
Apply mineral grease or vaseline to the surfaces that are not in contact.
- 4 - When all the cables and terminals have been cleaned make sure that the cables are secured correctly and not squashed.  
Close the battery housing cover panel.

### MOTOR PUMP MAINTENANCE

Follow the instructions given in the manufacturer's manual.



# A05

## SIGNS AFFIXED TO THE MACHINE

Hook up point for hoisting the machine.



Hand pump.

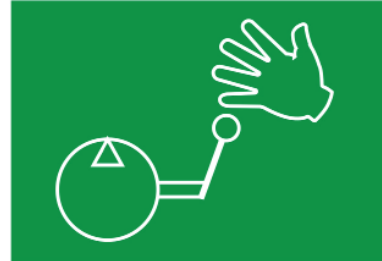

Max load 200 kg



Topping up oil.



DANGER-ELECTRICAL HAZARD



CAUTION

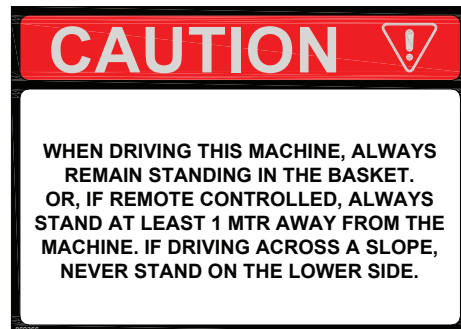

Danger hands and feet cutting.





# A05

## SIGNS AFFIXED TO THE MACHINE

### General safety rules



### Compulsory safety wbelts.



### Read the use and maintenance manual.





# A05

## SIGNS AFFIXED TO THE MACHINE

Not walkable area.



Tools - electric pump.

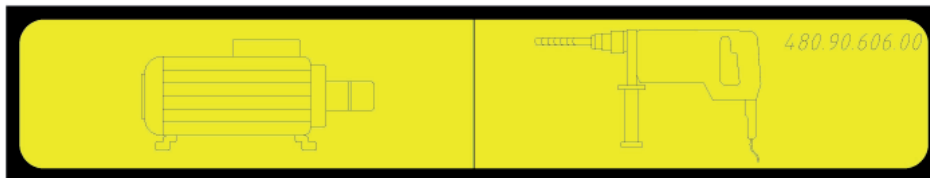

220 VAC label.



Heat source.







# A05

## SIGNS AFFIXED TO THE MACHINE

Diverter valve.

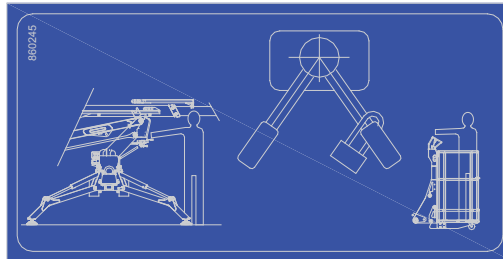

Emergency procedures.

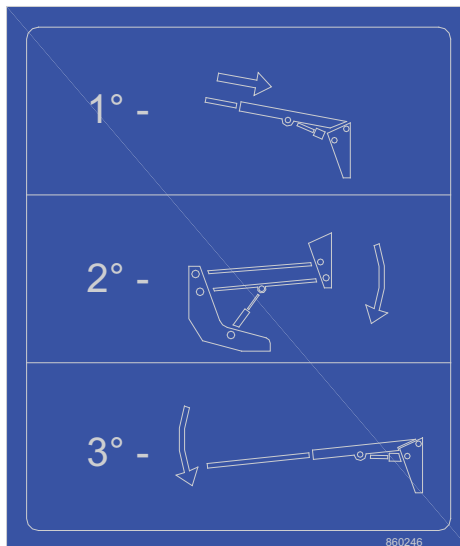

Battery switch.



Max load upon one stabilizer.

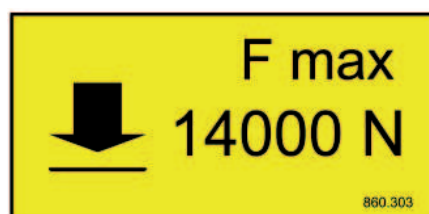



## QUALIFICATION OF OPERATING PERSONNEL

The personnel using or operating the machine must be competent and meet the following requirements:

### **PHYSICAL**

Good eyesight, hearing, co-ordination and the ability to safely carry out all the necessary facilities required for use of the machine.

### **MENTAL**

Ability to understand and apply the established safety standards, precautions and rules. Personnel must be attentive, use good judgment for personal safety and the safety of others; they must think about how to carry out the work correctly and responsibly.

### **EMOTIONAL**

Personnel must be calm and able to withstand stress and to use good judgment in regard to their physical and mental conditions

### **TRAINING**

Personnel must have read, studied and understood this manual, any drawings or diagrams enclosed, the plates indicating danger in addition to being specialized and qualified in all the aspects of use and maintenance.

Personnel must have a license (if required by legislation in the country of the client user)



---

## CUSTOMER'S RESPONSIBILITY AND MACHINE CONTROLS

### GENERAL RESPONSIBILITIES

Since the manufacturer of the machine cannot exert any direct control over the applications and operation of the machine, these activities are the exclusive responsibility of the user and co-workers.

### PERSONNEL TRAINING

The lifting platform is a machine intended for use by personnel. As a result it is essential that its operation and maintenance are entrusted only to authorized personnel who have demonstrated that they understand how to use and maintain the machine.

It is important that all the personnel assigned to the unit and responsible for the operation and maintenance of this machine follow a thorough training programme and complete a period of probation in order to become familiar with the operational features of the machine before using it.

Persons under the influence of alcohol or drugs and persons suffering from epileptic fits, dizziness or loss of motor nerve control must not be allowed to use the machine.

#### Operator training

Operator training is based on the following:

- 1 - Use and limitations of the controls in the basket, those on the ground and the emergency controls.
- 2 - Knowledge and comprehension of this manual and the control signs, instructions and warnings affixed to the machine.
- 3 - Knowledge of all the work safety rules imposed by the employer and the laws in force, including training in regard to the recognition and prevention of potential dangers present in the place of work, with special attention to the specific job to be carried out.
- 4 - Use correct of all the compulsory devices for operators safety, particularly the use of the safety helmet and any other safety devices against the falls. Harnesses must always be dresses and hooked to the basket anchoring points.
- 5 - Sufficient knowledge of the mechanical working of the machine to be able to recognize actual or potential break-downs.
- 6 - The best ways to operate the machine in the proximity of suspended obstructions, other moving equipment and where there are obstructions, depressions, holes, sudden dips, etc. in the surface supporting the machine.
- 7 - The safest ways to avoid danger from bare electrical conductors.
- 8 - Any other requirement specific to a given application of the machine.

#### Training supervision

The training must take place under the supervision of a qualified operator or supervisor, in an open area without obstacles until the personnel under training have developed the ability to safely operate the lifting platform in congested areas.

#### Operator's responsibilities

The operator must be informed that he has the responsibility and the authority to stop the machine in the case of a breakdown or other conditions of reduced safety associated either with the machine or the work place and to request instructions from the supervisor or the distributor of the product before proceeding further.

---

#### NOTE

***At the time of delivery of the first unit and, successively, at the request of the user or his personnel, the manufacturer or the distributor will provide qualified personnel to assist in the training of the operators.***

---



## OPERATING POSITIONS

The machine can be driven from the following stations:

- on the basket for one operator;
- on the turret and on the chassis as emergency station
- fixed on the chassis for traslation and stabilization operations.

### NOTE

*Alternatively a radio control station can be fitted on the machine. This solution, supplied as option, enable to drive and stabilize the platform from the radio control panel.*

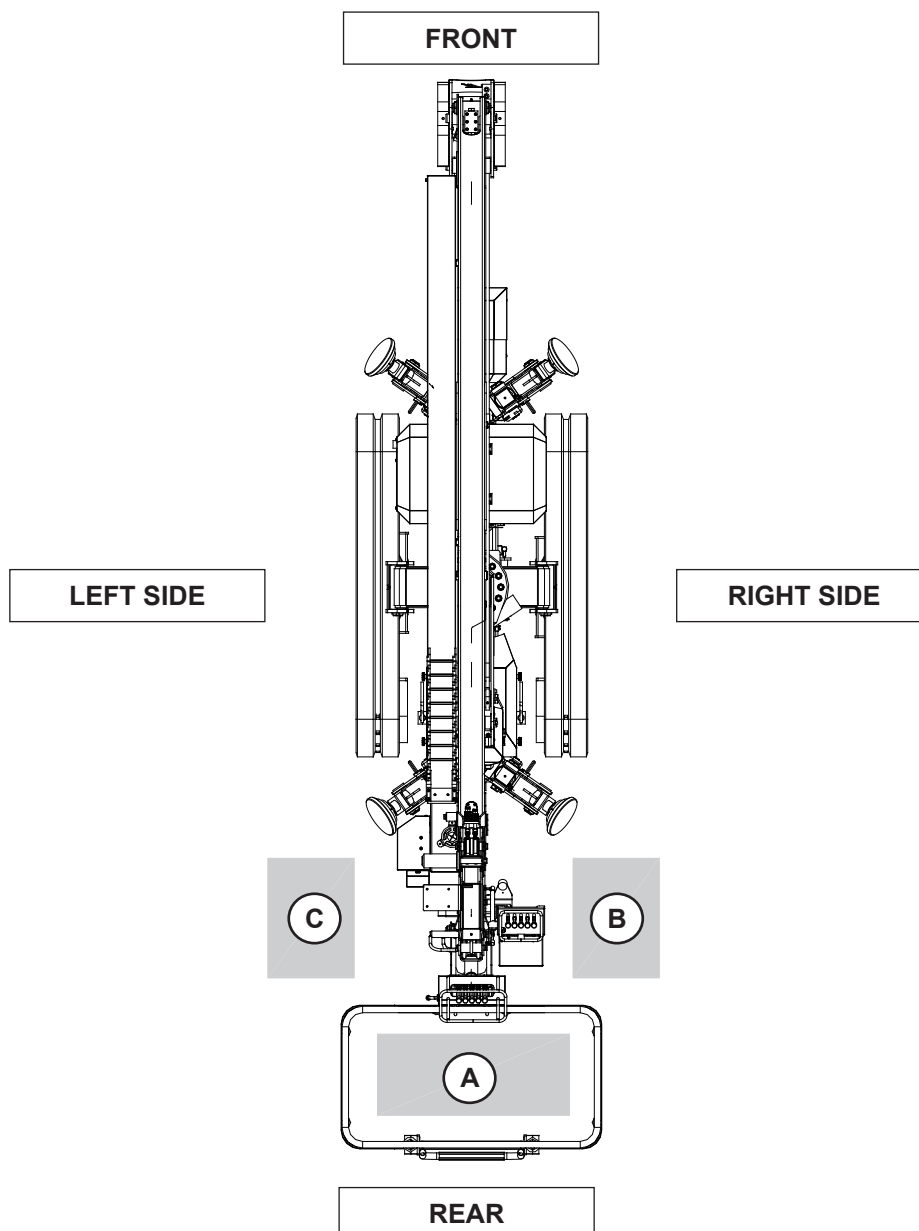



## THE ROLE OF THE OPERATORS

### WORK POST IN THE BASKET

Carry out the normal movements of the machine



#### WARNING

*The operator on the basket must ALWAYS wear a safety belt and must be assisted by an adequately trained person on the ground.*



### GROUND WORK POST

- switch on and switch off the machine at the beginning and end of the work session;
- monitor the instruments on the control panel during work;
- make sure that persons do not enter the work area;
- Carry out manual manoeuvres only in the case of an emergency.

### OPERATOR DUTIES

When the machine is being used, the presence of at least 2 is a compulsory requirement.

One operator must be posted **on the ground** and one operator in the **basket**.

---

**SECTION**

**B**

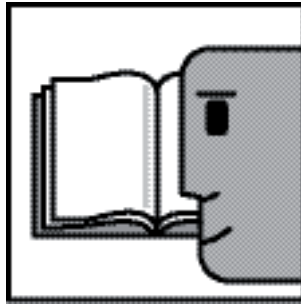

**DESCRIPTION AND USE OF THE MACHINE**

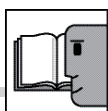

## TECHNICAL INFORMATION

### SPIDER 18.90 PRO OVERALL DIMENSIONS

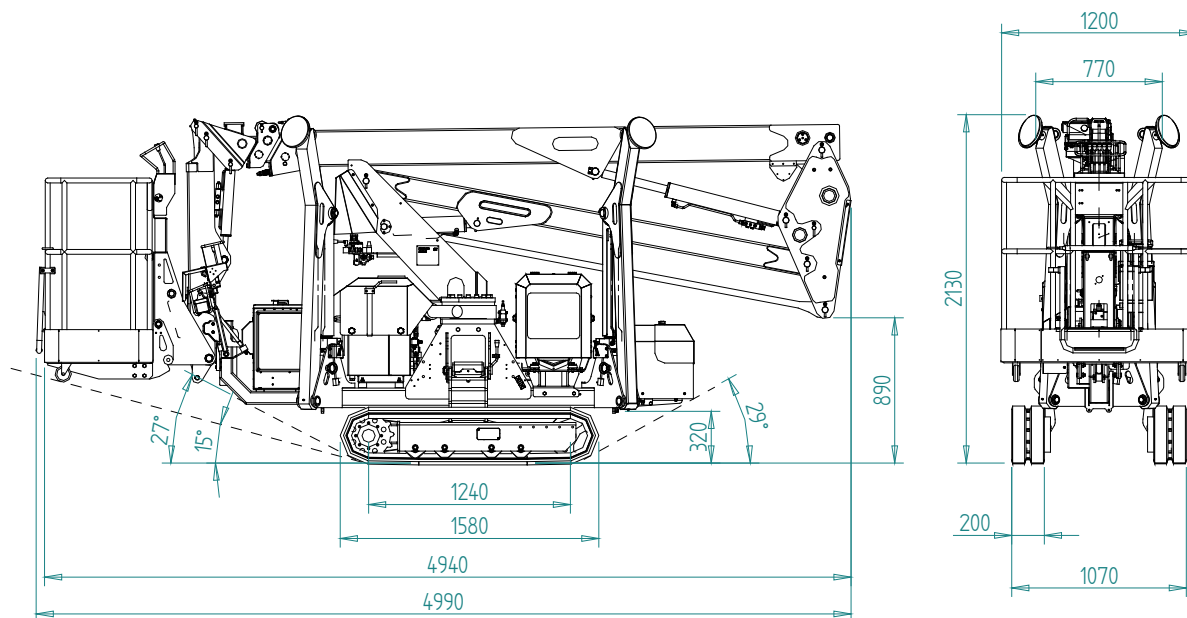

	HONDA	HATZ	KUBOTA
Working height		18.0 mt	
Floor height		16.0 mt	
Side reach (basket edge+0.5 mt)		9.2 mt	
Max basket load		200 kg	
Basket rotation		-	
Turret rotation (NC)		360°	
Jib length		1.35 mt	
Maximum length		4.94 mt	
Maximum width		1.2 mt	
Height at rest		2.13 mt	
Basket dimensions		1.2x0.67 mt	
Translation speed with one speed motors		1.25 km/h	
Translation speed with two speed motors		1.1 / 2.2 km/h	
Electric pump		2.2 kw	
Net installed power	8.2kw@3600rpm	7.5kw@3600rpm	9.9kw@3600rpm
Measured sound power level	102 dBA	104 dBA	102 dBA
Guaranteed sound power level	104 dBA	107 dBA	104 dBA
Sound pressure level	82 dBA	83 dBA	82 dBA
Controls		Proportional	
Maximum gradient		25% -14°	
Tires		tracks	
Hydraulic tank		25 lt	
Fuel tank	6.1 lt	5 lt	11.5 lt
Total weight	2400 kg	2400 kg	2500 Kg
Maximum load on the ground on tracks	0.19 / 0.24 daN/cm <sup>2</sup>	0.19 / 0.24 daN/cm <sup>2</sup>	0.20 / 0.25 daN/cm <sup>2</sup>
Maximum load on the ground on stabilizers	2.11 kN/m <sup>2</sup>	2.11 kN/m <sup>2</sup>	2.2 kN/m <sup>2</sup>
Max force on a stabilizer	16.5 kN	16.5 kN	17.2 kN
Inclinometer		yes	
Maximum inclination		1°	
Electric circuit		12 V	
Battery		55 Ah	
Work with wind at		12 m/s - 43 km/h	
Total transmitted vibration		<= 0.5 m/s <sup>2</sup>	

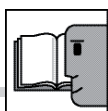

## TECHNICAL INFORMATION

### SPIDER 18.90 PRO OVERALL DIMENSIONS WITH BASKET ROTATION

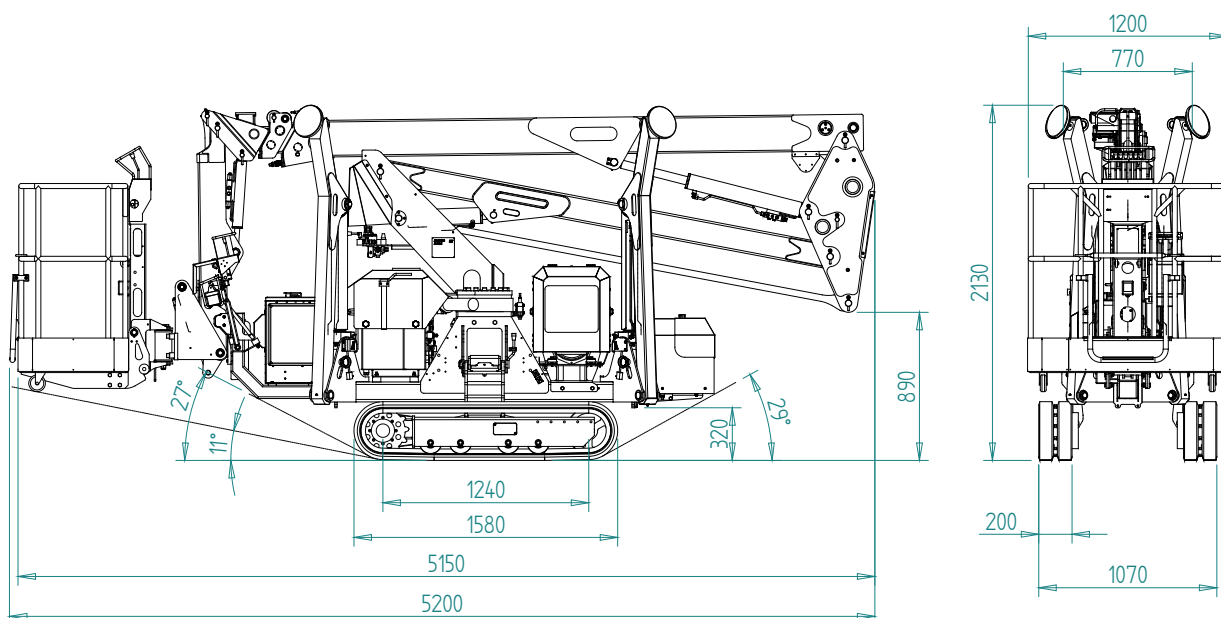

	HONDA	HATZ	KUBOTA
Working height		18.0 mt	
Floor height		16.0 mt	
Side reach (basket edge+0.5 mt)		9.2 mt	
Max basket load		200 kg	
Basket rotation		-70° / +70°	
Turret rotation (NC)		360°	
Jib length		1.35 mt	
Maximum length		5.15 mt	
Maximum width		1.2 mt	
Height at rest		2.13 mt	
Basket dimensions		1.2x0.67 mt	
Translation speed with one speed motors		1.25 km/h	
Translation speed with two speed motors		1.1 / 2.2 km/h	
Electric pump		2.2 kw	
Net installed power	8.2kw@3600rpm	7.5kw@3600rpm	9.9kw@3600rpm
Measured sound power level	102 dBA	104 dBA	102 dBA
Guaranteed sound power level	104 dBA	107 dBA	104 dBA
Sound pressure level	82 dBA	83 dBA	82 dBA
Controls		Proportional	
Maximum gradient		25% -14°	
Tires		tracks	
Hydraulic tank		25 lt	
Fuel tank	6.1 lt	5 lt	11.5 lt
Total weight	2430 kg	2430 kg	2530 Kg
Maximum load on the ground on tracks	0.20 / 0.25 daN/cm <sup>2</sup>	0.20 / 0.25 daN/cm <sup>2</sup>	0.20 / 0.26 daN/cm <sup>2</sup>
Maximum load on the ground on stabilizers	2.14 kN/m <sup>2</sup>	2.14 kN/m <sup>2</sup>	2.22 kN/m <sup>2</sup>
Max force on a stabilizer	16.7 kN	16.7 kN	17.4 kN
Inclinometer		yes	
Maximum inclination		1°	
Electric circuit		12 V	
Battery		55 Ah	
Work with wind at		12 m/s - 43 km/h	
Total trasmitted vibration		<= 0.5 m/s <sup>2</sup>	



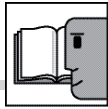

# B01

## TECHNICAL INFORMATION

### SPIDER 18.90 PRO WORKING DIAGRAMS

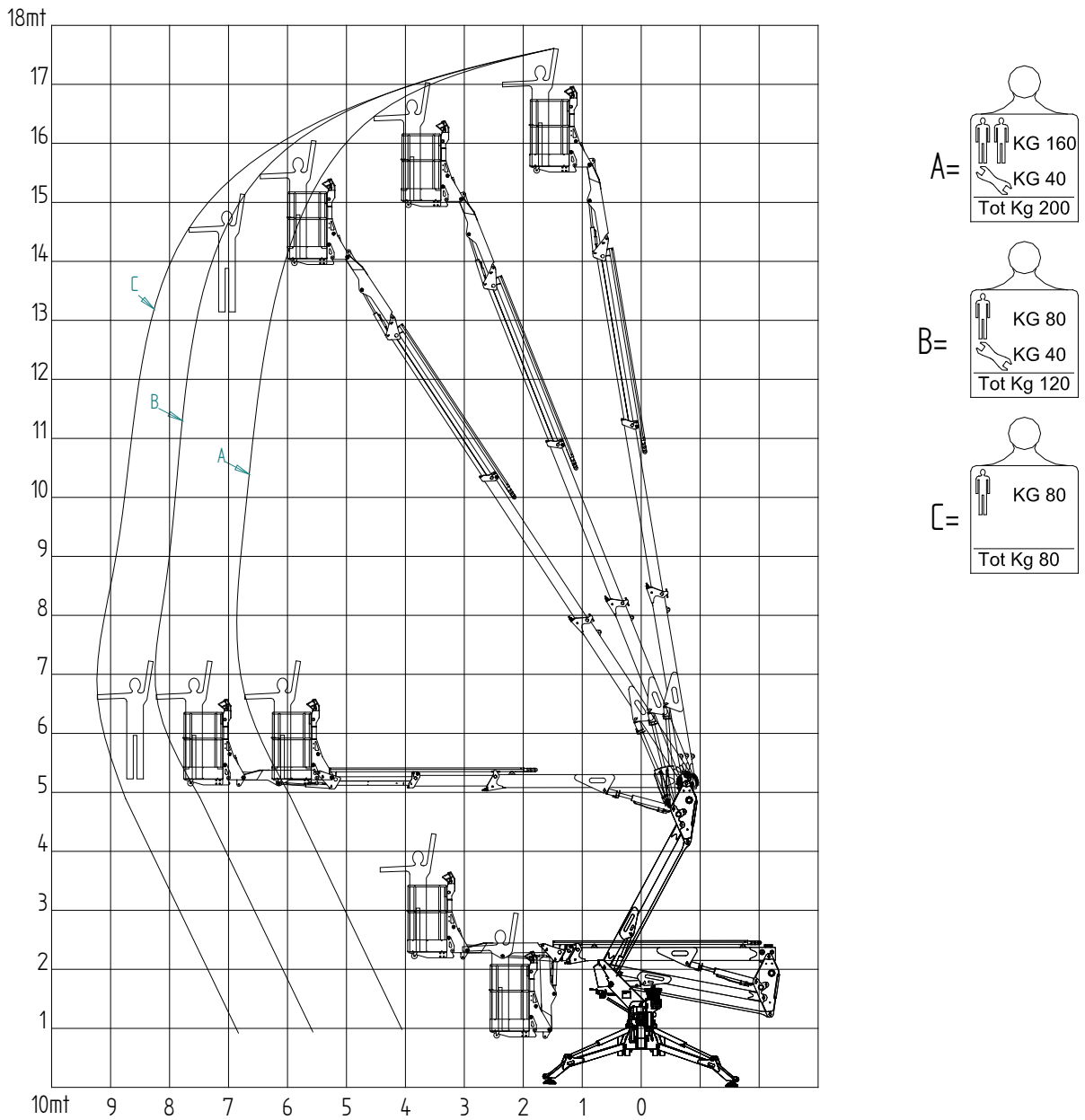

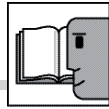

## GENERAL DESCRIPTION



### WARNING

*The model illustrated may be slightly different from the model in possession.*

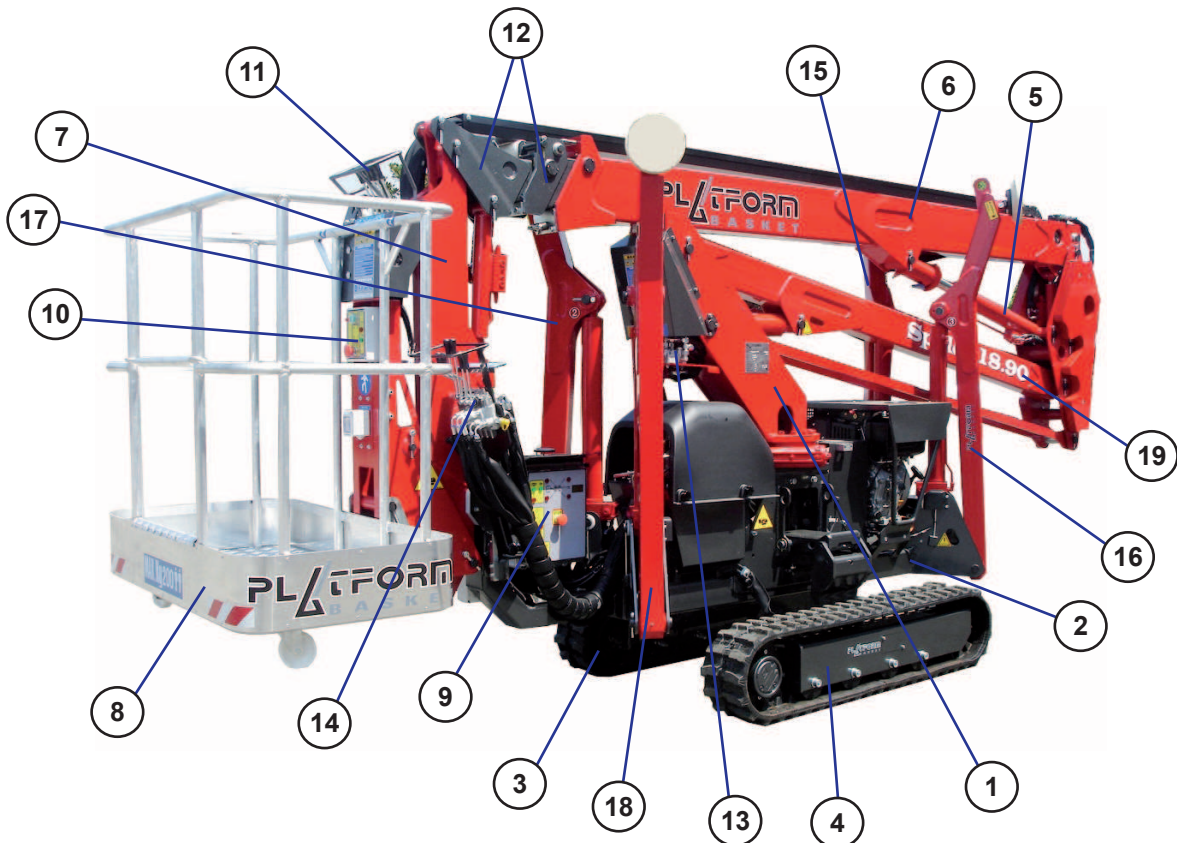

1. Turret
2. Truck
3. Left track (\*)
4. Right track (\*)
5. Telescopic boom lifting cylinder
6. Telescopic boom
7. Jib
8. Basket
9. Ground control panel
10. Basket control panel
11. Control levers in the basket
12. Telescopic element
13. Ground control levers (for the aerial parts)
14. Ground control levers (for movement/stabilisation)
15. Front left stabiliser (4)
16. Front right stabiliser (3)
17. Rear left stabiliser (2)
18. Rear right stabiliser (1)
19. Scissor booms

(\*) The normal driving direction for the self-propelled platform is determined by the basket (8) at the rear.

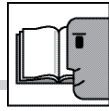

## B02

### GENERAL DESCRIPTION

#### TRUCK

The truck is the support frame for the machine. It houses the drive and power units.

The truck is fitted with tracks .

The machine stabilizers are also installed on the truck.

This machine is equipped with an extensible truck system which allows improved stability and mobility on rough terrain. It is recommended to keep extended the tracks during traslation movement. Section B11 will show how to work during traslation operations.

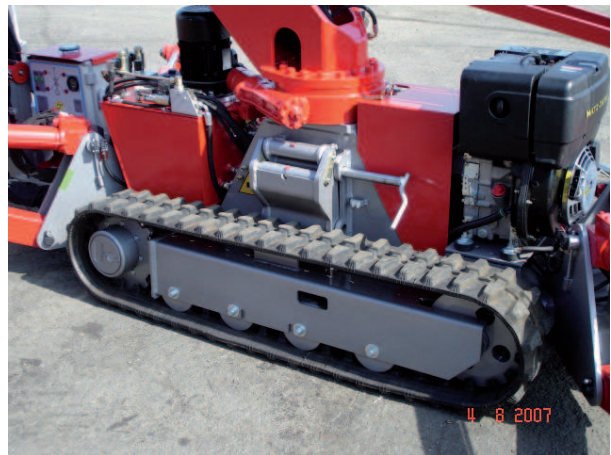

#### POWER ASSEMBLY

All the movements of the self-propelled platform are provided by hydraulic pumps connected to a gasoline engine (1), or a diesel engine upon request, or an electric motor (2) powered at 220 V or 380 V.

For all information regarding the benzine or diesel motor, see the specific manual attached.

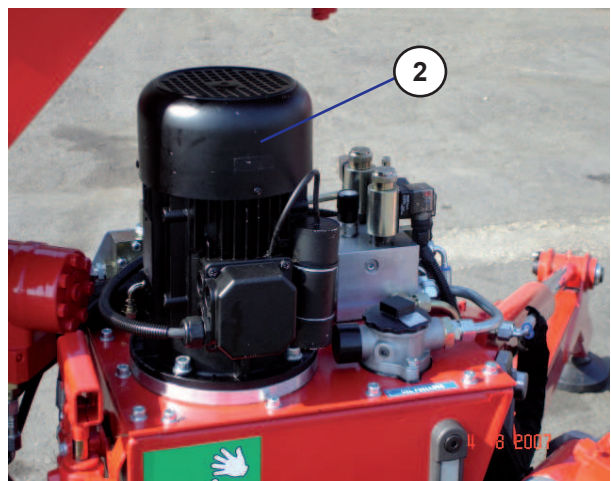
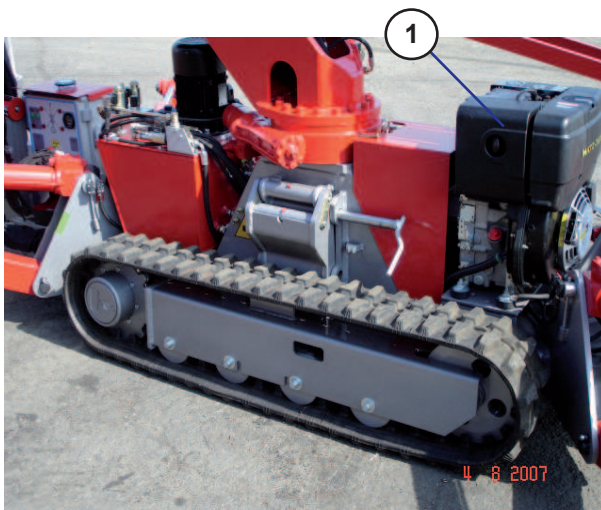

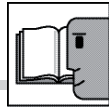

## GENERAL DESCRIPTION

### TURRET

The turret, mounted on the slewing ring, is rotated by a hydraulic gear . This sustains the entire aerial part of the machine (booms/basket).

The ground controls for the aerial part of the machine are located on the side of the turret. These controls are to be used **ONLY** in the case of emergency.



### BOOMS

The telescopic boom (1) has one fixed element and two telescopic elements.

The scissors boom (2) consists of two structures configured in the form of a parallelogram.



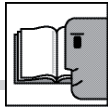

## GENERAL DESCRIPTION

### JIB

The jib consists of two elements in parallelogram configuration and constitutes another point of articulation of the booms.



### BASKET

One or two operators can occupy the basket.

The basket is balanced by a cylinder driven by the telescopic boom.

To facilitate passage of the vehicle through narrow gaps and make it easier to climb ramps, the basket is removable.



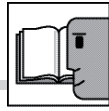

## SAFETY DEVICES

A number of safety devices are installed on the machine for the safety of the operator and the protection of the machine.

### ACOUSTIC SIGNAL / VISUAL SIGNAL

The Buzzer operates every time you are in the condition of driving or moving the stabilizers, so with combustion engine or electric motor ON and with aerial booms completely folded down.

It operates also every time the stabilization set-up doesn't perform well and when at side-reach limit.

It operates to alert the operators against battery discharge, when main key selector is left ON and the platform not in use and not powered for more than 4 minutes.

### EMERGENCY BUTTONS

If pressed, they stop the machine immediately.



### LEVELLING GAUGE

Makes it possible to check that the machine is level.



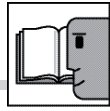

## SAFETY DEVICES

### STOWED MACHINE MICROSWITCH

These microswitches detect when the arm is in the resting position, the turret is aligned with the machine driving direction and stabilizer movement is enabled.



### SAFETY PLATES

See the related paragraph.

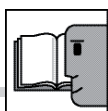

## SAFETY DEVICES

### OUTREACH LIMITER DEVICE

This platform is equipped with an automatic load limiting device.

This pressure sensor automatically stops the platform movements whenever the telescopic boom is extended over the allowed limit. RED lamp pos. "2" starts blinking when platform is near to the envelope outreach limits, the. It lights ON when the platform reach the envelope limit and movements are automatically excluded.

Throughout the extension boom in movement it will be possible to restore the platform movements. (You have to push also the red button 1 during restore the platform movements from cage, until the red lamp 2 switch off).



### IMPORTANT

*Booms outreach depends on load applied in the basket.*

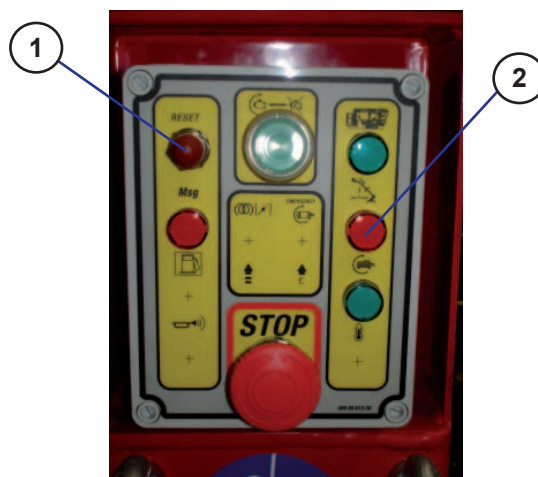

### PUMP AND CONTROLS

In addition to the controls (1) located on the back of the column there is the emergency pump (2) which may be used excluding the solenoid valves (see "Emergency manoeuvres").

Besides the hand pump, upon request another pump can be installed. This pump serves the same function as the motor pump but is powered by the batteries.

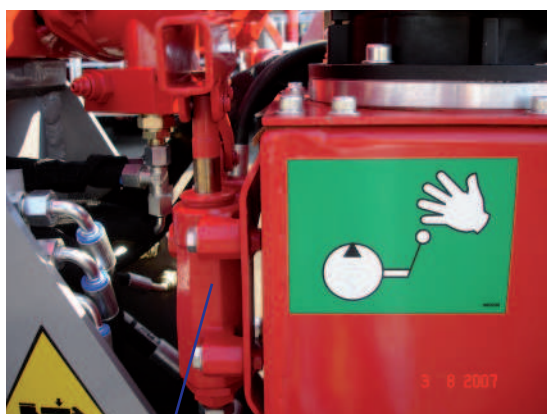

2



1



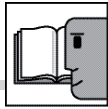

## SAFETY DEVICES

### STABILIZATION MICROSWITCHES

Each stabiliser foot is provided with a microswitch (1) that ensure a condition of stability on the ground.

A series of warning lights signals correct stabilization: when the warning lights (2) go on, the movements related to the aerial part of the machine are enabled.



1



2

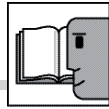

## GROUND CONTROL PANEL

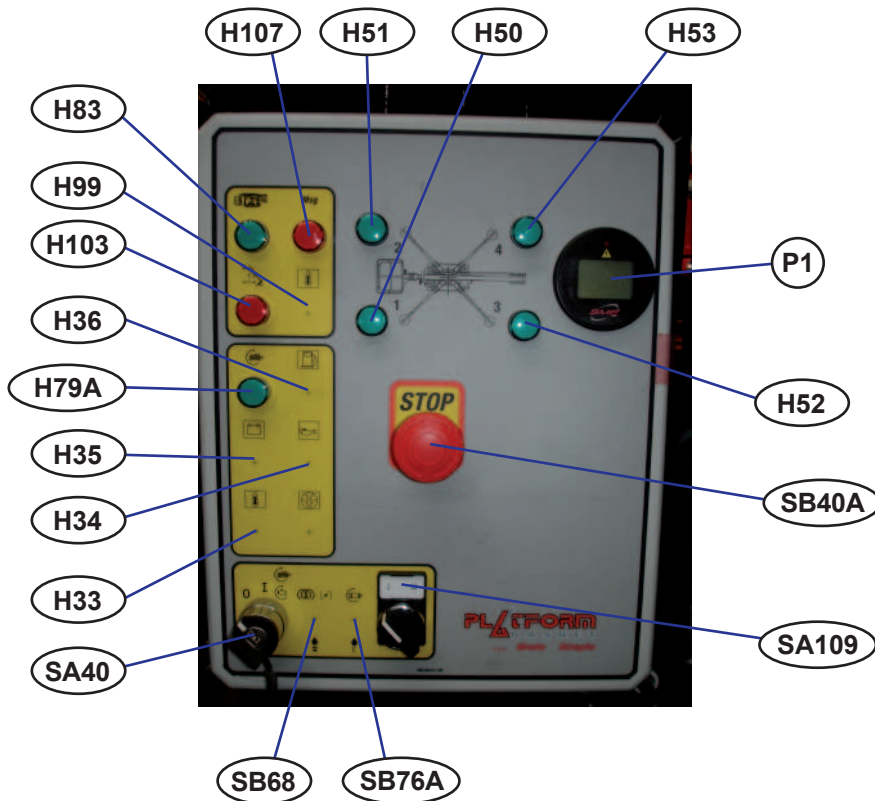

### SA40 Diesel motor start/voltage connection key switch

Three-position selector switch:



(0) The motor pump/electropump is stopped and the voltage is disconnected and cuts off power to the electrical panels of the machine



(I) The motor pump/electropump is enabled and the voltage is connected



(II) The motor pump/electropump is started (the switch is turned to position II only during the start up of the motor, when released it turns to position I). The selection of the electropump is automatic with 220V line connected.

### Ground stabilisers control warning lights(H50-H53)

- Green lamps when "ON" displaying the correct stabilization of each leg when down on ground.

- **H50**  
Rear right stabiliser
- **H51**  
Rear left stabiliser
- **H52**  
Front right stabiliser
- **H53**  
Front left stabiliser



### WARNING

*If a single one of these warning lights goes off, there is a stabilisation fault.*

### H107 Diagnostic RED lamp – Troubleshooting from the electronic board

When the RED lamp blinks, some faults are monitored by the electronic board. The number of flashes allows to understand the type of fault occurred. (Diagnostic recommended for service centers only)

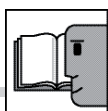

## GROUND CONTROL PANEL

### **H83 Stowed machine warninglight**

This warninglight on signals that the machine is stowed: booms are lowered and packed and are aligned to the longitudinal axe of the machine.

This condition is COMPULSORY to allow stabilization and traslation functions.

### **H99 Temperature sensor indicator (option)**

The lamp when "ON" states the low temperature and do not allow the use of the platform (see section F)

### **H103 Outreach delimeter indicator**

The RED lamp starts blinking when platform is near to the envelope outreach limit. It lights up when the platform reach the envelope limit and movements are automatically excluded.

### **H36 Fuel level indicator**

The yellow lamp monitors the low level of diesel fuel. (it is available with Kubota engine only).

### **HL79A Electropump warninglight**

This warninglight on signals that the electropump is started.

### **H35 Low battery warninglight**

This warninglight on signals low battery recharging. Refer to engine's owner's manual.

### **H34 Engine oil pressure warninlight**

This warninglight on signals insufficient oil pressure in the internal combustion engine. Refer to engine's owner's manual.

### **H33 Engine overheating warninglight**

This warninglight on signals engine overheating. Refer to engine's owner's manual.

### **SB68 Cold start push-button**

The button enables the cold start of the engine. By pushing the button the choke (gasoline engine) or the pre-heating glow plugs(diesel engine) are energized for the time the button is hold pushed. We recommend to hold for some seconds to let the device operating.

### **SB76A Emergency electropump selector (optional)**

The selector starts the emergency electropump.

### **SA109 Double speed selector**

The selector allows to select the tracks drive wheels speed, slow or fast.

### **SB40A Emergency stop button**

With the button pushed in the machine undergoes an emergency stop: all the movements are stopped, electricity is disconnected from all controls and the electrical and motor pumps are stopped.

Reset by turning the button in the direction of the arrows.

### **P1 Hourmeter**

The counter meter records hours and minutes only when the engines, both the endothermic and the electric one, are moving.

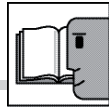

## B05

### A.C. MAINS - BOX & PLUG

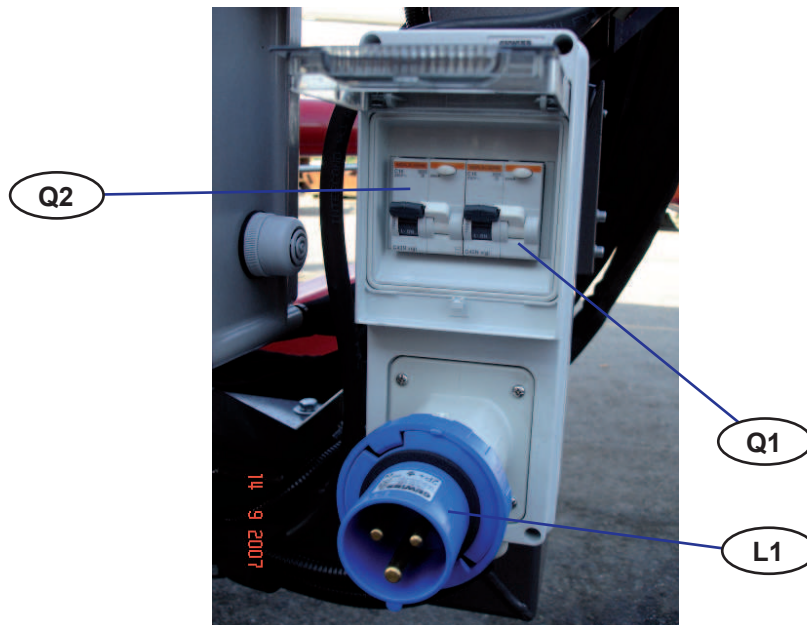

This panel is present when the machine is provided with an electrical pump powered at 220 or when required 220V on cage.

**L1 Connection plug to the electric network**

**Q1 Magneto-thermic switch**

With the switch moved to ON the power is available at the cage

**Q2 Magneto-thermic switch**

With the switch moved to **ON** the electrical pump is enabled.

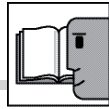

# B06

## CONTROLS FOR MOVEMENT/ STABILISATION

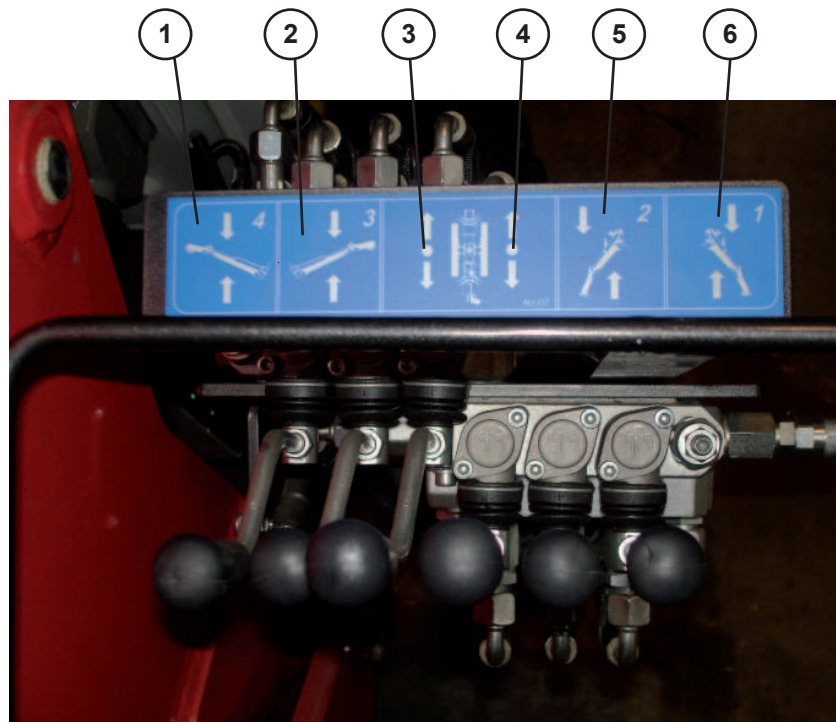

### NOTE

*These controls are enabled ONLY with the aerial part retracted.*

**1 Stabiliser N°4 movement**

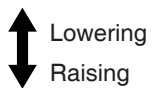

Lowering

Raising

**2 Stabiliser N°3 movement**

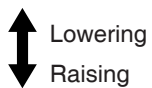

Lowering

Raising

**3 Left track running**

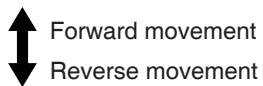

Forward movement

Reverse movement

**4 Right track running**

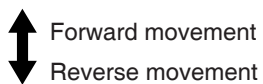

Forward movement

Reverse movement

**5 Stabiliser N°2 movement**

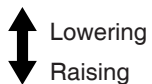

Lowering

Raising

**6 Stabiliser N°1 movement**

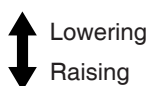

Lowering

Raising

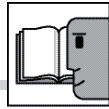

## B06

### CONTROLS FOR MOVEMENT/ STABILISATION



Traslation/stabilization commands are mounted on a mobile chassis. This structure have to be raised only during traslation and stabilization operation. After the correct stabilization of the platform and before start working this chassis must be lowered.



#### **IMPORTANT**

***Avoid using the platform before lower the command-holding structure in order to avoid collisions with other parts of the machine.***

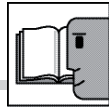

# B07

## GROUND CONTROL STATION AERIAL PARTS (EMERGENCY CONTROLS)



### NOTE

*These controls are enabled ONLY with the lever 1 in the left position.  
 These controls are to be used ONLY in the case of emergency; in fact there is the possibility of blocking the lever 1 using a lock in order to enable only the controls in the basket.*

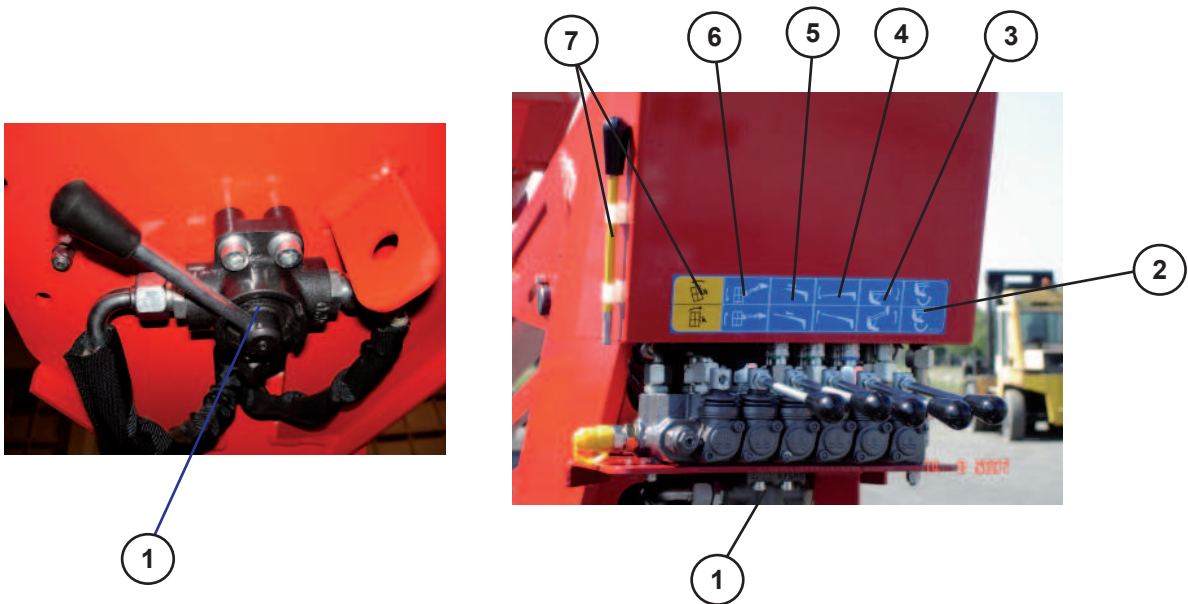

#### 1 Control selection lever



Controls in the basket  
 ground controls

#### 2 Turret rotation



counterclockwise rotation  
 clockwise rotation

#### 3 Scissor boom movement



lowering  
 raising

#### 4 Telescopic boom movement



lowering  
 raising

#### 5 Telescopic boom extensions movement



extension in  
 extension out

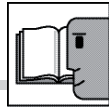

## B07

### GROUND CONTROL STATION AERIAL PARTS (EMERGENCY CONTROLS)

6 **Jib movement**

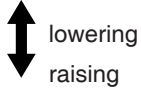

(7) **Basket levelling**

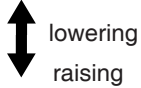

(7) **DANGER**

*This control must ONLY be used in case of lost of basket planarity . Basket leveling set-up shall be done by emergency ground controls (by using the yellow lever stored beside of them)with nobody on-board and with the basket near to the ground.*



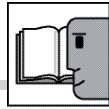

## CONTROL PANEL ON THE BASKET

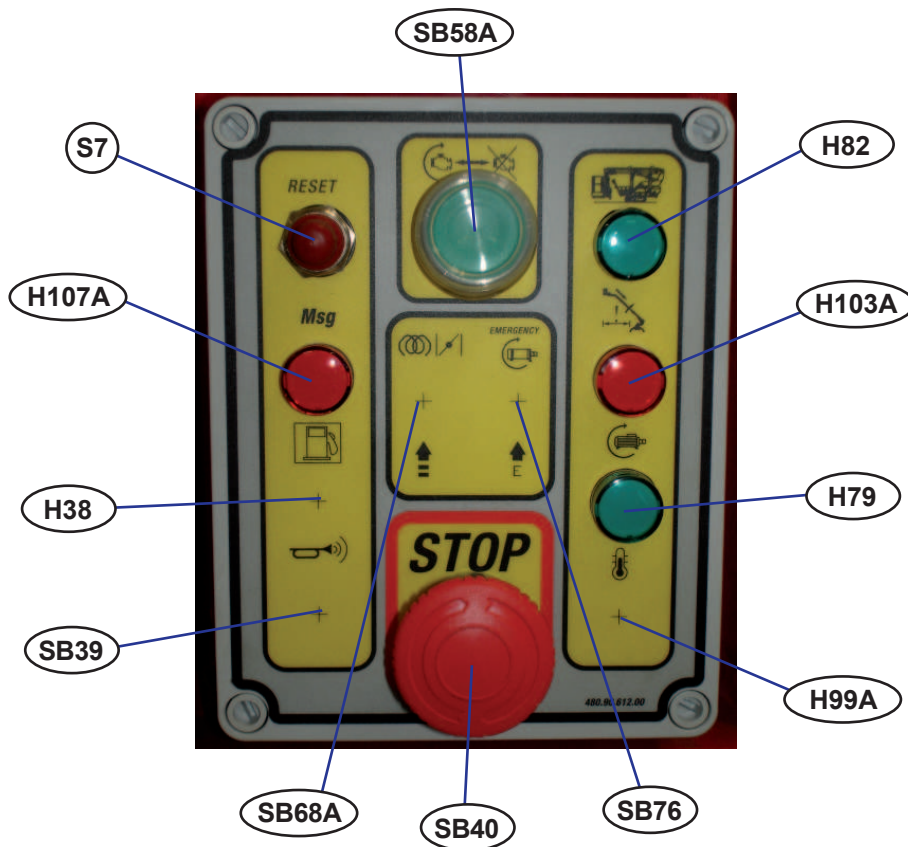

### **SB58 Start/stop button for electropump/motorpump**

With the button pushed in the motor pump or electrical pump is started (depending on the selection made from the ground).

### **S7 RESET side-reach limit - push-button**

With button pressed allow you to go inside with the extension pulling the hydraulic lever on cage when you are at the edge of the working diagram (**H103A** switched on). You need to hold pressed the button until the red lamp **H103A** switch off.

### **H107A Diagnostic red lamp - Troubleshooting from electronic board.**

The lamp when flashing monitors faults occurred to the electric circuit.

### **H38 Fuel level indicator**

The yellow lamp monitors the low level of diesel fuel. (it is available with Kubota engine only).

### **SB39 Horn button (option)**

When pushed the horn sounds (see section F).

### **SB68A Cold start push-button**

The button enables the cold start of the engine. By pushing the button the choke (gasoline engine) or the pre-heating glow plugs(diesel engine) are energized for the time the button is hold pushed. We recommend to hold for some seconds to let the device operating.

### **SB40 Emergency button**

With the button pushed in the machine undergoes an emergency stop: all the movements are stopped, electricity is disconnected from all controls and the electrical and motor pumps are stopped. Reset by turning the button in the direction of the arrows.

### **SB76 Emergency electropump selector (optional)**

The selector starts the emergency electropump.

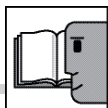

## CONTROL PANEL ON THE BASKET

### **H99A Temperature sensor indicator (option)**

The lamp when "ON" states the low temperature and do not allow the use of the platform (see section F)

### **H79 220V/380V/110V electropump indicator**

The indicator on signals that the machine is connected to the line voltage.

### **H103A Outreach delimiter indicator**

The RED lamp starts blinking when platform is near to the envelope outreach limit. It lights up when the platform reach the envelope limit and movements are automatically excluded.

### **H82 Stowed machine warninglight**

This warninglight on signals that the machine is stowed: booms are lowered and packed and are aligned to the longitudinal axe of the machine.

This condition is **COMPULSORY** to allow stabilization and traslation functions.

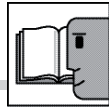

## CONTROL LEVERS IN THE BASKET



### NOTE

*These controls are enabled ONLY after the correct stabilization of the platform.*

**1 Jib movement**

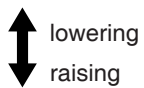

**2 Telescopic boom extension movement**

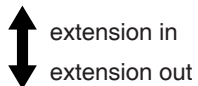

**3 Telescopic boom movement**

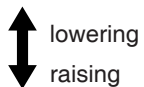

**4 Scissor boom movement**

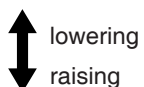

**5 Turret rotation**

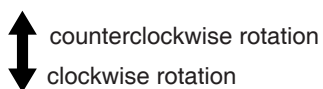

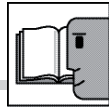

## B09

### CONTROL LEVERS IN THE BASKET (WITH ROTATION)



#### NOTE

*These controls are enabled ONLY after the correct stabilization of the platform.*

#### 1 Basket rotation

↑ clockwise rotation  
↓ counterclockwise rotation

#### 2 Jib movement

↑ lowering  
↓ raising

#### 3 Telescopic boom extension movement

↑ extension in  
↓ extension out

#### 4 Telescopic boom movement

↑ lowering  
↓ raising

#### 5 Scissor boom movement

↑ lowering  
↓ raising

#### 6 Turret rotation

↑ counterclockwise rotation  
↓ clockwise rotation

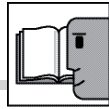

## OTHER DEVICES

### AIR AND WATER SERVICES

On request it is possible to have two intakes for air and/or water installed in the basket. These facilities are connected to a central plant by means of the connections (1).

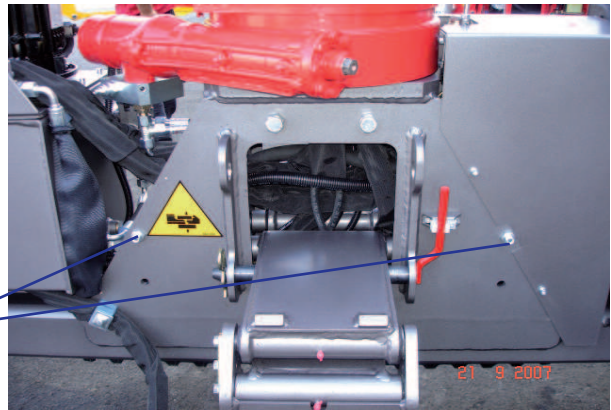
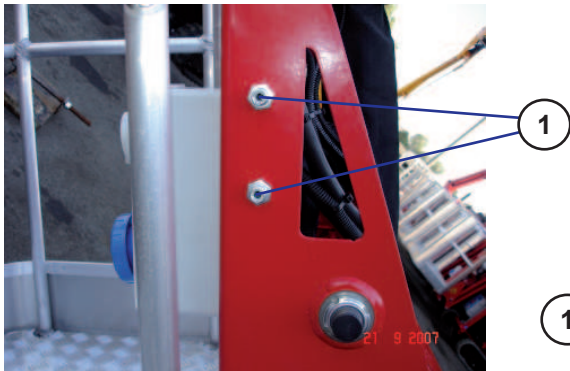

### VOLTAGE IN THE BASKET

On request it is possible to have an electrical socket (2) installed in the basket. This installation is connected to a central plant through the connection (3).

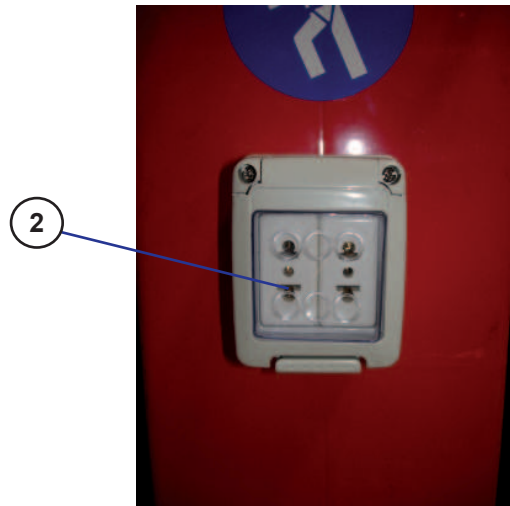
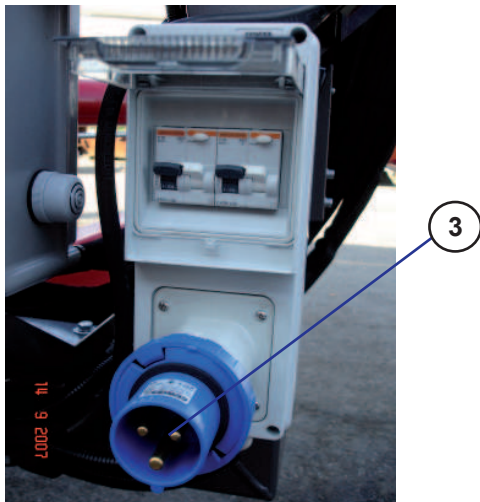

### WORK FLOODLIGHT

On request it is possible to have a floodlight for work (4) installed on the basket. The switch is located directly on the lamp.

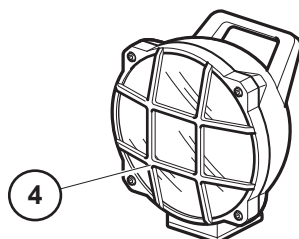

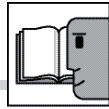

## TRANSPORT / TRASLATION



### WARNING

*This machine is equipped with an extensible track system wich allows improved stability and mobility on rough terrain. It is reccomended to keep the tracks extended during traslation movement.*

### TRACKS EXTENSION

This operation must be done using stabilizers and with stowed platform. Check that the working area is large enough to lower the stabilizers.

Operations that should be done, starting with stowed tracks, are:

- remove the block pin [1] (on both sides of the machine)
- lower completely the stabilizers (keeping distance from tracks)
- replace the pin in the lower center [2] (on both sides of the machine)
- raise the stabilizers

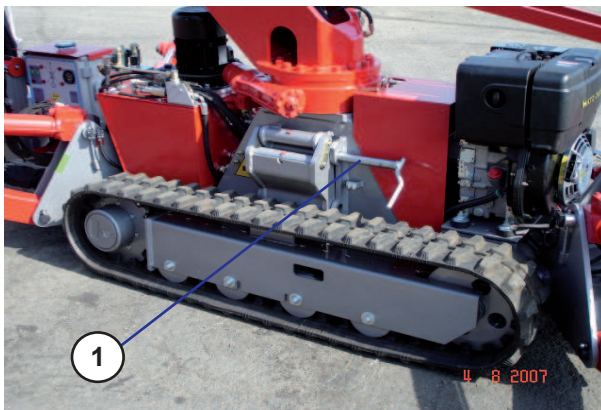

### TRACKS EXTENSION

This operation must be done using stabilizers and with stowed platform. Check that the working area is large enough to lower the stabilizers.

Operations that should be done, starting with extended tracks, are:

- lower completely the stabilizers (keeping distance from tracks)
- remove the block pin(on both sides of the machine)
- raise the stabilizers
- replace the pin in the upper center (on both sides of the machine). In high friction condition between tracks and terrain may be necessary a short traslation path, to arrange the system, before replace the pin in its center.



### BEWARE

*This machine in stowed tracks condition offer a smaller stability during traslation operation. Use the machine with extreme caution in case of strong slopes.*

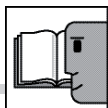

## TRANSPORT / TRASLATION

The machine may be transported on a truck and/or trailer.



### BEWARE

**During transportation, the machine must ALWAYS be secured to the vehicle body with cables or chains.**

It can be loaded and unloaded in two different ways:

- lifting the machine through a ramp;
- load by lifting the machine. It is necessary to fix the platform by means of chains and hooks at the represented lifting and fixing brackets.

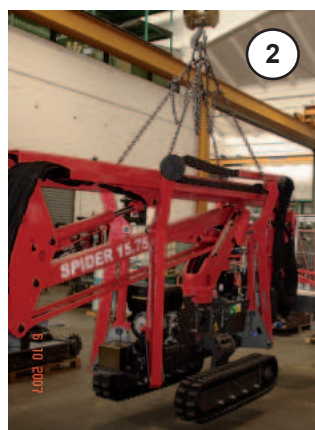

### ATTENTION

**Loading and un-loading the platform by means of ramps or on slopes: up to 5° deg it is allowed to operate the drive staying in the cage and opening maybe just a little the jib ( fig.3). When on ramps or slopes greater than 5 deg. it is necessary to dismantle the cage and to operate the platform from the ground staying at least 1 m far from the tracks ( fig.4).**

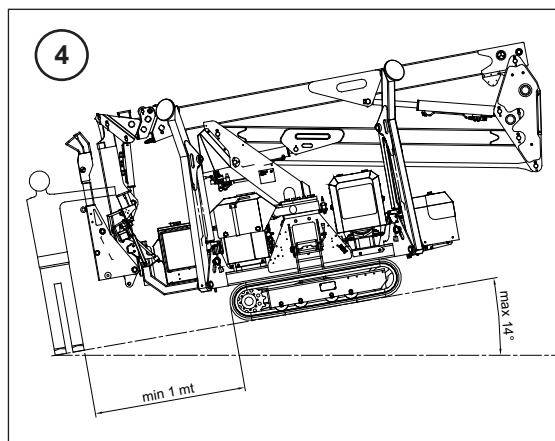
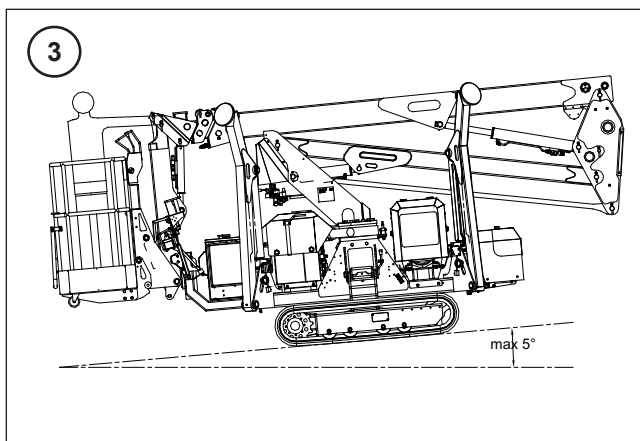

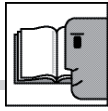

# B11

## TRANSPORT / TRASLATION

### MACHINE SECURING DURING TRANSPORTATION

During transportation the machine must ALWAYS be secured to the vehicle body with cables or chains. The hereunder photos show the hooking points at chassis(A), legs (B), main platform boom (C).



B

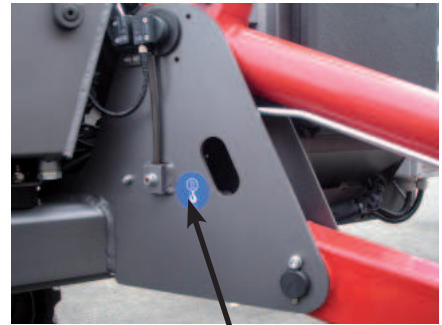

A



C



**DANGER**

*Always check that the ropes and chains used for are in good working condition.*



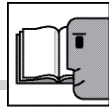

# B12

## START UP

The self propelled aerial work platform is powered by a diesel or Petrol engine and it can be equipped with electric power pack 220 Vac or 110 Vac in some Countries.

A main key selector SA1 is fitted to the main ground panel.

- Turn the **SA40** selector to pos. I to let the electric circuit being activated.

### FROM GROUND PANEL

- Turn and then release **SA40** from pos. I to pos. II enabling the cranking motor to run and switching the engine on.
- To switch the engine off, turn the selector key **SA40** to **O** or push down the red emergency button.
- Operating again this selector on pos. 2 when the engine is ON, it stops.

### FROM BASKET PANEL

- Push the green button SB58A to start the engine or the electric motor
- Release the **SAB58A** button once the engine starts.



### IMPORTANT

*When operating the booms the working position is joined, it's recommendable to switch off the engine or the electric motor to avoid overheating of the hydraulic circuit, reducing the pollution, saving energy and keeping the battery efficient (E electric version). An automatic pre-set timer will switch off the electric motor.*

### ELECTRIC POWER PACK OPERATING (OPTIONAL)

By plugging to **L1** the electric power from net and acting the **Q2** magnetothermic switches, the platform movements will be automatically operated by the electric power pack.

Following the above instructions the electric power pack will run instead of the main engine.

Same operations have to be followed to switch off the power pack.



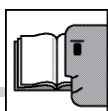

# B13

## GETTING STARTED



### BEWARE

*Before using the platform check all safety controls provided in section A04.*

### DRIVING

This model of self propelled platform allow the operator to drive by wide or narrow tracks gauge. To enlarge or reduce the gauge please ref. to sec. B03.

The driving is allowed with the platform in stowed position and the stowed machine lamp ON( H82 on cage panel – H83 on ground panel) only. It is possible to drive with the jib open ( uphill/downhill drive mode ) only if the H82-H83 lamps are ON.

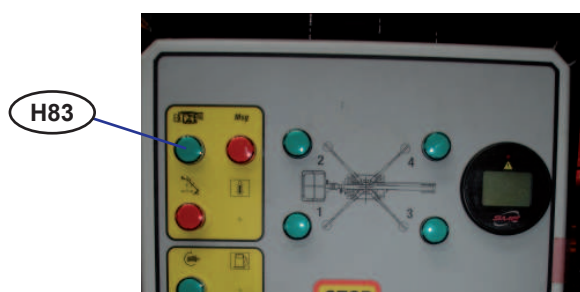

### BEWARE

*Damaging or tampering of the above mentioned device can affect the platform safety. Responsibility of the operator to keep it efficient!*

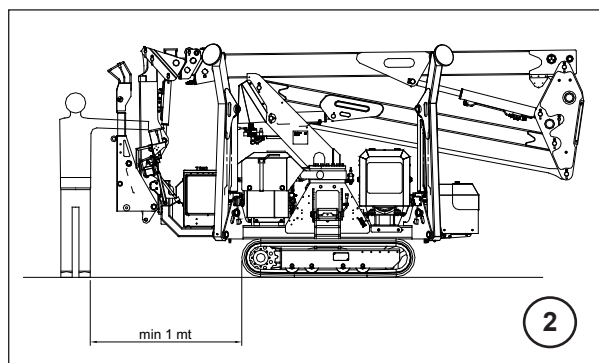
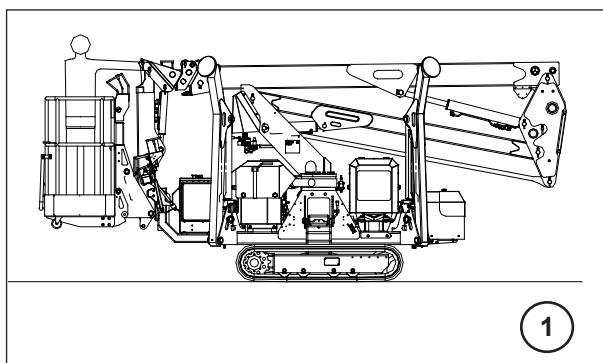

The tiltable drivig control station includes driving and stablizers control levers. It must be kept vertical when the platform is stowed ready for driving.

The driving has to be operated from the basket when fitted (fig.1) , or following the platform translating with dismantled basket staying at least 1 m far from the tracks (fig.2).

Take care about the stiffness of the under carriage and the centre of gravity of the platform booms. It must be driven carefully overcoming curb and holes.



### BEWARE

*Platform stability depends on tracks gauge. It is advisable to keep them extended while driving the machine on uneven and irregular ground.*

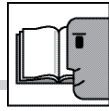

## GETTING STARTED

### MAKING THE STABILIZATION

Take care of locating the platform so that when legs are moved down do not catch any obstacle causing damage or tipping of the platform.

Take care of the visibility operating the legs down to the ground.

Ground must be compact and sufficiently hard to justify the pressure delivered by the platform.

Against soft ground, greater foot print plates must be adopted in between. They can be strong enough to distribute the force delivered by each platform's foot.



### BEWARE

*A sticker displaying the max ground force delivered by the leg is fitted on each foot.*



### ATTENTION

*Flying-jib shall always be fully stowed before starting the stabilization set-up. Stabilization procedure with flying jib on uphill drive mode will cause the boom movements being not allowed.*

By operating the ground control levers, stabilizing the platform paying attention to the level gauge fitted near the controls.

Platform must levelled horizontally watching the bubble inside of the level gauge, It must be centered into the circle.

The 4 green light lamps, monitoring the stabilizers down on ground, have to be ON. Only when they are ON, it will be possible to operate the platform booms.

When the platform is stabilized ready for aerial movements, it is necessary to lower the collapsible driving/stabilization control arm enabling the complete turret rotation of the aerial working platform.

When out from the stowed position, automatically shall no more be possible to lift up the legs. Only when booms are fully stowed again the legs shall be operate.



### DANGER

*Carelessness of the operator while stabilizing could cause a platform overturning. Evaluation about risks due to stabilization are essentials and peculiars.*

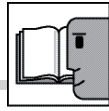

## GETTING STARTED

### HOW TO OPERATE THE AERIAL WORK PLATFORM

Max 2 people are allowed on board. The total max allowed weight is 200 kg.

Read carefully the SAFETY NORMES and the movements signs applied near to each control station.  
Read section B09.

Operate the extension boom out to release the platform from the stowing U brackets.

Raise the telescopic articulation moving the boom in the right working direction.

Raise the articulated cantilever boom implementing the obstacles overcoming and reducing the hanging of the rotating booms.

The platform is equipped with a device monitoring the overturning moment generated by the load in the cage and the side reach. The greater is the load into the basket the shorter the outreach will be. Throughout the mentioned device the safety of the platform is granted in any working position.

While operating the platform movements, approaching the max allowed outreach limit, the red lamp H103A will start flashing. Reaching the side reach limit, the red lamp H103A will be ON and booms movements will be arrested. To reset the platform movements is now necessary to hold the red button S7 pushed and at the mean time operate the telescopic booms in or by raising the articulating upper boom in order to reduce the side-reach of the platform.

Move the platform extension boom in for at least 80 cm. Doing the operation the red light will be off and all movements can be operated.

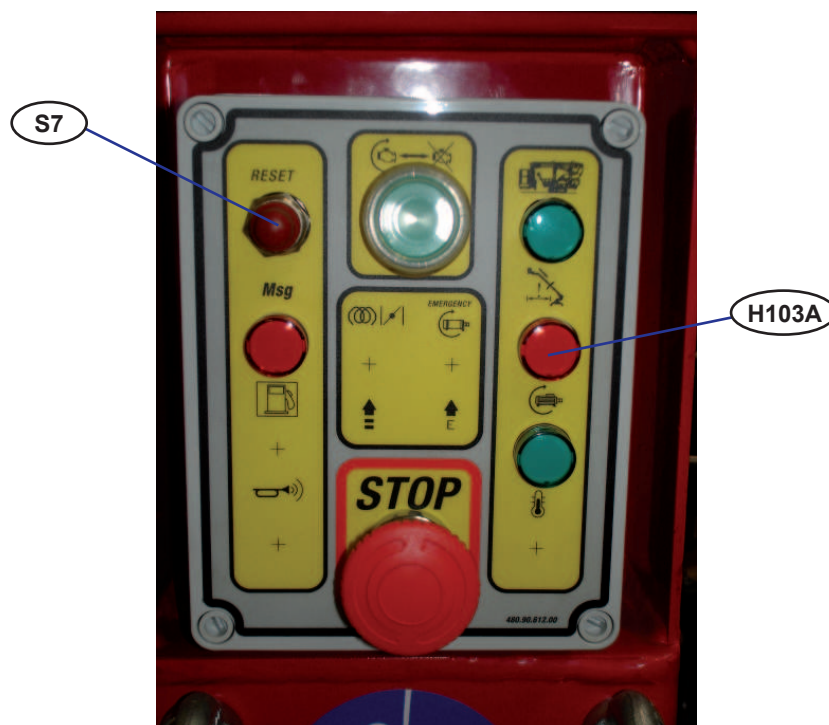

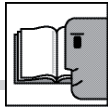

## GETTING STARTED

### BASKET LEVELLING COMPENSATOR

The aerial platform is equipped with an automatic closed self-levelling hydraulic circuit.

It can occur that the basket lose its own horizontality periodically, so it'll be necessary to compensate and make the allignment throughout the compensation movement.

Resetting of the basket can be done by means of its own movement positioned at the control valve fitted on the back of the platform column. (See Sec.B07)



### DANGER

***Basket leveling set-up shall be done by emergency ground controls (by using the yellow lever stored beside of them)with nobody on-board and with the basket near to the ground.***

Throughout the key-locked safety device, turn the selector valve on emergency control station.

Take the lever from its stowing position, link it to the valve block checking the yellow simbol positioned near to the valve block. Operate the movement to compensate the position of basket making it horizontally.

Once the levelling is correct, remove the lever from the control valve and store it in its position.

Move the selector valve back to basket controls and lock it. It's now possible to operate the aerial platform from basket controls.

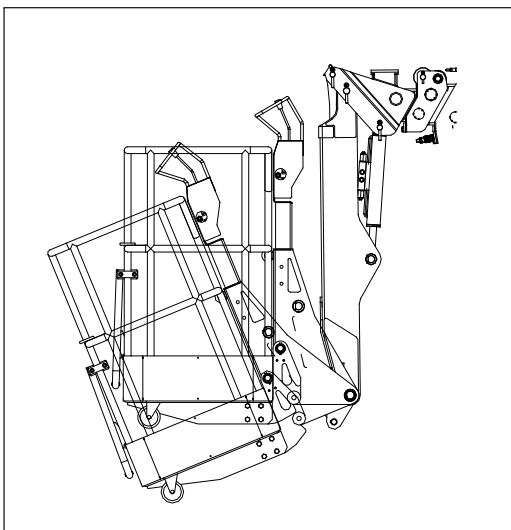

KEY PROTECTED SELECTOR



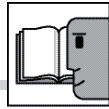

# B14

## EMERGENCY MANOEUVRES

### FAULTY BASKET CONTROLS

This kind of fault can only happen against burst of the high-pressure hydraulic hose connected to the inlet port of basket control valve.

- To move the basket to the ground, the platform must be operated by the emergency ground controls.
- Through the key safety locking device, turn the selector on emergency controls position.
- operate the platform from ground taking care of following the symbols applied near to control station.
- When the basket is down on the ground, get in touch to a SERVICE CENTRE to remove the platform from its location.

### EMERGENCY GROUND CONTROLS



SIMBOLS TO GROUND CONTROLS

LOCKED SELECTOR

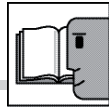

## EMERGENCY MANOEUVRES

### FAULTY ELECTRIC CIRCUIT

This kind of damage involve an emergency procedure to move down people into the basket, throughtout the hand pump. It necessary to enable the emergency ground control station as explained to the previous paragraph.

- Push & twist the herebelow represented dump valve once the sealing have been removed.

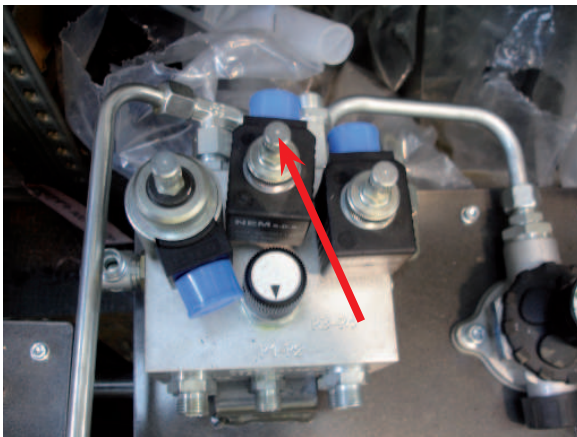

- Remove the hand pump lever from turret and fit it in its pump support.
- One person is necessary to pump while e second person will operate the emergency ground control station levers.
- ATTENTION should be paied to the selector located at the hydraulic manifold, see beside photo. It must be on position P1-P2 to operate the platfor movements.
- Once the platform has recovered, do not forget to release the push & swift button on the dump valve and move the platform to an Authorized service centre to do the riparation.

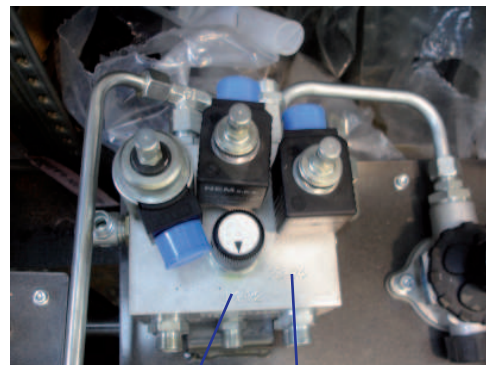

P1-P2  
PLATFORM + REAR LEGS

P3-P4  
FRONT LEGS

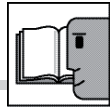

## EMERGENCY MANOEUVRES

### FAULTY ELECTRIC CIRCUIT

In case is necessary to lift up the stabilizers in order to close completely the machine, occur to execute the following instructions:

- Remove the plastic bonnet that covers the area D. Operate the solenoid valve by A cutting the seal and setting on the "push & twist" override device. Operate on the solenoid valve B by pushing and holding and keeping it pressed. Operate the solenoid valve C cutting the seal and setting on the "push & twist override device.

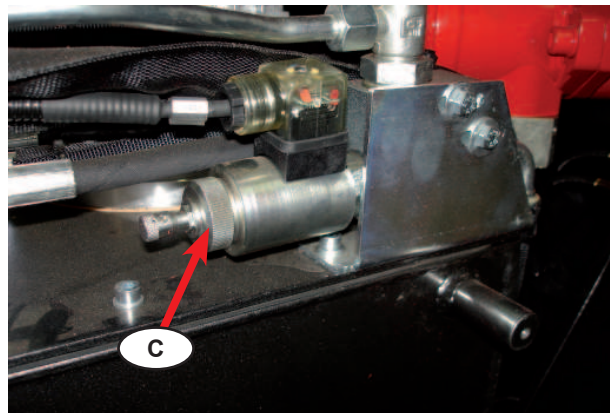
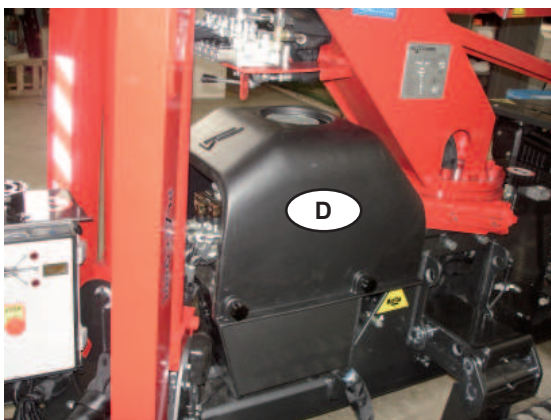
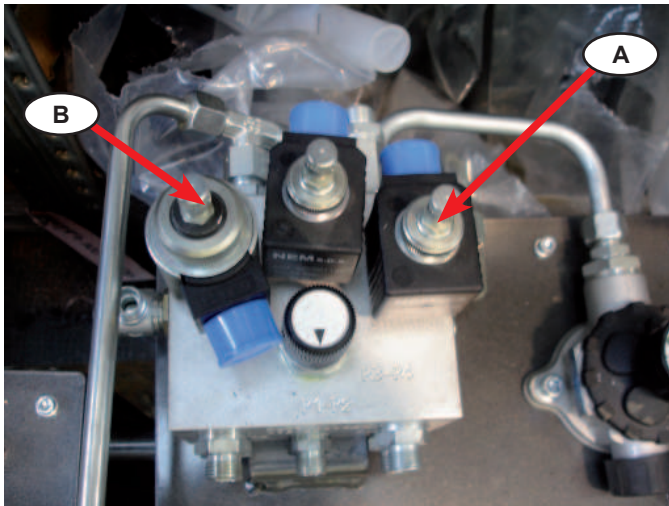



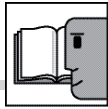

# B14

## EMERGENCY MANOEUVRES

### FAULTY ELECTRIC CIRCUIT

- Remove the hand pump lever from turret and fit it in its pump support.
- One person is necessary to pump “G” while a second person will operate the ground control station levers “F” for tracks and stabilizers.
- ATTENTION should be paid to the selector located at the hydraulic manifold “E”, **P1-P2** selection or **P3-P4** selection.
- Once the platform has recovered, do not forget to turn back the pin “A” again on the electrovalves and move the platform to an Authorized service centre to do the repair.

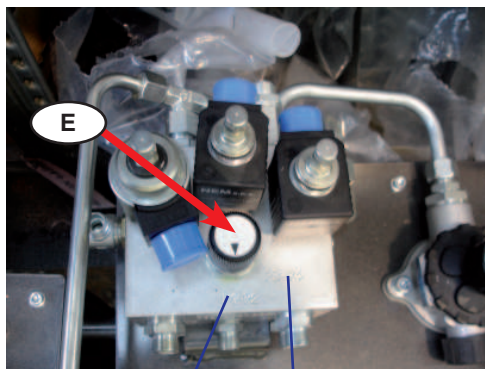

P1-P2  
REAR LEGS+RIGHT TRACK

P3-P4  
FRONT LEGS+LEFT TRACK

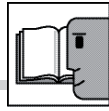

## EMERGENCY MANOEUVRES

If the electric plant does not work, you can start the motor manually as follows:

### KUBOTA ENGINE

The diesel Kubota engine cannot be started by hand.

### HONDA ENGINE

1. Disconnect the square electric connector fitted under the general box (pict.1).
2. Start the motor with the pull starter.
3. Use emergency controls bypassing valves as explained in the previous page for hand pump movements.
4. To turn the petrol motor off re-connect the disconnected connector.



### HATZ ENGINE

1. Remove the air filter cover.
2. Cutting the seal from fuel engine valve.
3. Rotate the pin how indicated in the pict.2
4. Start the motor with the pull starter.
5. Use emergency controls bypassing valves as explained in the previous page for hand pump movements.
6. Turn off the engine by rotating the pin how indicated in the picture.3

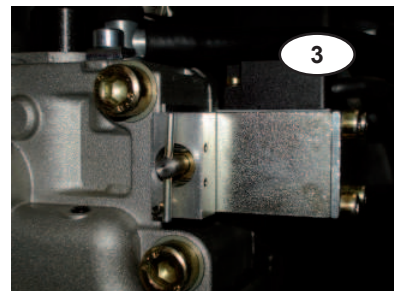
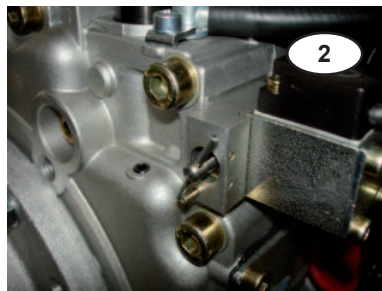
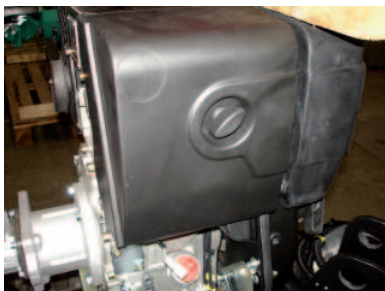

### ATTENTION

The machine has no safety measures.

---

## SECTION

# C



## MAINTENANCE



### **IMPORTANT**

*Replace worn parts with identical, original spare parts.*

*It is forbidden to make modifications or to replace parts with components that are not suitable and not authorized.*

*Before doing any maintenance work and especially maintenance and/or repairs to the electrical system or if it is necessary to do WELDING, COMPLETELY DISCONNECT ALL THE BATTERIES OF THE MACHINE BY REMOVING THE CONNECTOR TERMINALS.*

---



## C01

### INTRODUCTION

Routine maintenance includes those operations that have to be done periodically throughout the entire life of the machine and with scheduled frequency.

Inspection and careful maintenance allow the machine to work continually and with maximum efficiency. The following is a list of operations to be performed on the machine.

Remember also that the prompt replacement of a worn part avoids further damage and reduces the time that the machine is inoperative.

Other maintenance work not covered by this section is to be considered as special maintenance and is not part of the duty assigned to the operators who use the machine. This kind of work must be done by a specialized workshop.



#### **DANGER**

***All maintenance work must be done with the machine inoperative, in other words with the motor switched off, the electrical voltage to the panels cut off and the machine in the rest position.***

Spent lubricants and other liquids must be collected and disposed of according to the provisions of law since pouring them onto the ground causes pollution.



#### **WARNING**

***A few pages have been added to this manual so that the operator assigned to maintenance can keep notes of the maintenance work done and the number of hours the machine has worked, in the latter case making use of the hour-meter (P1).***



## C02

### MAINTENANCE WORK SAFETY

- Never do maintenance work while the batteries are being charged.
- Use tools and equipment that are suitable for the purpose.
- In the area/workshop used for the maintenance or during battery recharging only the qualified personnel assigned to maintenance should be present.
  
- Never leave metal tools such as spanners or the like on the machine as these could cause irreparable damage.
- Replace worn parts with identical, original Platform Basket spare parts.
- It is forbidden to make modifications or to replace parts with components that are not suitable and not authorized by Platform Basket.



## MAINTENANCE SCHEDULE

### FIRST 10 HOURS OF OPERATION

- Replacement of the oil filters cartridges on return line and high pressure whether fitted. (some models are equipped with return oil filter only.)
- Checking / tightening of screws, nuts and bolts
- Articulation pivot points and rotation slewing bearing greasing.
- Hydraulic oil level check

### EVERY 50 HOURS OF OPERATION

- Check that the emergency buttons work.
- Check the rotation gearbox oil level.
- Check the oil level in the track reduction gears.
- Grease the telescopic extensions.
- Hydraulic oil level check
- Check that the turret slewing limit switch works.
- Check/adjust the level and density of electrolyte liquid.
- Check the actual state of battery recharge.

### EVERY 250 HOURS OF OPERATION

- General check of the structure by a specialized workshop.
- Replacement of the oil filters cartridges on return line and high pressure whether fitted. (some models are equipped with return oil filter only.)
- Articulation pivot points and rotation slewing bearing greasing.
- Checking / tightening of screws, nuts and bolts

### EVERY 500 HOURS OF OPERATION

- Replace the hydraulic oil.
- Replace track reduction gear oil.



# C04

## GREASING LUBRICATION

The lubricators are indicated by RED caps. To refill them it is necessary to remove the cap and then pump grease in, until it comes out of the joints which should be moved a few times during this operation. Replace the red cap.

The smooth surfaces and the gears should first be cleaned of spent grease with a spatula and then lubricated with fresh grease using a brush.

Always remove excess grease.







### WARNING

*Damaged or clogged lubricators must always be replaced.*



### WARNING

*Use lubricant grease having the same characteristics as that shown in the specific table in this section.*

Description	Tool	Frequency
1. Stabiliser		100 hours
2. Turret rotation mechanism		250 hours
3. Joints and trunnions		250 hours
4. Telescopic elements		100 hours
5. Grease idler roller unit		50 hours

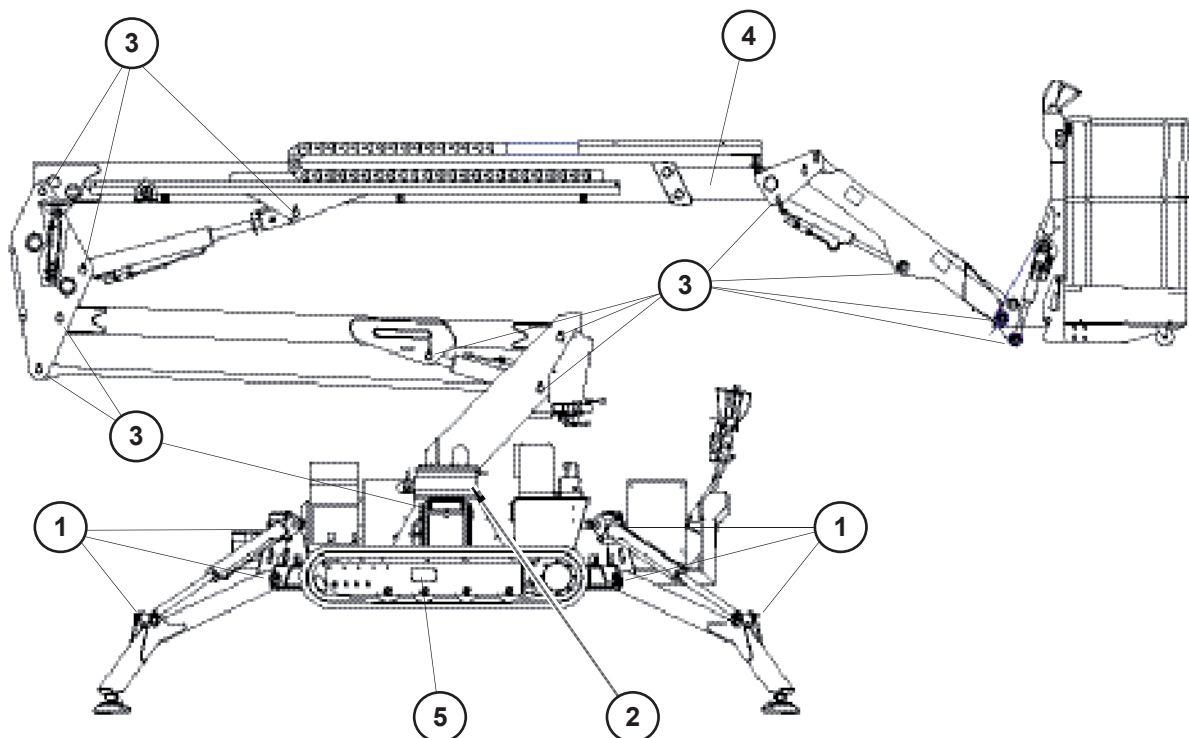



# C05



## LUBRICANT TABLE

**WARNING**

*All maintenance work must be done with the motor switched off and the machine in the rest position.*

**WARNING**

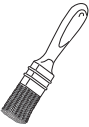
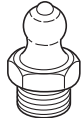
*Do not add oil different to what the manufacturer advises.*

	Grease 	Grease 	Hydraulic oil 	
<b>TOTAL</b>	MULTIS EP2	MULTIS EP2	AZOLLA ZS 46 ZS 68*	
<b>MOBIL</b>	MOBIL GREASE MP	MOBIL GREASE MP	DTE 25	
<b>ESSO</b>	BEACON EP2	BEACON EP2	NUTO H46 H68*	INVAROL EP46
<b>AGIP</b>	GR MU EP2	GR MU EP2	OSO 46 68*	ARNICA 46
<b>IP</b>	ATHESIA EP2	ATHESIA EP2	HYDRUS 46 68*	
<b>BP</b>	ENERGREASE LR MP	ENERGREASE LR MP	HENERGOL HL 80	
<b>PAKELO</b>	091 SILVER MPL GREASE	091 SILVER MPL GREASE	HYDRAULIC FLUID O HVI ISO46*	HYDRAULIC SINT HD ISO32
<b>SYNECO</b>	GREASE AS2	GREASE AS2	PRESS1400S/ISO VG46*	PRESS1400/ISO VG32

\* for hot climates



## SCREW TIGHTENING

All screws are to be tightened always with a torque wrench.

Excessive tightening of the screws may damage them while insufficient tightening defeats their purpose.

Each screw has its own specific value and the calibration of the torque wrench depends on its diameter and type.

If there are a number of screws for the same component (for example the slewing ring, plates, motor-gearboxes) it is necessary to tighten them two at a time in diametrically opposite positions.

Below is the table of values to be used.

### SCREW TIGHTENING TABLE

If the screws are lubricated then 60% of the torque value for tightening is to be used while if the screws are not lubricated then 70% of the value given in the table is to be used.

#### PRE-LOAD AND TORQUE FOR SCREWS WITH ISO THREAD AND WIDE PITCH

Nominal screw diameter	Max. pre-load V (kg.)				Max. torque Ma (kgm.)			
	6,6	8,8	10,9	12,9	6,6	8,8	10,9	12,9
	6 D	8 G	10 K	12 K	6 D	8 G	10 K	12 K
M 4x0,7	222	394	554	665	0,17	0,31	0,43	0,52
M 5x0,8	357	635	895	1070	0,33	0,60	0,84	1,01
M 6x1	507	902	1270	1520	0,58	1,03	1,46	1,75
M 7x1	728	1300	1820	2180	0,94	1,69	2,36	2,83
M 8x1,25	920	1640	2310	2770	1,39	2,48	3,49	4,19
M 9x1,25	1210	2160	3050	3630	2,05	3,67	5,18	6,17
M 10x1,5	1480	2600	3660	4380	2,83	4,97	7,00	8,37
M 12x1,75	2120	3780	5320	6380	4,74	8,46	11,90	14,30
M 14x2	2890	5160	7250	8700	7,54	13,46	18,92	22,70
M 16x2	3950	7020	9900	11900	11,50	20,40	28,80	34,60
M 18x2,5	4840	8600	12100	14500	16,00	28,40	40,00	48,00
M 20x2,5	6160	11000	15450	18500	22,20	39,60	55,60	66,60
M 22x2,5	7630	13600	19100	22900	30,00	53,00	74,50	90,00
M 24x3	8900	15900	22300	26700	39,00	70,00	98,00	117,00
M 27x3	11500	20600	28900	34700	56,00	101,00	142,00	170,00
M 30x3	14100	25200	35400	42400	77,00	138,00	193,00	232,00

The pre-load has been calculated as 70% of the minimum yield load.

The torque has been calculated using the formula (39) of the Junker & Blume manual, and giving a friction coefficient  $\mu$  ges the average value  $\mu$  ges = 0,14.





## SCREW TIGHTENING

### PRE-LOAD AND TORQUE FOR SCREWS WITH ISO THREAD AND SMALL PITCH

Nominal screw diameter	Max. pre-load V (kg.)				Max. torque Ma (kgm.)			
	6,6	8,8	10,9	12,9	6,6	8,8	10,9	12,9
	6 D	8 G	10 K	12 K	6 D	8 G	10 K	12 K
M 8x1	995	1750	2470	2960	1,48	2,60	3,70	4,40
M 10x1,25	1540	2740	3860	4630	2,90	5,20	7,30	8,70
M 12x1,25	2420	4140	5800	6980	5,30	9,10	12,80	15,40
M 12x1,5	2220	3960	5570	6680	5,00	8,90	12,50	15,00
M 14x1,5	3150	5600	7880	9450	8,00	14,30	20,00	24,00
M 16x1,5	4200	7500	10500	12600	12,00	21,50	30,00	36,00
M 18x1,5	5430	9700	13600	16300	17,40	31,00	43,00	52,00
M 20x1,5	6900	12100	17150	20600	24,40	43,00	61,00	73,00
M 22x1,5	8400	15000	21000	25200	32,00	57,50	80,50	97,00
M 24x2	9650	17200	24200	29000	41,00	73,50	103,00	124,00
M 27x2	12500	22300	31300	37500	60,00	107,00	150,00	180,00
M 30x2	15700	27800	39200	47000	83,00	147,00	208,00	250,00

The pre-load has been calculated as 70% of the minimum yield load.

The torque has been calculated using the formula (39) of the Junker & Blume manual, and giving a friction coefficient  $\mu$  ges the average value  $\mu$  ges = 0,14.

1. Slewing ring screws
2. Track reduction gear screws
3. Cage support screws

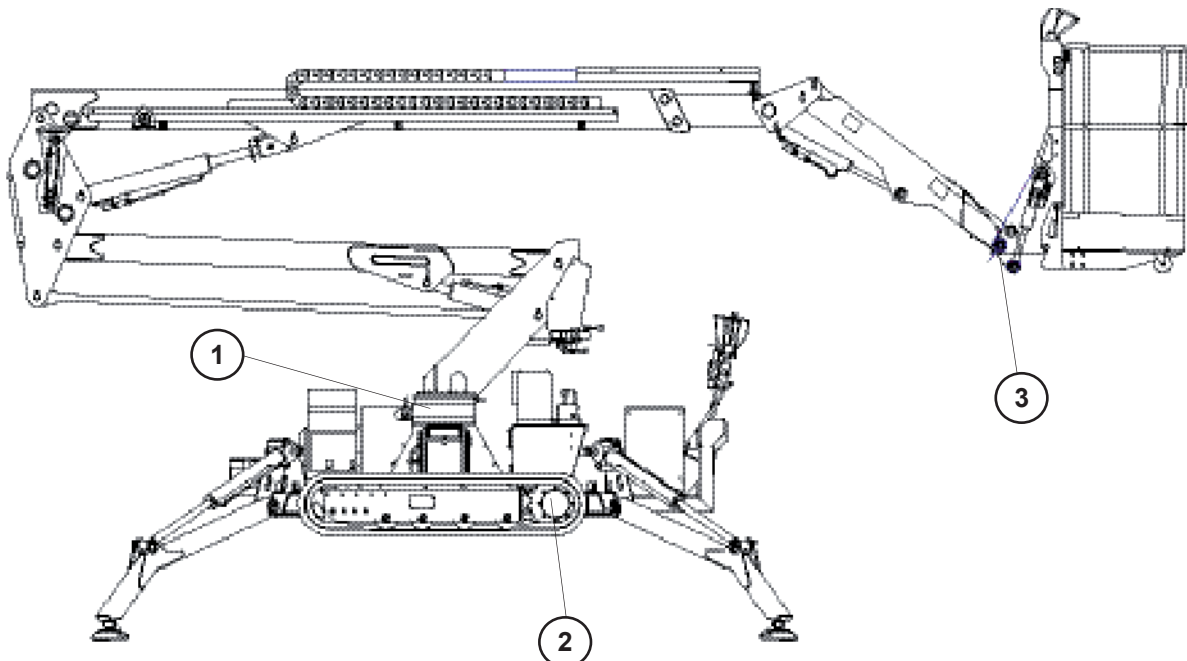



## C07

### SUPPLIES

#### DIESEL FUEL OR PETROL

Refill the tank with fuel depending on the motor type

#### GENERATOR MOTOR

See specific manual enclosed.

#### HYDRAULIC OIL

Refill the tank with hydraulic oil (see oil table).

#### BATTERIES

Check electrolyte level

#### DRIVE GEARBOX OIL

Refill with specific oil (see pages specified)

#### DRIVE GEARS

See specific pages.



## C08

### CHECK OIL LEVEL / TOP UP / REPLACE TRACK REDUCTION GEAR OIL

#### CHECK OIL LEVEL (WARNING! MODELS WITH THE DOUBLE SPEED DRIVE IT IS NOT NECESSARY TO CHECK THE OIL)

Turn the wheel so the two caps are aligned horizontally and remove one: the oil should come out slowly.

#### TOPPING UP OIL

Pour oil in through the removed cap until the right level is reached.

#### OIL REPLACEMENT

Turn the wheel until the two caps are aligned vertically and remove them both.

Wait for all the oil to come out.

Pour in the oil as explained in the paragraph "oil top up".

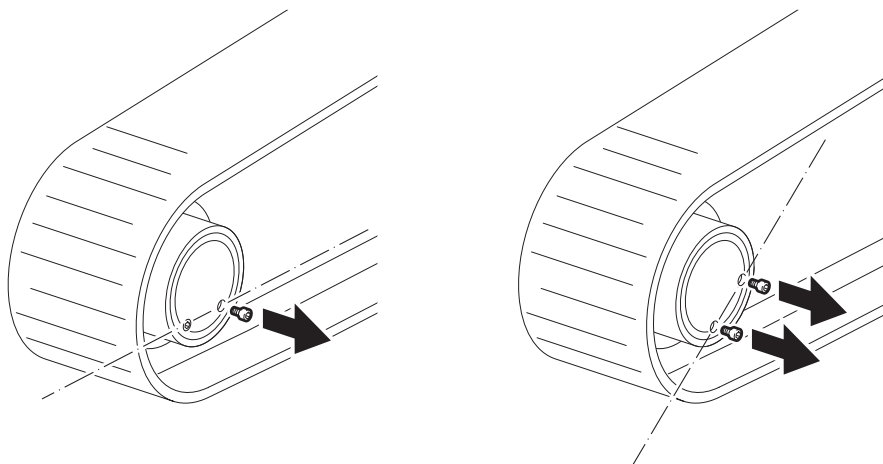



## C09

### HYDRAULIC OIL LEVEL CHECK

Check the right level directly on the tank.

Inspection shall be done when booms and legs are fully stowed and the oil level shall be visible from the sight level indicator (see A).





# C10

## SLIDING BLOCK WEAR AND CHAINS CONTROL

Check the wear of the sliding blocks in the extension elements. Replace them if, with the boom and extension elements completely retracted, there is a play exceeding 5 mm between them.



### **BEWARE**

*Replacement of the sliding blocks must be done at an authorized workshop.*



### **ATTENTION**

*Periodically check the tension of the telescopic elements extension chains.*

*Take the extension to the max spread*

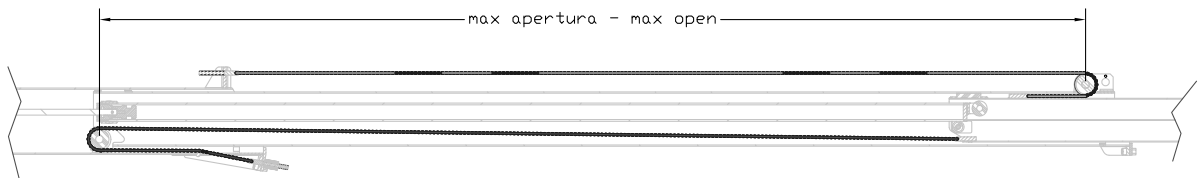

*Re-enter around 100 mm and check the chain arrow, that has not to exceed 10 mm*

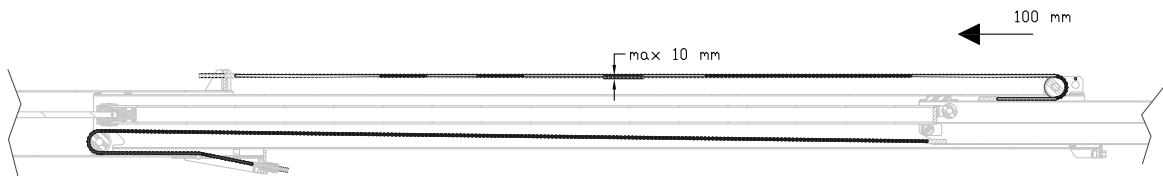

*Otherwise, contact an authorized service center*

---

**SECTION**

**D**

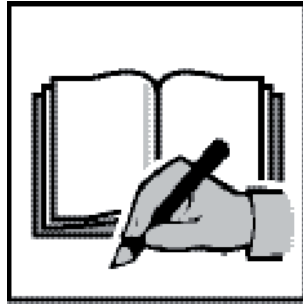

**REGISTER AND CONTROL COUPONS**



# D01

---

## MAINTENANCE RECORDS AND LOGBOOK

This inspection record is released by Platform Basket to the owner of the platform in accordance with EN280:2001+A2:2009.

The inspection record is to be considered as a part of the machine and must accompany it throughout its life until it is finally demolished

In the register it is necessary to record the following situations in regard to the life of the machine:

- transfers of ownership;
- replacement of motors, mechanisms, structural elements, electrical components, hydraulic components, safety devices and their related components;
- serious failures and their repairs;
- routine inspections.

---

### NOTE

***If there are insufficient pages in the register the necessary pages must be added by making photocopies and drawing them up like those already existing. On the additional pages the user must indicate the type of platform, the serial number and the year of construction so that they become an integral part of the register.***

---



## CHANGE OF OWNERSHIP RECORD

### SECTION A OWNERSHIP

#### DELIVERY OF THE PLATFORM TO THE FIRST OWNER

*Platform work type* \_\_\_\_\_

*serial number* \_\_\_\_\_

*year of construction* \_\_\_\_\_

*referred to in this logbook, was handed over by PlatformBasket on* \_\_\_\_\_

*to the company* \_\_\_\_\_

*with registered address at* \_\_\_\_\_

*According to the conditions agreed, with the technical characteristics, dimensions and functions specified in this instruction manual and in the summary contained in this Register.*

Platform Basket

\_\_\_\_\_



## CHANGE OF OWNERSHIP RECORD

### SECTION B SUCCESSIVE CHANGES OF OWNERSHIP

#### SUCCESSIVE CHANGES OF OWNERSHIP

Date \_\_\_\_\_

The ownership of the WORK PLATFORM \_\_\_\_\_ described in this manual is transferred to the Firm/Company:

\_\_\_\_\_  
\_\_\_\_\_  
\_\_\_\_\_  
\_\_\_\_\_

*It is hereby certified that, at the date mentioned above, the technical specifications, dimensions and functions of the WORK PLATFORM described in this manual conform to those originally existing and that any modifications have been recorded in this Register*

The Seller

The Buyer

\_\_\_\_\_

\_\_\_\_\_





## MAINTENANCE RECORD SPARE PART REPLACEMENT RECORD

### REPLACEMENT PART RECORD

REPLACEMENT OF: \_\_\_\_\_

Date \_\_\_\_\_

Manufacturer's number \_\_\_\_\_ Manufacturer \_\_\_\_\_

Specifications \_\_\_\_\_

REPLACED BY: \_\_\_\_\_

Manufacturer's number \_\_\_\_\_ Manufacturer \_\_\_\_\_

Specifications \_\_\_\_\_

Reason for the replacement \_\_\_\_\_

The representative of the company responsible for the replacement \_\_\_\_\_

The user \_\_\_\_\_



## MAINTENANCE RECORD SPARE PART REPLACEMENT RECORD

### REPLACEMENT PART RECORD

REPLACEMENT OF: \_\_\_\_\_

Date \_\_\_\_\_

Manufacturer's number \_\_\_\_\_ Manufacturer \_\_\_\_\_

Specifications \_\_\_\_\_

REPLACED BY: \_\_\_\_\_

Manufacturer's number \_\_\_\_\_ Manufacturer \_\_\_\_\_

Specifications \_\_\_\_\_

Reason for the replacement \_\_\_\_\_

The representative of the company responsible for the replacement \_\_\_\_\_

The user \_\_\_\_\_



## MAINTENANCE RECORD SPARE PART REPLACEMENT RECORD

### REPLACEMENT PART RECORD

REPLACEMENT OF: \_\_\_\_\_

Date \_\_\_\_\_

Manufacturer's number \_\_\_\_\_ Manufacturer \_\_\_\_\_

Specifications \_\_\_\_\_

REPLACED BY: \_\_\_\_\_

Manufacturer's number \_\_\_\_\_ Manufacturer \_\_\_\_\_

Specifications \_\_\_\_\_

Reason for the replacement \_\_\_\_\_

The representative of the company responsible for the replacement \_\_\_\_\_

The user \_\_\_\_\_



## MAINTENANCE RECORD SPARE PART REPLACEMENT RECORD

### REPLACEMENT PART RECORD

REPLACEMENT OF: \_\_\_\_\_

Date \_\_\_\_\_

Manufacturer's number \_\_\_\_\_ Manufacturer \_\_\_\_\_

Specifications \_\_\_\_\_

REPLACED BY: \_\_\_\_\_

Manufacturer's number \_\_\_\_\_ Manufacturer \_\_\_\_\_

Specifications \_\_\_\_\_

Reason for the replacement \_\_\_\_\_

The representative of the company responsible for the replacement \_\_\_\_\_

The user \_\_\_\_\_



## MAINTENANCE RECORD SPARE PART REPLACEMENT RECORD

### MECHANISM REPLACEMENT RECORD

Date \_\_\_\_\_ Description of the element \_\_\_\_\_

Manufacturer \_\_\_\_\_ Supplied by \_\_\_\_\_

Reason for the replacement \_\_\_\_\_

The representative of the company responsible for the replacement \_\_\_\_\_

The user \_\_\_\_\_

### MECHANISM REPLACEMENT RECORD

Date \_\_\_\_\_ Description of the element \_\_\_\_\_

Manufacturer \_\_\_\_\_ Supplied by \_\_\_\_\_

Reason for the replacement \_\_\_\_\_

The representative of the company responsible for the replacement \_\_\_\_\_

The user \_\_\_\_\_



# D03

## MAINTENANCE RECORD SPARE PART REPLACEMENT RECORD

### MECHANISM REPLACEMENT RECORD

Date \_\_\_\_\_ Description of the element \_\_\_\_\_

Manufacturer \_\_\_\_\_ Supplied by \_\_\_\_\_

Reason for the replacement \_\_\_\_\_

The representative of the company responsible for the replacement \_\_\_\_\_

The user \_\_\_\_\_

### MECHANISM REPLACEMENT RECORD

Date \_\_\_\_\_ Description of the element \_\_\_\_\_

Manufacturer \_\_\_\_\_ Supplied by \_\_\_\_\_

Reason for the replacement \_\_\_\_\_

The representative of the company responsible for the replacement \_\_\_\_\_

The user \_\_\_\_\_



## MAINTENANCE RECORD SPARE PART REPLACEMENT RECORD

### STRUCTURAL PART REPLACEMENT RECORD

Date \_\_\_\_\_ Description of the element \_\_\_\_\_

Manufacturer \_\_\_\_\_ Supplied by \_\_\_\_\_

Reason for the replacement \_\_\_\_\_

The representative of the company responsible for the replacement \_\_\_\_\_

The user \_\_\_\_\_

### STRUCTURAL PART REPLACEMENT RECORD

Date \_\_\_\_\_ Description of the element \_\_\_\_\_

Manufacturer \_\_\_\_\_ Supplied by \_\_\_\_\_

Reason for the replacement \_\_\_\_\_

The representative of the company responsible for the replacement \_\_\_\_\_

The user \_\_\_\_\_



**D03**

**MAINTENANCE RECORD  
SPARE PART REPLACEMENT RECORD**

**STRUCTURAL PART REPLACEMENT RECORD**

*Date* \_\_\_\_\_ *Description of the element* \_\_\_\_\_

*Manufacturer* \_\_\_\_\_ *Supplied by* \_\_\_\_\_

*Reason for the replacement* \_\_\_\_\_

*The representative of the company responsible for the replacement* \_\_\_\_\_

*The user* \_\_\_\_\_

**STRUCTURAL PART REPLACEMENT RECORD**

*Date* \_\_\_\_\_ *Description of the element* \_\_\_\_\_

*Manufacturer* \_\_\_\_\_ *Supplied by* \_\_\_\_\_

*Reason for the replacement* \_\_\_\_\_

*The representative of the company responsible for the replacement* \_\_\_\_\_

*The user* \_\_\_\_\_





## MAINTENANCE RECORD SPARE PART REPLACEMENT RECORD

### HYDRAULIC COMPONENTS REPLACEMENT RECORD

Date \_\_\_\_\_ Description of the element \_\_\_\_\_

Manufacturer \_\_\_\_\_ Supplied by \_\_\_\_\_

Reason for the replacement \_\_\_\_\_

The representative of the company responsible for the replacement \_\_\_\_\_

The user \_\_\_\_\_

### HYDRAULIC COMPONENTS REPLACEMENT RECORD

Date \_\_\_\_\_ Description of the element \_\_\_\_\_

Manufacturer \_\_\_\_\_ Supplied by \_\_\_\_\_

Reason for the replacement \_\_\_\_\_

The representative of the company responsible for the replacement \_\_\_\_\_

The user \_\_\_\_\_



## MAINTENANCE RECORD SPARE PART REPLACEMENT RECORD

### HYDRAULIC COMPONENTS REPLACEMENT RECORD

Date \_\_\_\_\_ Description of the element \_\_\_\_\_

Manufacturer \_\_\_\_\_ Supplied by \_\_\_\_\_

Reason for the replacement \_\_\_\_\_

The representative of the company responsible for the replacement \_\_\_\_\_

The user \_\_\_\_\_

### HYDRAULIC COMPONENTS REPLACEMENT RECORD

Date \_\_\_\_\_ Description of the element \_\_\_\_\_

Manufacturer \_\_\_\_\_ Supplied by \_\_\_\_\_

Reason for the replacement \_\_\_\_\_

The representative of the company responsible for the replacement \_\_\_\_\_

The user \_\_\_\_\_



## MAINTENANCE RECORD SPARE PART REPLACEMENT RECORD

### ELECTRICAL COMPONENT REPLACEMENT RECORD

Date \_\_\_\_\_ Description of the element \_\_\_\_\_

Manufacturer \_\_\_\_\_ Supplied by \_\_\_\_\_

Reason for the replacement \_\_\_\_\_

The representative of the company responsible for the replacement \_\_\_\_\_

The user \_\_\_\_\_

### ELECTRICAL COMPONENT REPLACEMENT RECORD

Date \_\_\_\_\_ Description of the element \_\_\_\_\_

Manufacturer \_\_\_\_\_ Supplied by \_\_\_\_\_

Reason for the replacement \_\_\_\_\_

The representative of the company responsible for the replacement \_\_\_\_\_

The user \_\_\_\_\_



## MAINTENANCE RECORD SPARE PART REPLACEMENT RECORD

### ELECTRICAL COMPONENT REPLACEMENT RECORD

Date \_\_\_\_\_ Description of the element \_\_\_\_\_

Manufacturer \_\_\_\_\_ Supplied by \_\_\_\_\_

Reason for the replacement \_\_\_\_\_

The representative of the company responsible for the replacement \_\_\_\_\_

The user \_\_\_\_\_

### ELECTRICAL COMPONENT REPLACEMENT RECORD

Date \_\_\_\_\_ Description of the element \_\_\_\_\_

Manufacturer \_\_\_\_\_ Supplied by \_\_\_\_\_

Reason for the replacement \_\_\_\_\_

The representative of the company responsible for the replacement \_\_\_\_\_

The user \_\_\_\_\_



## MAINTENANCE RECORD SPARE PART REPLACEMENT RECORD

SAFETY EQUIPMENT REPLACEMENT CARD	
Date _____	Description of the element _____
Manufacturer _____	Supplied by _____
Reason for the replacement _____	
The representative of the company responsible for the replacement _____	
The user _____	

SAFETY EQUIPMENT REPLACEMENT CARD	
Date _____	Description of the element _____
Manufacturer _____	Supplied by _____
Reason for the replacement _____	
The representative of the company responsible for the replacement _____	
The user _____	



## MAINTENANCE RECORD SPARE PART REPLACEMENT RECORD

SAFETY EQUIPMENT REPLACEMENT CARD	
Date _____	Description of the element _____
Manufacturer _____	Supplied by _____
Reason for the replacement _____	
The representative of the company responsible for the replacement _____	
The user _____	

SAFETY EQUIPMENT REPLACEMENT CARD	
Date _____	Description of the element _____
Manufacturer _____	Supplied by _____
Reason for the replacement _____	
The representative of the company responsible for the replacement _____	
The user _____	



## MAINTENANCE RECORD SPARE PART REPLACEMENT RECORD

### SERIOUS FAILURES

*Date* \_\_\_\_\_ *Description of the element* \_\_\_\_\_

*Manufacturer* \_\_\_\_\_ *Supplied by* \_\_\_\_\_

*Reason for the replacement* \_\_\_\_\_

*The representative of the company responsible for the replacement* \_\_\_\_\_

*The user* \_\_\_\_\_

### SERIOUS FAILURES

*Date* \_\_\_\_\_ *Description of the element* \_\_\_\_\_

*Manufacturer* \_\_\_\_\_ *Supplied by* \_\_\_\_\_

*Reason for the replacement* \_\_\_\_\_

*The representative of the company responsible for the replacement* \_\_\_\_\_

*The user* \_\_\_\_\_



## MAINTENANCE RECORD SPARE PART REPLACEMENT RECORD

### SERIOUS FAILURES

Date \_\_\_\_\_ Description of the element \_\_\_\_\_

Manufacturer \_\_\_\_\_ Supplied by \_\_\_\_\_

Reason for the replacement \_\_\_\_\_

The representative of the company responsible for the replacement \_\_\_\_\_

The user \_\_\_\_\_

### SERIOUS FAILURES

Date \_\_\_\_\_ Description of the element \_\_\_\_\_

Manufacturer \_\_\_\_\_ Supplied by \_\_\_\_\_

Reason for the replacement \_\_\_\_\_

The representative of the company responsible for the replacement \_\_\_\_\_

The user \_\_\_\_\_









---

**SECTION**

**EA**

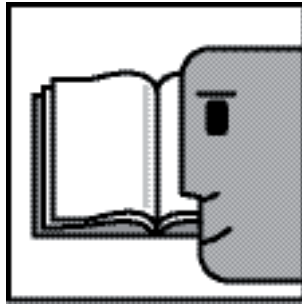

**INTEGRATION FOR RADIO COMMAND VERSION**

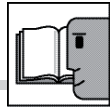

## SIGNS AFFIXED TO THE MACHINE

Cage controls



Ground controls (Emergency)

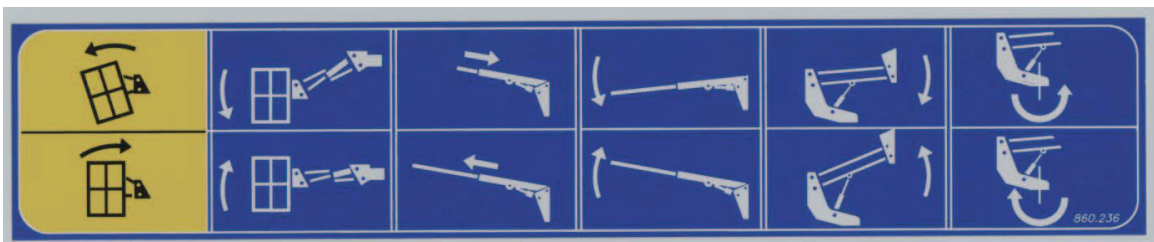

Ground control (Traslation and stabilization).

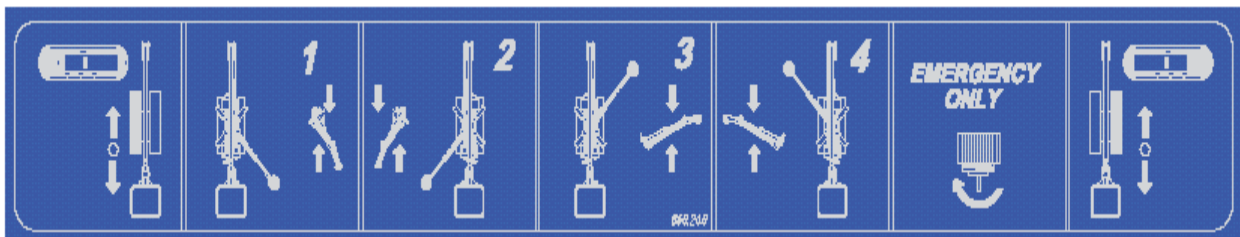

Danger hot surface.



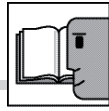

## GENERAL DESCRIPTION



### WARNING

The model illustrated may be slightly different from the model in possession.

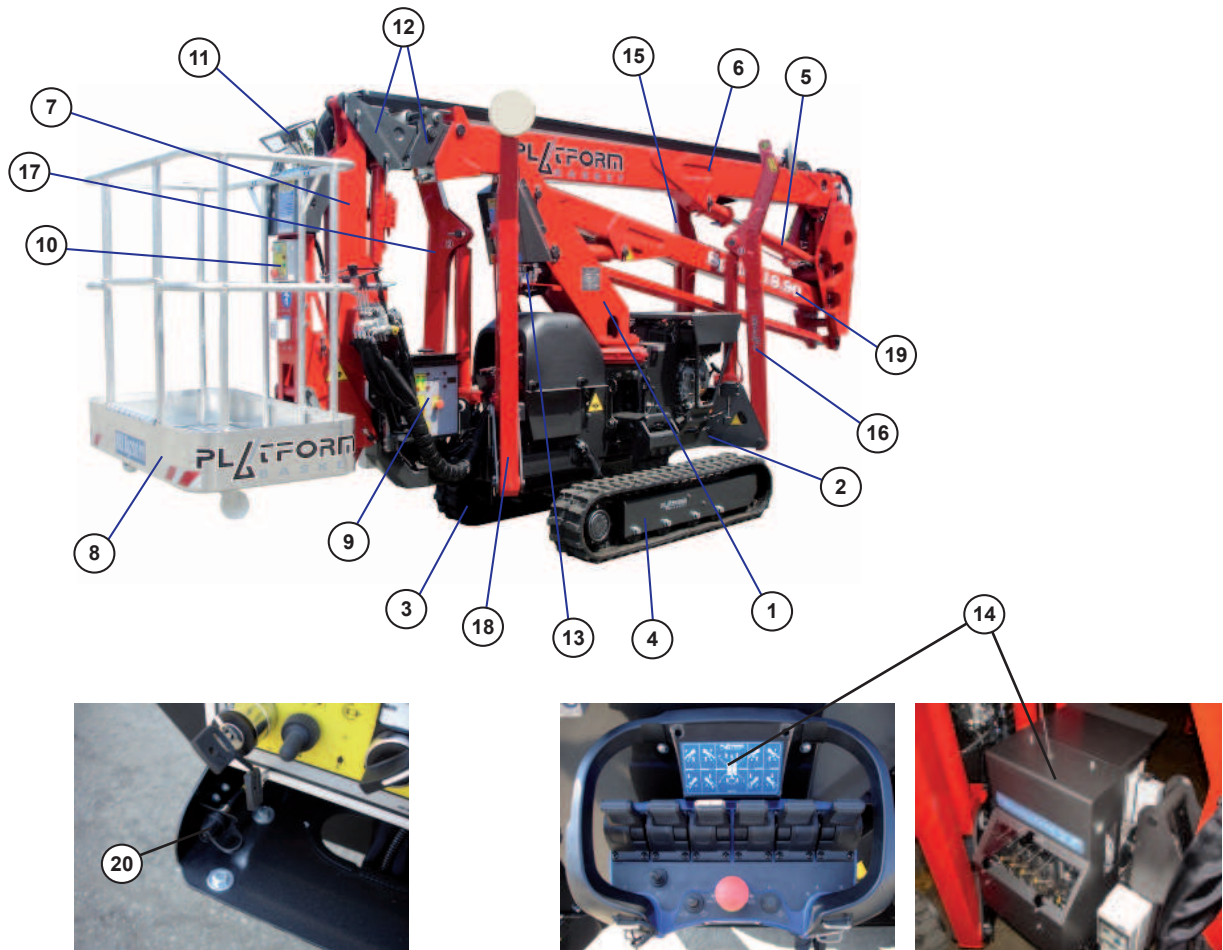

1. Turret
2. Truck
3. Left track (\*)
4. Right track (\*)
5. Telescopic boom lifting cylinder
6. Telescopic boom
7. Jib
8. Basket
9. Ground control panel
10. Basket control panel
11. Control levers in the basket
12. Telescopic element
13. Ground control levers (for the aerial parts)
14. Radio remote ground control levers (for travelling/stabilisation)
15. Front left stabiliser (4)
16. Front right stabiliser (3)
17. Rear left stabiliser (2)
18. Rear right stabiliser (1)
19. Scissor booms
20. Connector for remote control cable

(\*) The normal driving direction for the self-propelled platform is determined by the basket (8) at the rear.

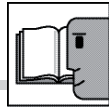

## CONTROLS FOR TRAVELLING / STABILISATION

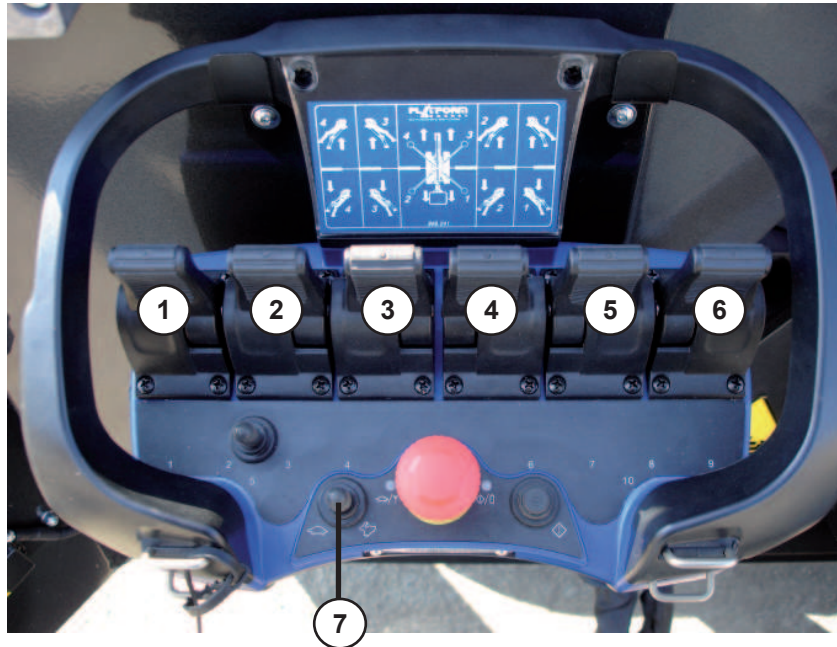

### NOTE

*These controls are enabled ONLY with the aerial part stowed.*

**1 Stabiliser N°4 movement**

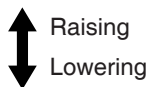

**2 Stabiliser N°3 movement**

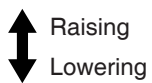

**3 Left track running**

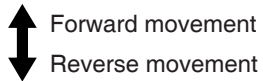

**4 Right track running**

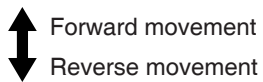

**5 Stabiliser N°2 movement**

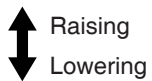

**6 Stabiliser N°1 movement**

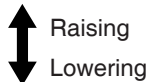

**7 Rabbit / turtle selector (only with double speed hydraulic motor)**

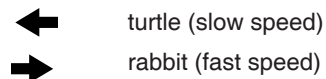

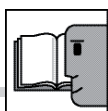

## EA03

### CONTROLS FOR TRAVELLING/ STABILISATION



#### IMPORTANT!

*Is strictly recommended to operate travelling and stabilizing staying at the right distance from the machine, the machine tip over can cause serious damages to the operator.*



Proceed as following instructions in order to enable the operations:

- Switch ON the electric insatallation with the key selector present on the electric ground panel.
- Press button **D** present on the command console:
- The remote control box i.e.d. E shall be ON and the receiver unit box display G shall report the message IH when in radio mode and I- when in cable-remote control mode.





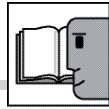

## CONTROLS FOR TRAVELLING/ STABILISATION

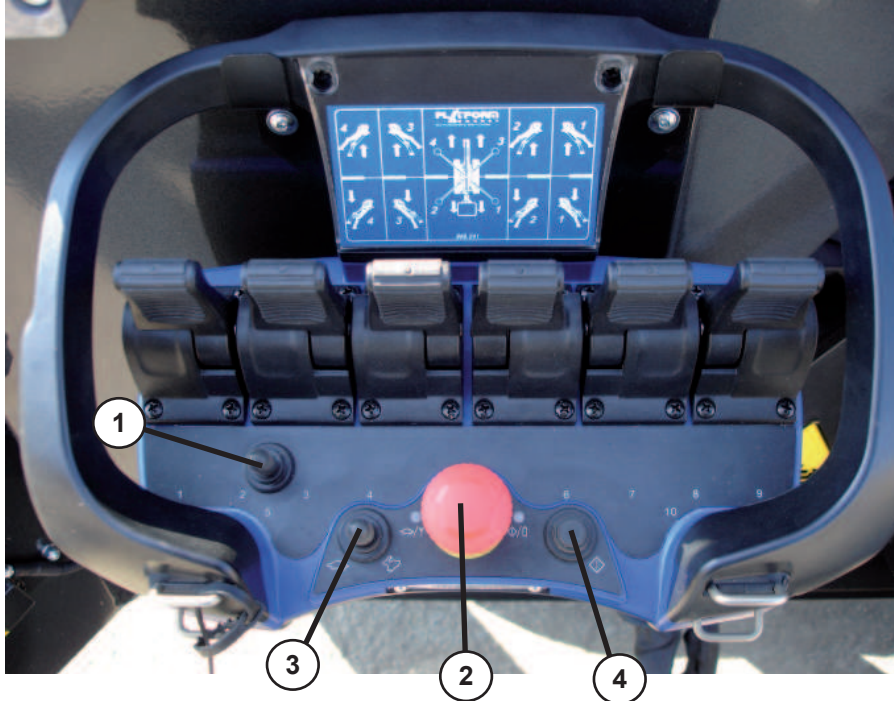

**1 Engine Start / Stop**

- ← Start of the endothermic/electric motor
- Stop of the endothermic/electric motor

**2 Emergency push button**

If pressed it switches OFF the transmitting console and disables all the functions present on it.

**3 Rabbit / turtle selector (speed selection with double speed motor, if present)**

- ← turtle (slow speed)
- rabbit (high speed)

**3 Rabbit / turtle selector + button n°4 (automatic stabilization/destabilization selection, if present)**

- + button n°4 automatic stabilization
- ← + button n°4 automatic destabilization

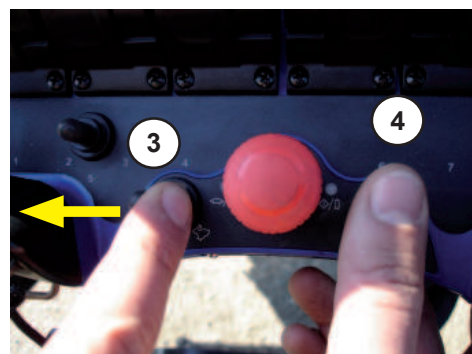

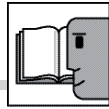

## CONTROLS FOR TRAVELLING/ STABILISATION

### Battery change

Extract the battery **A** from the bottom side of the transmitter, open the lid **B** and take out the spare battery, fit the empty battery instead of the full charge battery and connect the full charged one in the transmitter.

The battery is automatically charged by means of the battery charger **C** even if the electric installation is switched OFF, once the charge is finished the battery charger switch OFF by itself.

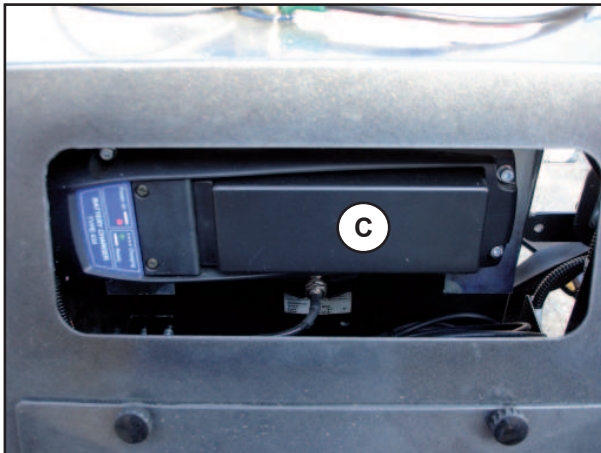
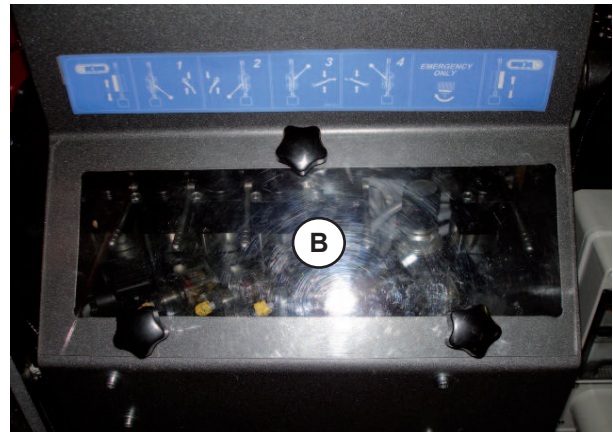
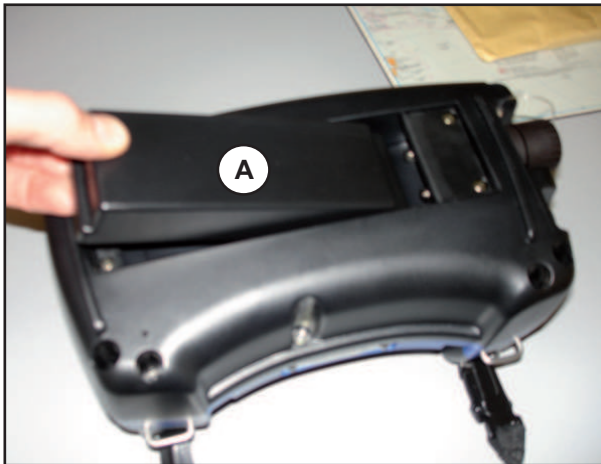

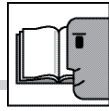

## EMERGENCY MANOEUVRE

### FAULTY ELECTRIC CIRCUIT

This kind of damage involve an emergency procedure to move down people into the basket, throughtout the hand pump. It necessary to enable the emergency ground control station as explained to the previous paragraph.

- Push & twist the herebelow represented dump valve once the sealing have been removed.
- Remove the hand pump lever from turret and fit it in its pump support.
- One person is necessary to pump while e second person will operate the emergency ground control station levers.
- Once the platform has recovered, do not forget to release the push & swift button on the dump valve and move the platform to an Authorized service centre to do the riparation.

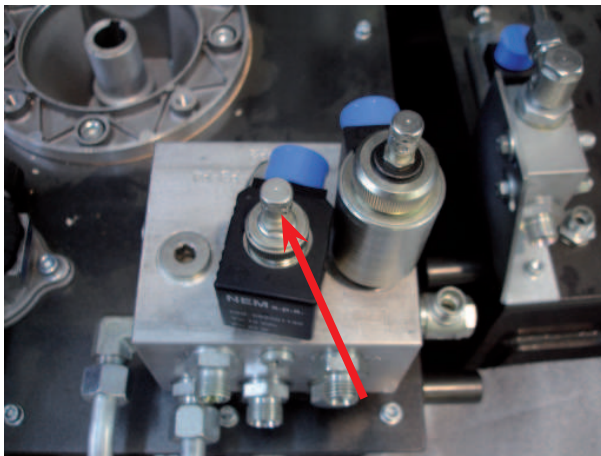

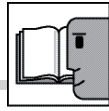

## EMERGENCY MANOEUVRE

### FAULTY ELECTRIC CIRCUIT

In case is necessary to lift up the stabilizers in order to close completely the machine, occur to execute the following instructions:

- Remove the plastic carter over the area **D**. Push with a screwdriver the pin on the valve **A**. Keep pressed the pin during the emergency manoeuvre.
- Screw the handle **C** too.
- Now is enabled the hydraulic line to the stabilizers.

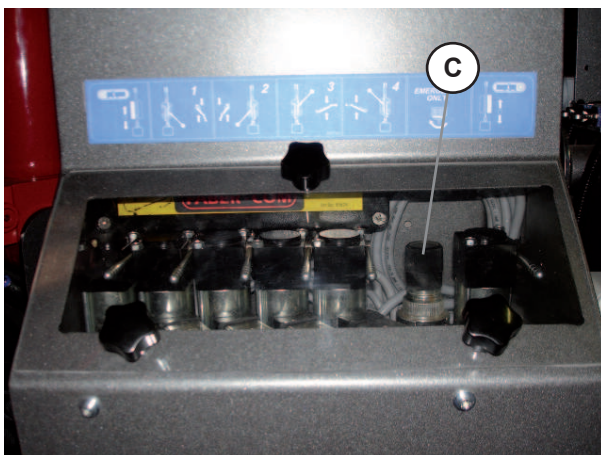
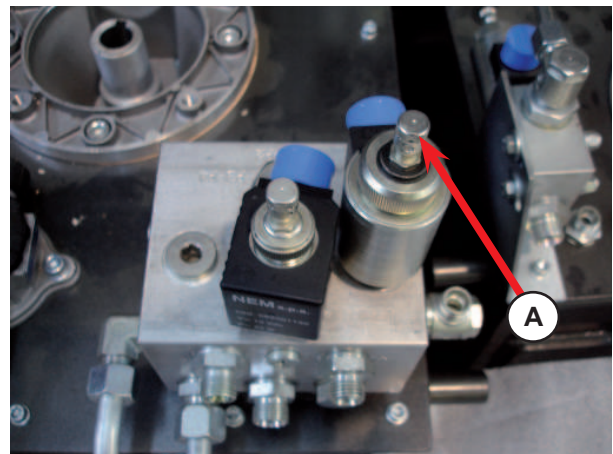
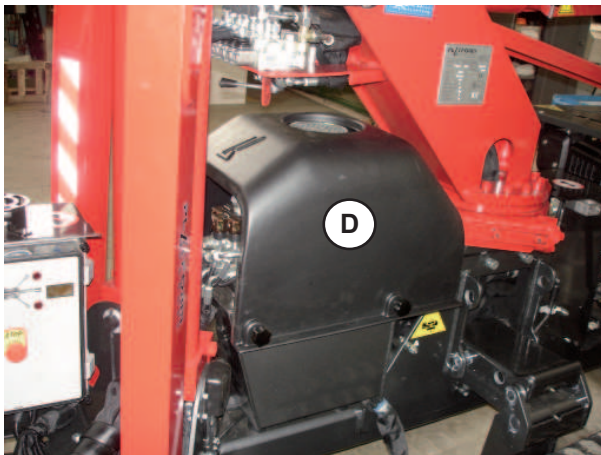

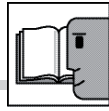

## EMERGENCY MANOEUVRE

### FAULTY ELECTRIC CIRCUIT

- Remove the hand pump lever from turret and fit it in its pump support.
- One person is necessary to pump **G** while e second person will operate the ground control station levers **F** for tracks and stabilizers.
- ATTENTION should be paid to the levers orientation of each stabilizer: lifting the lever the stabilizer goes down, lowering the lever the stabilizer goes up.
- Once the platform has recovered, do not forget to turn back **C** again on the electrovalves and move the platform to an Authorized service centre to do the riparation.
- Tracks operation is not allowed.

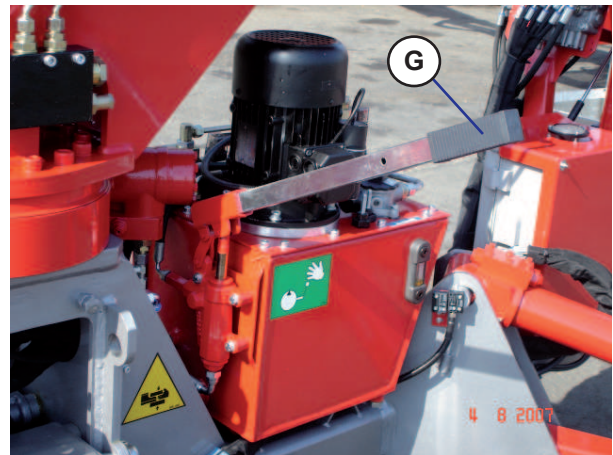
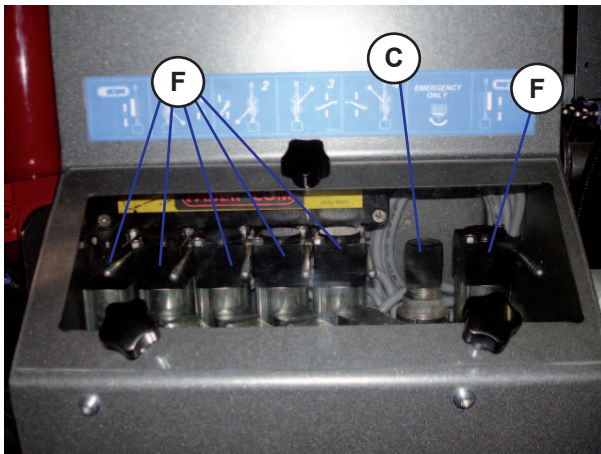

---

**SECTION**

**EB**

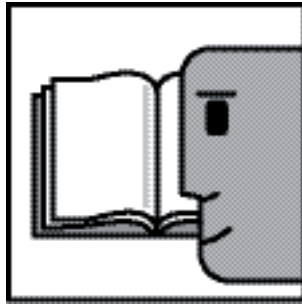

**INTEGRATION FOR CABLE COMMAND VERSION**

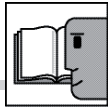

## SIGNS AFFIXED TO THE MACHINE

Cage controls

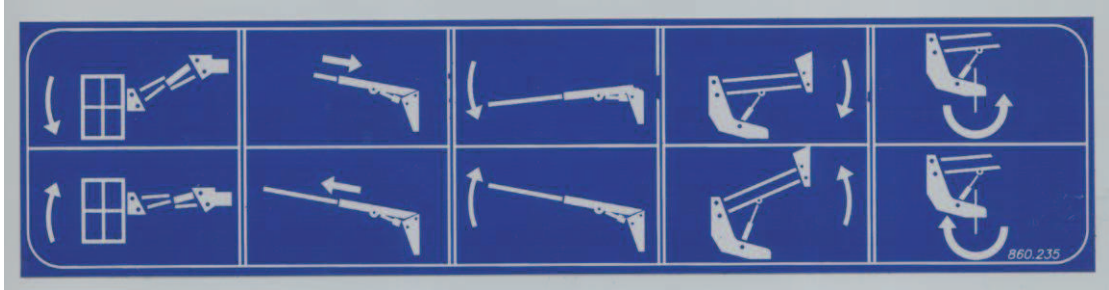

Ground controls (Emergency)

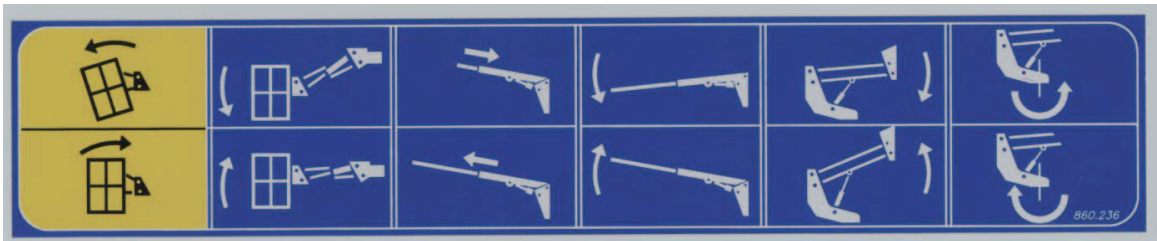

Ground control (stabilization).

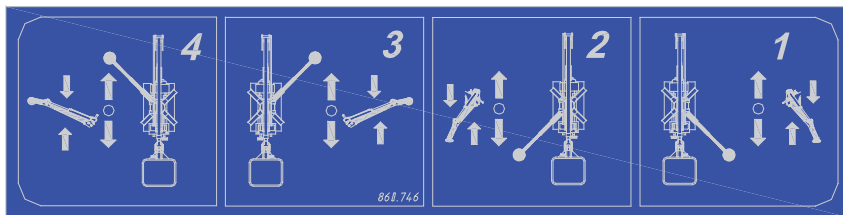

Ground control (Traslation).

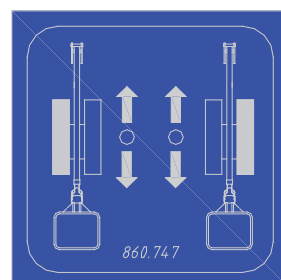
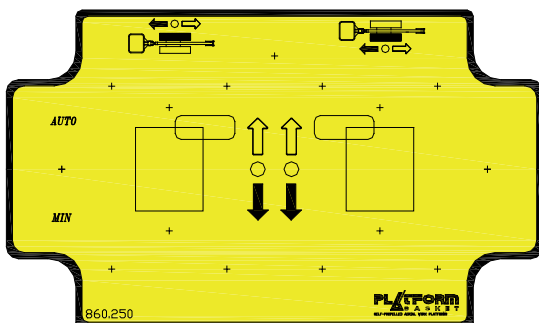

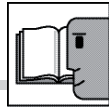

## GENERAL DESCRIPTION



### WARNING

The model illustrated may be slightly different from the model in possession.

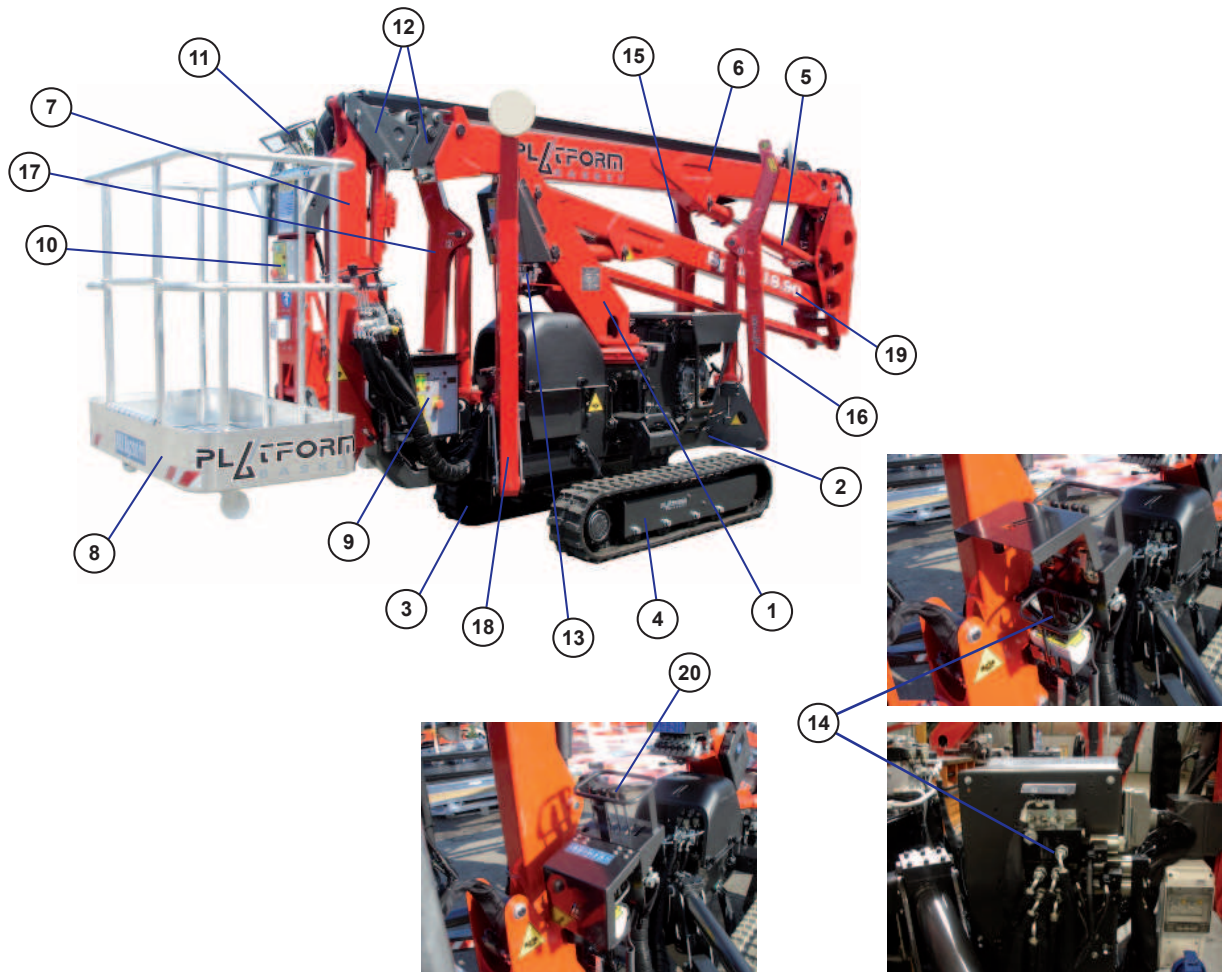

1. Turret
2. Truck
3. Left track (\*)
4. Right track (\*)
5. Telescopic boom lifting cylinder
6. Telescopic boom
7. Jib
8. Basket
9. Ground control panel
10. Basket control panel
11. Control levers in the basket
12. Telescopic element
13. Ground control levers (for the aerial parts)
14. Cable remote ground control levers (for travelling)
15. Front left stabiliser (4)
16. Front right stabiliser (3)
17. Rear left stabiliser (2)
18. Rear right stabiliser (1)
19. Scissor booms
20. Cable remote ground control levers (for stabilisation)

(\*) The normal driving direction for the self-propelled platform is determined by the basket (8) at the rear.



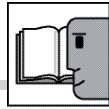

## CONTROLS FOR TRAVELLING

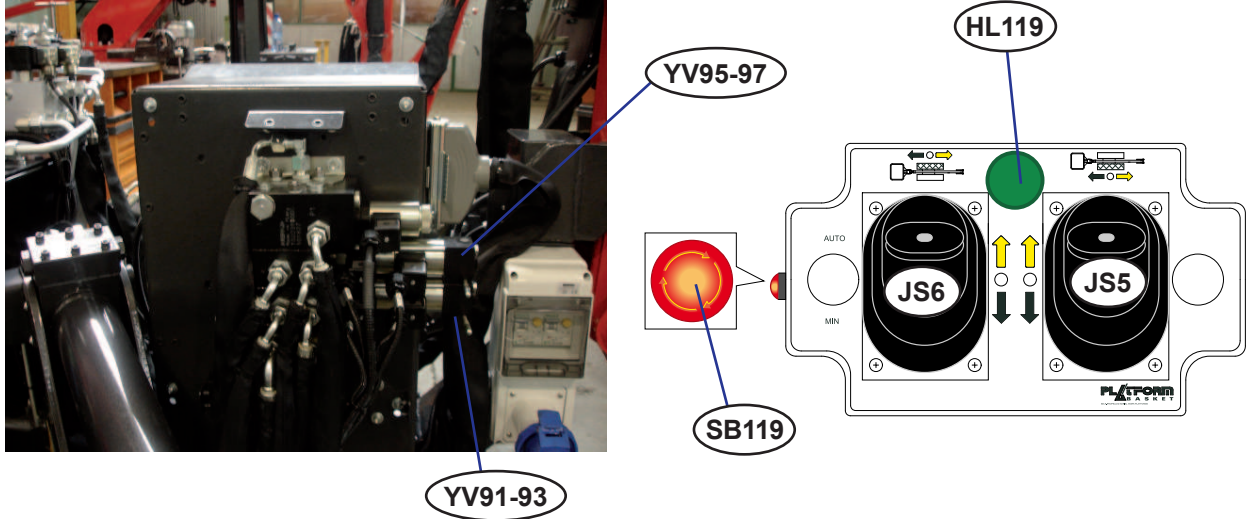

### NOTE

*These controls are enabled ONLY with the aerial part retracted.*

#### JS6 Left track movement lever

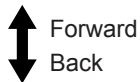

#### JS5 Right track movement lever

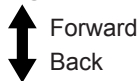

#### SB119 Emergency button - OFF panel

When pressed the wired panel stops immediately.  
To reset button turn it following arrows.

#### HL119 Green indicator light - Pushbutton panel activation/connection

On indicates that panel is working, off that panel is disabled.

#### YV91-93 Left track movement lever

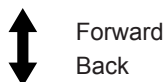

#### YV95-97 Right track movement lever

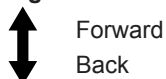

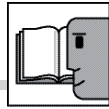

## CONTROLS FOR TRAVELLING

- Verify the right plug of cable between RT connector of the ground panel and to the RNT remote control unit connector.

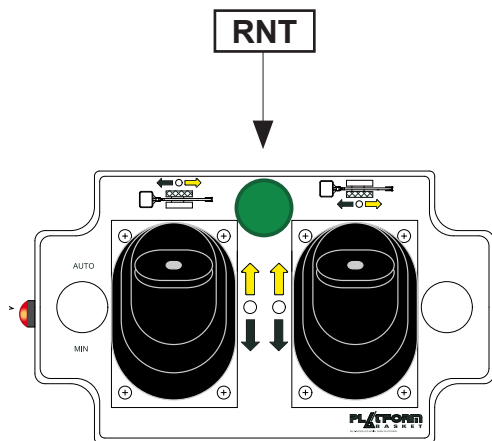

- Move the **SA40** switch (ground control Panel) to “ground station” to work the remote control. The green indicator light on the receiver comes on.
- Enable the pushbutton panel by releasing the emergency button (**SB119**).
- The **HL119** light comes on.

To switch off the pushbutton panel, it is necessary to press the emergency button (**SB119**).

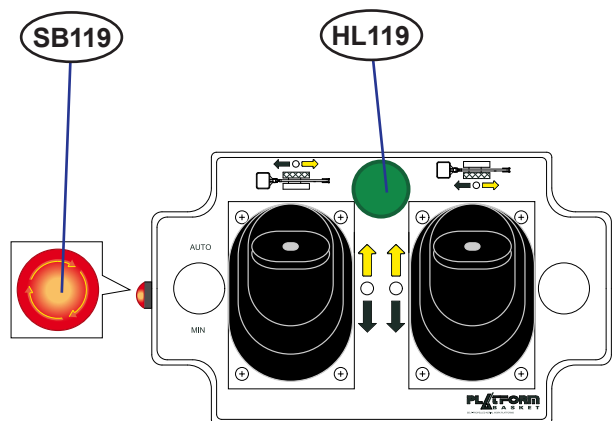
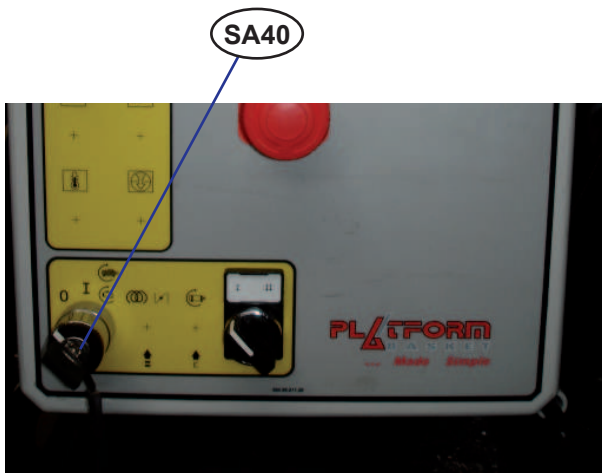

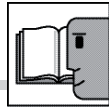

## CONTROLS FOR TRAVELLING



### ATTENTION

Carry out translation operations with the machine's aerial part obligatorily closed (antenna closed, extension in and arm lowered; the arm can only be raised if slope is exceeded).

- Start the engine.
- Move the switch (**SA40**) to "ground position".

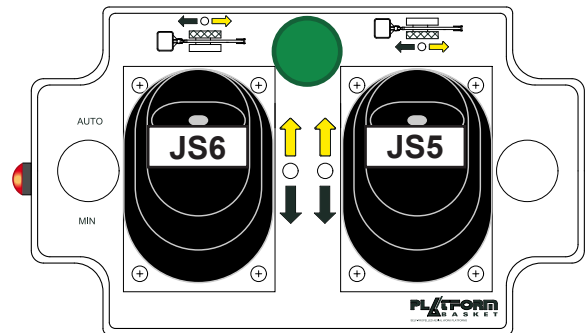
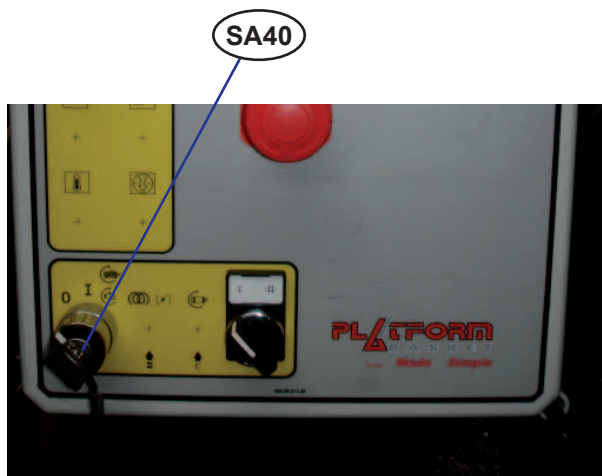

- Proceed with closing the stabiliser feet.
- Move at least 1 metre away from the machine.
- Work the **JS5** and **JS6** panel levers to control forward or backward translation movements.

Each track can be moved individually.

The speed and the direction of movement are proportional to the movement attributed to the levers.

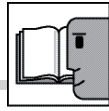

## CONTROLS FOR TRAVELLING

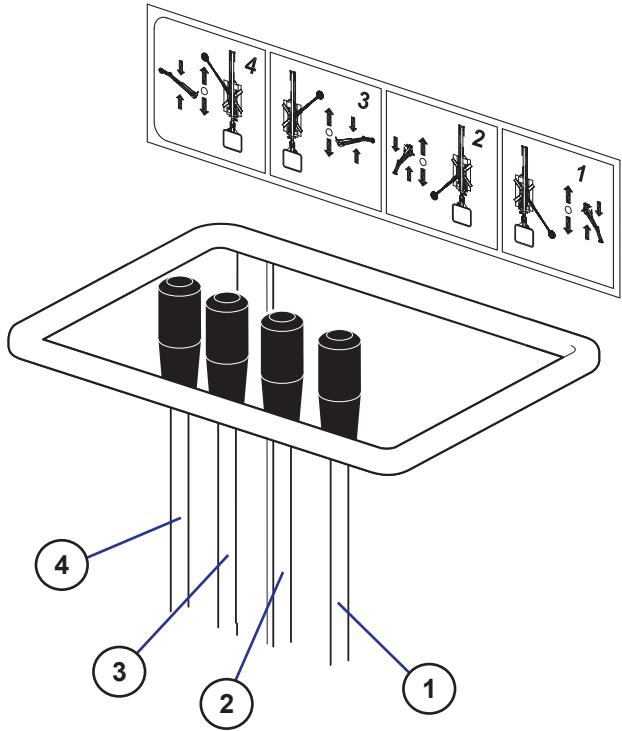
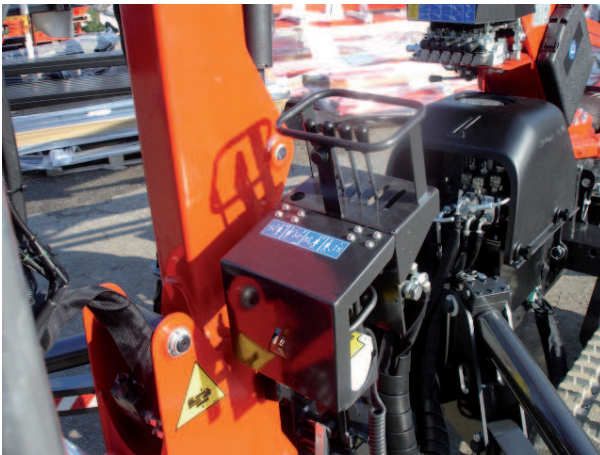

### NOTE

*These controls are enabled ONLY with the aerial part retracted.*

#### 1 Stabiliser N°1 movement

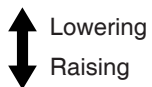

#### 2 Stabiliser N°2 movement

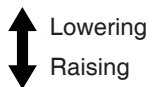

#### 3 Stabiliser N°3 movement

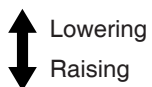

#### 4 Stabiliser N°4 movement

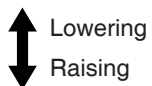

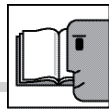

## CONTROLS FOR TRAVELLING

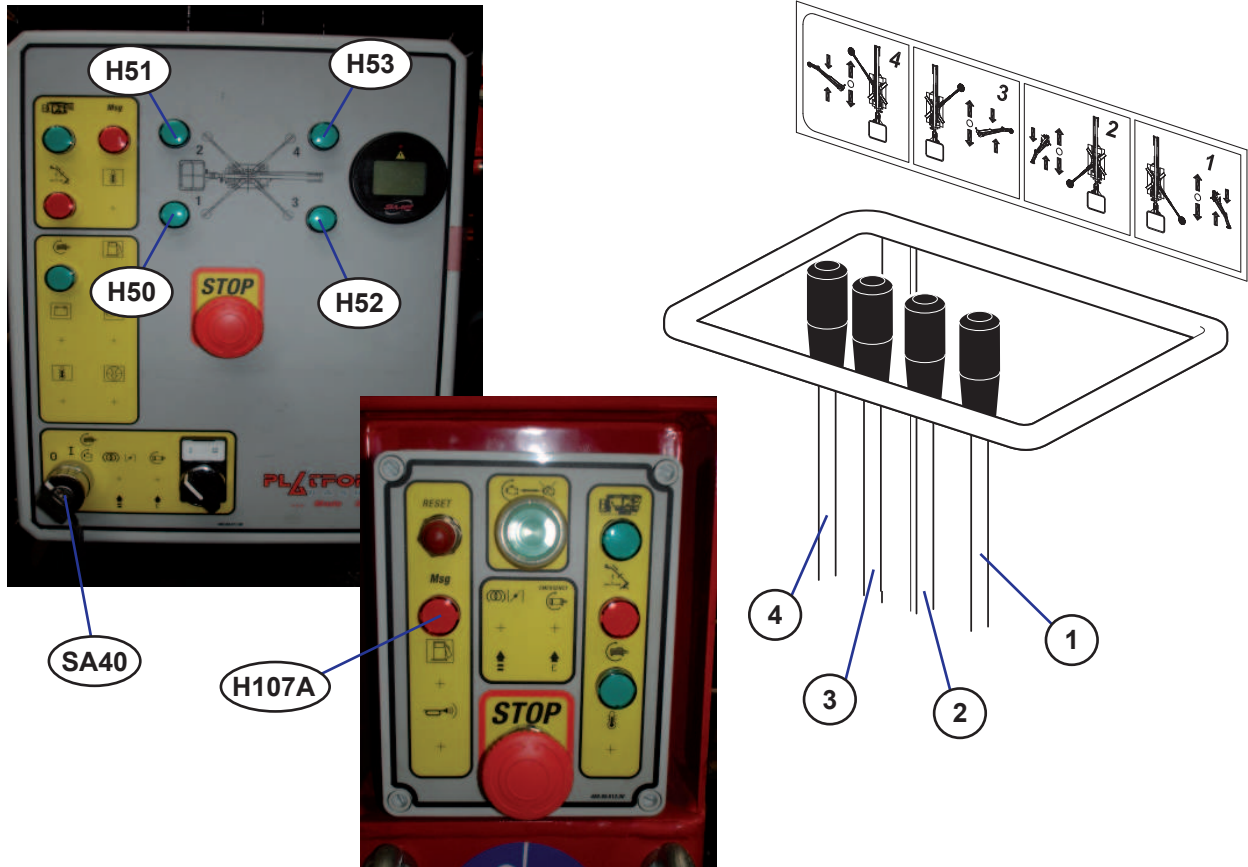

- Start the engine.
- Verify the longitudinal alignment between platform booms and chassis.
- Turn the switch **SA40** to “ground position”.
- operate the stabilization control valve acting the levers pos. 1-2 at the same time until the legs are down to the ground and the relevant lamps H50-H51 are both switched ON. Same operation with levers 3-4 to move the legs down and switch the H52 and H53 lamps ON.

### Note

**The numbers reported aside of the control valve levers match with the sticker numbers applied on each leg.**

The correct stabilization shall be done by checking the sight bubble level indicator position having care of positioning the machine in the most horizontal position and all lamps H50-H51-H52-H53 all ON.

The platform is equipped with an electronic planarity sensor.

Whenever the platform is not leveled within 1 deg of planarity, the acoustic alarm and the H107A lamp fitted to the basket control, box will be activated.

In case of one of the lamps (H50-H51-H52-H53) is OFF , operate the stabilizers control levers up to the complete contact with the ground of each stabilizer and up to the switching ON of all the lamps.

Once the chassis planarity is within 1 deg of inclination and all four lamps on ground panel are ON, the stabilization is OK and the platform booms can be deployed.

It is recommended to lift the platform tracks/crawlers at least 10 cm from ground.

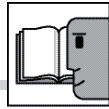

# EB04

## EMERGENCY MANOEUVRE

Situation where there is fault with the main electrical system and it is impossible to start up the pumps/  
main engines

- Turn the selector (SA40) to "ground controls".

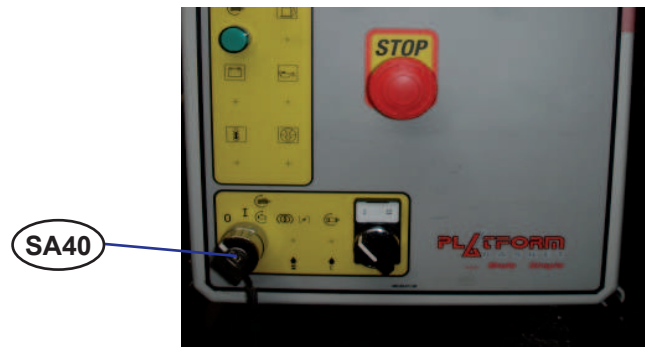

- Remove the plastic carter over the area D.

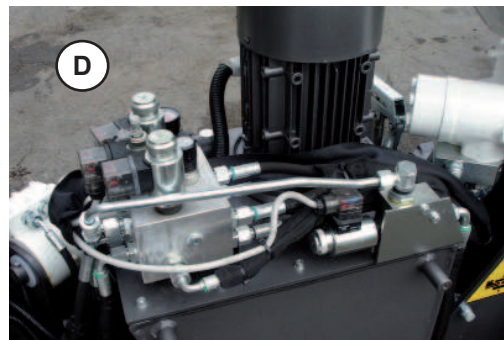
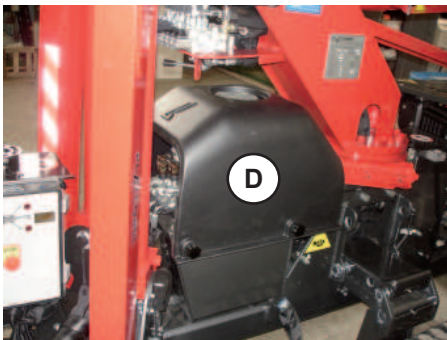

To bypass the valve (YV83):

- Press and turn the pin clockwise to keep it in a lowered, blocked position.

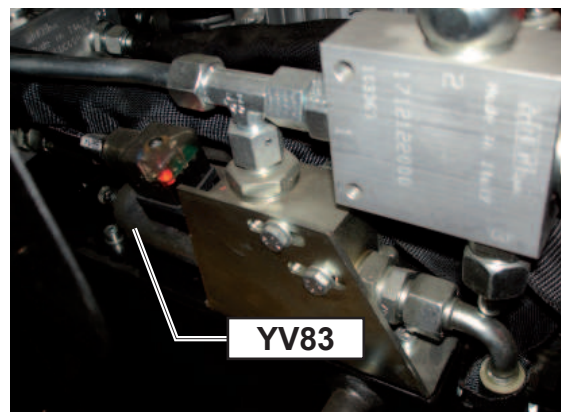
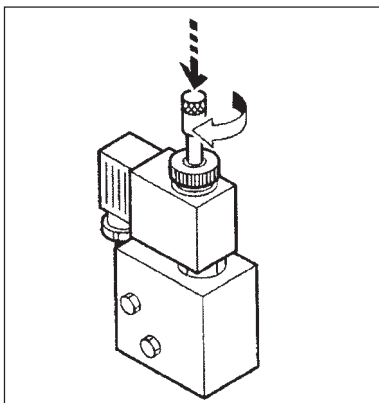

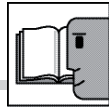

## EMERGENCY MANOEUVRE

- Press **YV82** and keep pressed.

- Move the stabilisers from the carriage distributor using the manual pump (**B**) or, if present and operational, the emergency electric pump 12 V **SB76A**.



**SB76A**

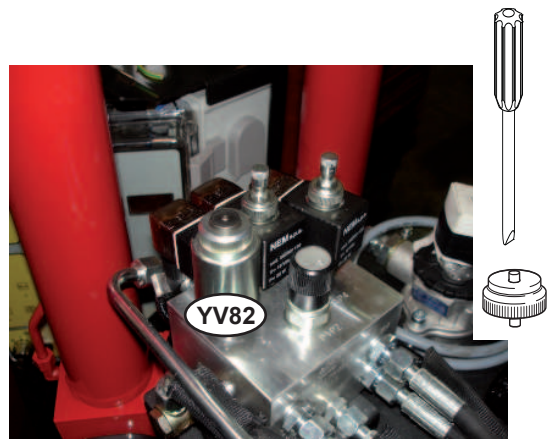

**YV82**

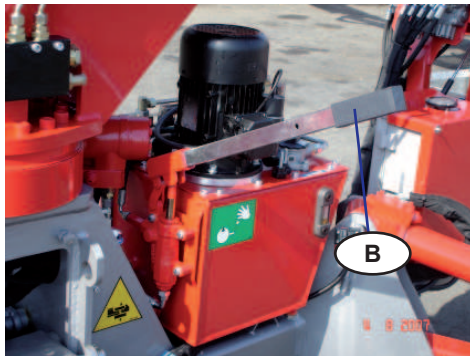

**B**

By keeping the **YV82** valve pressed you can slowly translate manoeuvring the tracks with the emergency distributor lever.



### ATTENTION

*Using the machine in an emergency in conditions the machine has no safety devices controlling range limitation therefore, before reusing the machine, it is obligatory to contact an authorised service centre for any repairs necessary and to replace all the safety devices and place seals on any solenoid valves which have been tampered with.*

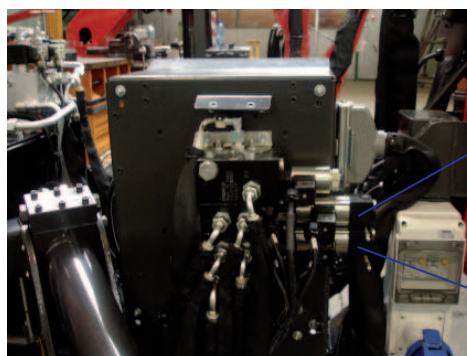

---

SECTION

**F**

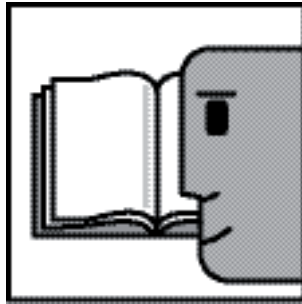

OPTION



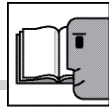

## TEMPERATURE SENSOR

Under the main control panel is positioned the temperature sensor that monitors the ambient temperature.

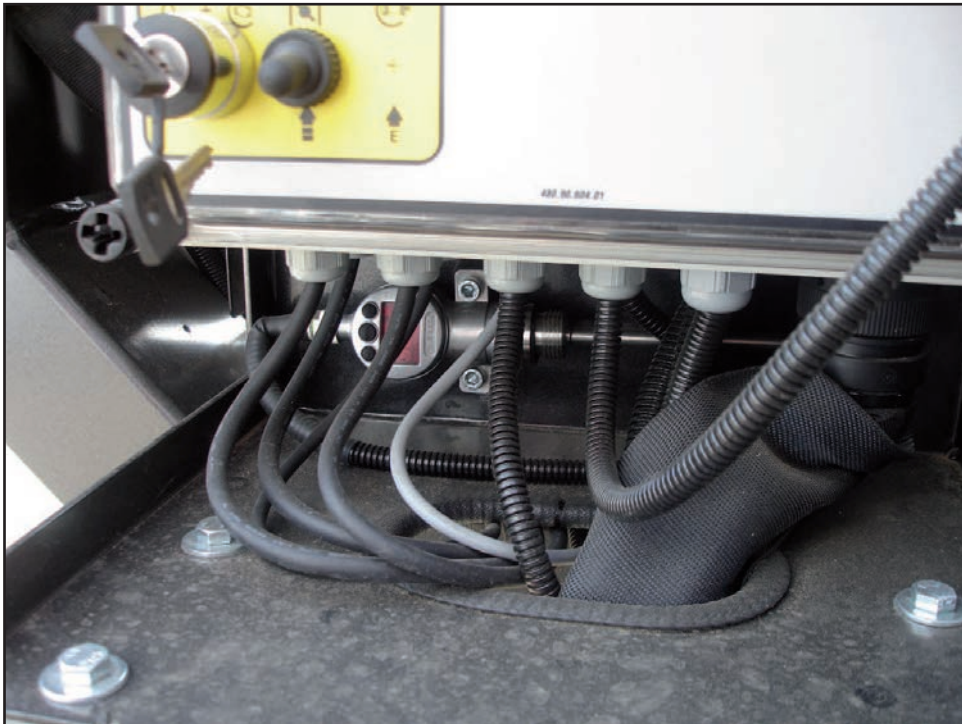

The temperature sensor is set with two steps:

- when the temperature reaches  $-15^{\circ}$  C (the temperature is displayed on the sensor), the operator is notified by a intermittently acoustic signal. The operator must close the machine and can no longer work until the temperature returns above  $-15^{\circ}$  C.
- when the temperature reaches  $-20^{\circ}$  C (the temperature is displayed on the sensor), the machine stops. In this case you can only use stabilizers and tracks. The machine must be closed following the procedure of emergency operations and can not be used until the temperature returns above  $-15^{\circ}$  C.

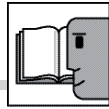

## BASKET WITH LOAD CELL

The basket is provided with a load cell which blocks movement of the machine when the weight inside the basket exceeds 200 kg with a +10% tolerance.

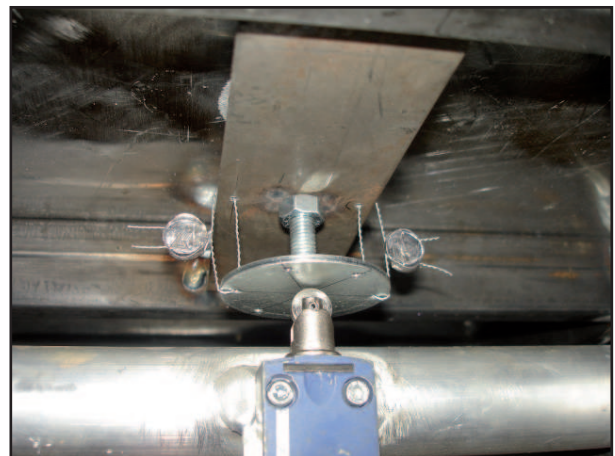
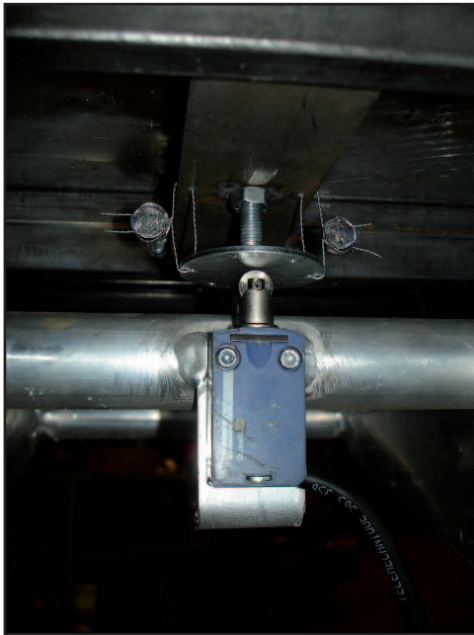

If the basket load limiting device trips, it blocks all movements of the machine. To resume normal operation, the excess load must be eliminated from the basket.

The load detection system is sealed with lead by the manufacturer after having set the micro switch.

**It is strictly forbidden to tamper with the leads.**

**The platform CANNOT be used if the load cell has been tampered with and/or does not work.**

**If the cell is faulty and/or if the leads have been tampered with, contact an authorised assistance centre for repairs.**

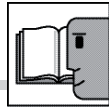

# F03

## HORN

A horn has been placed near the oil tank which the operator uses to warn that the machine is moving, by pressing the specific button (SB39) on the control board of the basket.



SB39

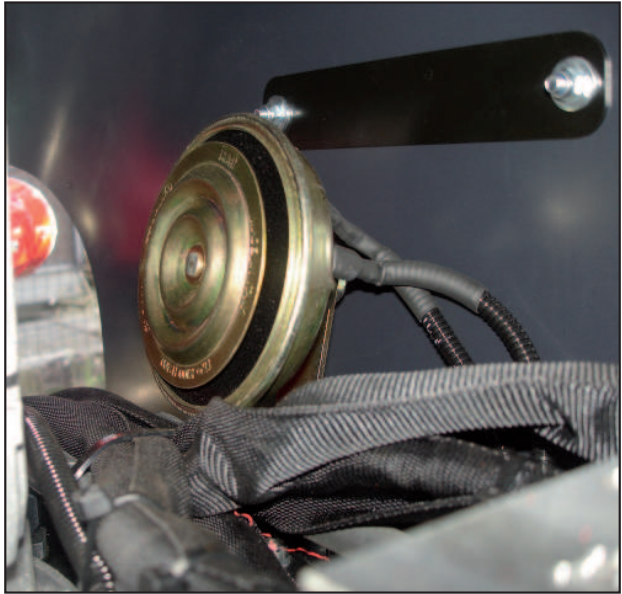



## ORIGINAL DECLARATION OF CONFORMITY

The Legal person charged with the constitution of the Technical Dossier is the Technical Dept. of the PLATFORM BASKET SRL Company with seat in 42028 POVIGLIO (Reggio Emilia), Italy, Via Grande, 27, Manufacturer Company of the Machine.

The undersigned Simona Iraci Tobbi born in Reggio Emilia on 31.07.1982 and living in Cadelbosco Sopra (Reggio Emilia) Via Panini n.15 , President of the board of directors of PLATFORM BASKET Srl with head offices in POVIGLIO (REGGIO EMILIA) Via Grande 27, manufacturer of the following Machine:

### **MAN LIFTING DEVICE WITH RISK OF VERTICAL FALLS GREATER THAN 3 M. (Attachment IV point 17 – Directive 2006/42/CE).**

Description : AWP Aerial Working Platform  
Commercial name of the machine: SPIDER 18.90 PRO  
Serial no. : ----- Manufacturing Year: -----  
Expected use: - LIFTING PERSONS  
- MOBILE, LIFTING WORK PLATFORM

declares, under his own personal responsibility, that it complies with:

- CEE Rules: 2006/42/CE ; 2004/108/CE ; 2000/14/CE
- and to the rules : EN280 :2001+A2 :2009 ; EN 12100-1:2003 ; EN 12100-2 :2003 ; EN 60204-1 :2006

and that, in compliance with attachment IV of the Directive, each and every part of the machine has undergone the above EC-type examination performed by:

**VERICERT srl - Certificazioni e Verifiche – Organismo Notificato No. 1878  
with head office in Via Cavina, 19 – 48100 RAVENNA – ITALY -  
which has issued the EC-TYPE EXAMINATION CERTIFICATE:  
1878M170288CT1111 of 14/11/2011**

- Anyhow the machine is equally corresponding to the dispositions of the directives 2000/14/CE receipt from the decree No 262 of 04/09/2002

Type of machine: aerial working access platform with engine with internal combustion according to the definition n.1 of the enclosure I Art. 13 Dir.2000/14/CE.

Applied procedure for the conformity evaluation: Enclosure V of the Dir. 2000/14/CE

Net power fitted 8.2 (Kw)

Measured acoustic power level Lwa 102 dB(A) is less of the guaranteed value.

Measured acoustic power level Lwa 104 dB(A) it is the value given by the PLE manufacturer.

Poviglio, xx/yy/xyxy

The present certificate is only valid with the Platform Basket Srl corporate stamp

President of the board of directors of

**PLATFORM**  
BASKET

Simona Iraci Tobbi

The original properly completed declaration of conformity is supplied with the machine.



## ORIGINAL DECLARATION OF CONFORMITY

The Legal person charged with the constitution of the Technical Dossier is the Technical Dept. of the PLATFORM BASKET SRL Company with seat in 42028 POVIGLIO (Reggio Emilia), Italy, Via Grande, 27, Manufacturer Company of the Machine.

The undersigned Simona Iraci Tobbi born in Reggio Emilia on 31.07.1982 and living in Cadelbosco Sopra (Reggio Emilia) Via Panini n.15, President of the board of directors of PLATFORM BASKET Srl with head offices in POVIGLIO (REGGIO EMILIA) Via Grande 27, manufacturer of the following Machine:

### **MAN LIFTING DEVICE WITH RISK OF VERTICAL FALLS GREATER THAN 3 M. (Attachment IV point 17 – Directive 2006/42/CE).**

Description : AWP Aerial Working Platform  
Commercial name of the machine: SPIDER 18.90 PRO  
Serial no. : ----- Manufacturing Year: -----  
Expected use: - LIFTING PERSONS  
- MOBILE, LIFTING WORK PLATFORM

declares, under his own personal responsibility, that it complies with:

- CEE Rules: 2006/42/CE ; 2004/108/CE ; 2000/14/CE
- and to the rules : EN280 :2001+A2 :2009 ; EN 12100-1:2003 ; EN 12100-2 :2003 ; EN 60204-1 :2006

and that, in compliance with attachment IV of the Directive, each and every part of the machine has undergone the above EC-type examination performed by:

**VERICERT srl - Certificazioni e Verifiche – Organismo Notificato No. 1878  
with head office in Via Cavina, 19 – 48100 RAVENNA – ITALY -  
which has issued the EC-TYPE EXAMINATION CERTIFICATE:  
1878M170288CT1111 of 14/11/2011**

- Anyhow the machine is equally corresponding to the dispositions of the directives 2000/14/CE receipt from the decree No 262 of 04/09/2002

Type of machine: aerial working access platform with engine with internal combustion according to the definition n.1 of the enclosure I Art. 13 Dir.2000/14/CE.

Applied procedure for the conformity evaluation: Enclosure V of the Dir. 2000/14/CE

Net power fitted 9,9 (Kw)

Measured acoustic power level Lwa 102 dB(A) is less of the guaranteed value.

Measured acoustic power level Lwa 104 dB(A) it is the value given by the PLE manufacturer.

Poviglio, xx/yy/xyxy

The present certificate is only valid with the Platform Basket Srl corporate stamp

President of the board of directors of

**PL/TFORM**  
**B A S K E T**

Simona Iraci Tobbi

The original properly completed declaration of conformity is supplied with the machine.



## ORIGINAL DECLARATION OF CONFORMITY

The Legal person charged with the constitution of the Technical Dossier is the Technical Dept. of the PLATFORM BASKET SRL Company with seat in 42028 POVIGLIO (Reggio Emilia), Italy, Via Grande, 27, Manufacturer Company of the Machine.

The undersigned Simona Iraci Tobbi born in Reggio Emilia on 31.07.1982 and living in Cadelbosco Sopra (Reggio Emilia) Via Panini n.15, President of the board of directors of PLATFORM BASKET Srl with head offices in POVIGLIO (REGGIO EMILIA) Via Grande 27, manufacturer of the following Machine:

### **MAN LIFTING DEVICE WITH RISK OF VERTICAL FALLS GREATER THAN 3 M. (Attachment IV point 17 – Directive 2006/42/CE).**

Description : AWP Aerial Working Platform  
Commercial name of the machine: SPIDER 18.90 PRO  
Serial no. : ----- Manufacturing Year: -----  
Expected use: - LIFTING PERSONS  
- MOBILE, LIFTING WORK PLATFORM

declares, under his own personal responsibility, that it complies with:

- CEE Rules: 2006/42/CE ; 2004/108/CE ; 2000/14/CE
- and to the rules : EN280 :2001+A2 :2009 ; EN 12100-1:2003 ; EN 12100-2 :2003 ; EN 60204-1 :2006

and that, in compliance with attachment IV of the Directive, each and every part of the machine has undergone the above EC-type examination performed by:

**VERICERT srl - Certificazioni e Verifiche – Organismo Notificato No. 1878  
with head office in Via Cavina, 19 – 48100 RAVENNA – ITALY -  
which has issued the EC-TYPE EXAMINATION CERTIFICATE:  
1878M170288CT1111 of 14/11/2011**

- Anyhow the machine is equally corresponding to the dispositions of the directives 2000/14/CE receipt from the decree No 262 of 04/09/2002

Type of machine: aerial working access platform with engine with internal combustion according to the definition n.1 of the enclosure I Art. 13 Dir.2000/14/CE.

Applied procedure for the conformity evaluation: Enclosure V of the Dir. 2000/14/CE

Net power fitted 7,4 (Kw)

Measured acoustic power level Lwa 104 dB(A) is less of the guaranteed value.

Measured acoustic power level Lwa 107 dB(A) it is the value given by the PLE manufacturer.

Poviglio, xx/yy/xyxy

The present certificate is only valid with the Platform Basket Srl corporate stamp

President of the board of directors of

**PLATFORM BASKET**

Simona Iraci Tobbi

The original properly completed declaration of conformity is supplied with the machine.